



CIPM MRA
Comparison reports

CCQM-K82.2023

Methane in air

KEY COMPARISON

© 2026, E. Flores *et al*

This report is published by the BIPM.

Original content from this Report may be used under the terms of the [Creative Commons Attribution 4.0 International \(CC BY 4.0\) Licence](https://creativecommons.org/licenses/by/4.0/).

Any further distribution of this Report must be cited as:
E. Flores *et al* 2026 CIPM MRA Comparison reports 08014

<https://doi.org/10.59161/PDZG9945>

The CIPM MRA Comparison reports are made available under the Creative Commons Attribution International licence:

Attribution 4.0 International (CC BY 4.0)



By using this Report, you accept to be bound by the terms of this licence

(<https://creativecommons.org/licenses/by/4.0/>).

Distribution – you may distribute the Report according to the stipulations below.

Attribution – you must cite the Report.

Adaptations – you must cite the original Report, identify changes to the original and add the following text: This is an adaptation of an original Report by the Author(s). The opinions expressed and arguments employed in this adaptation should not be reported as representing the views of the Authors.

Translations – you must cite the original Report, identify changes to the original and add the following text: In the event of any discrepancy between the original work and the translation, only the text of the original Report should be considered valid.

Third-party material – the licence does not apply to third-party material in the Report. If using such material, you are responsible for obtaining permission from the third-party and of any claims of infringement.

International comparison CCQM-K82.2023: Methane in Air at Ambient level (1800-2200) nmol mol⁻¹

Edgar Flores^{*1}, Joële Viallon¹, Philippe Moussay¹, Tiphaine Choteau¹, Faraz Idrees¹, Robert I. Wielgosz¹, Kiryong Hong², Ji Hwan Kang², Hwan Lee², Janneke van Wijk³, Adriaan van der Veen³, Tanıl Tarhan⁴, Aylin Boztepe⁴, Dilara Kurt⁴, Honghong Wang⁵, Zhe Bi⁵, Christina Cecelski⁶, Jennifer Carney⁶, Christophe Sutour⁷, Mace Tatiana⁷, Fabrice Marioni⁷, Brad Hall⁸, Aimee Hillier⁹, David R. Worton⁹, Paul J. Brewer⁹, Ruth E. Hill-Pearce⁹, Arnuttachai Wongjuk¹⁰, Rairat Sinweeruthai¹⁰, Mphara Mogale¹¹, Kennedy Ramahala¹¹, Tshepiso Mphamo¹¹, Prely Marebane¹¹, Lincon Maluleke¹¹ and Daya Soni¹² and Andrew Crotwell¹³.

¹ Bureau International des Poids et Mesures (BIPM), Pavillon de Breteuil, F-92312 Sèvres Cedex, France.

² Korea Research Institute of Standards and Science (KRISS), 267 Gajeong-ro Yuseong-gu, Daejeon 34113, Republic of Korea.

³ Van Swinden Laboratorium (VSL), Thijsseweg 11 2629 JA Delft The Netherlands.

⁴ National Metrology Institute of Türkiye (UME), Baris Mah. Dr. Zeki Acar Cad. No:1, 41470 Gebze / Kocaeli TÜRKİYE.

⁵ National Institute of Metrology (NIM), China, No.18, Bei-San-Huan Dong Str., Beijing 100013, China.

⁶ National Institute of Standards and Technology (NIST), 100 Bureau Drive, Gaithersburg, MD 20899-8393, USA.

⁷ Laboratoire National de Métrologie et d'Essais (LNE), 1 rue Gaston Boissier 75015 Paris.

⁸ National Oceanic and Atmospheric Administration (NOAA), 325 Broadway, Mail Stop R.GMD1, Boulder, CO 80305 USA.

⁹ National Physical Laboratory (NPL), Hampton Road, Teddington, Middx, TW11 0LW, UK.

¹⁰ National Institute of Metrology of Thailand (NIMT), 3/4-5 Moo 3, Klong 5, Klong Luang, Pathumthani 12120 Thailand.

¹¹ National Metrology Institute of South Africa (NMISA), Building 4W, CSIR Campus, Meiring Naude Road Brummeria 0184.

¹² National Physical Laboratory (NPLI), Dr. K.S. Krishnan Marg, New Delhi – 110012, India.

¹³ Cooperative Institute for Research in Environmental Sciences, University of Colorado Boulder.

Coordinating laboratory:

Bureau International des Poids et Mesures (BIPM)

Study coordinator: Edgar Flores (BIPM)

Correspondence to be addressed to: Edgar Flores edgar.flores@bipm.org
(Tel: + 33 1 45 07 70 92)

Field: Amount of substance

Organizing Body: CCQM

Index

1 Rationale for comparison	4
2 Quantities and Units	4
3 Participants	4
4 Schedule	5
5 Standards prepared by participants	5
5.1 Nominal methane amount fractions	5
5.2 Matrix gas	7
5.3 Information to be submitted with the mixtures	8
6 Measurement facility and procedure	9
6.1 Handling of cylinders	9
6.2 Series of measurements	9
7. Comparison results	9
8 Key Comparison Reference Value	22
8.1 Notation	22
8.2 Degrees of equivalence and graph of equivalence	23
8.3 Youden Plot	27
9 Conclusions	28
10 'How far the light shines' statement	29
ANNEX I- CRDS uncertainty assessment for CCQM –K82.2023 standards	30
Uncertainty of the ratio	30
Intermediate precision	31
Potential biases due to isotope ratio effects, u_{iso}	31
ANNEX II- Application of GC-FID method to CCQM –K82.2023 standards	32
ANNEX III - Measurement reports of participants	41
Van Swinden Laboratorium (VSL)	41
Stability	52
Korea Research Institute of Standards and Science (KRISS)	63

Stability	72
Laboratoire National de Métrologie et d'Essais (LNE)	81
Stability	88
National Institute of Metrology (NIM)	89
Stability	95
National Institute of Metrology of Thailand (NIMT)	96
Stability	106
National Institute of Standards and Technology (NIST)	107
Stability	119
National Metrology Institute of South Africa (NMISA)	135
Stability	141
National Metrology Institute of Türkiye (UME)	147
Stability	152
National Oceanic and Atmospheric Administration (NOAA)	153
Stability	160
National Physical Laboratory (NPL)	161
Stability	168
National Physical Laboratory (NPLI)	169
Stability	180
Bibliography	192

1 Rationale for comparison

The CCQM-K82.2023 comparison was designed to evaluate the level of compatibility of methane in air primary reference mixtures within the range of (1800-2200) nmol mol⁻¹. The balance gas for the standards was either scrubbed dry real air or synthetic air. This comparison also serves to demonstrate the purity analysis capabilities of NMIs (national metrology institutes) for measurements of trace levels of methane in various matrix gases.

The key comparison involved a simultaneous comparison of a suite of 22 primary gas standards, with two travelling standards prepared by each of the 11 participating laboratories. The standards were sent to the BIPM, where the comparison measurements were conducted. The reference value for a given travelling standard was calculated from a calibration line derived from a self-consistent subset of the standards. Measurements at the BIPM were performed using two independent analytical methods: cavity ring-down spectroscopy (CRDS) and gas chromatography with a flame ionisation detector (GC-FID). In light of the technical issues encountered with our GC-FID, as outlined in Section ANNEX II- Application of GC-FID method to CCQM-K82.2023 travelling standards, it is proposed to utilize the results from the CRDS method for the calculation of the key comparison reference values of the comparison.

The key comparison CCQM-K82.2023 is considered to present an analytical challenge and is therefore classified as a Track C comparison in the CCQM nomenclature.

2 Quantities and Units

In this comparison the measurand was the amount of substance fraction of methane in either synthetic, scrubbed, or natural air¹, with measurement results being expressed in mol mol⁻¹ and its submultiples $\mu\text{mol mol}^{-1}$ or nmol mol⁻¹.

3 Participants

The comparison included 11 participants listed below:

- Korea Research Institute of Standards and Science (KRISS)
- Laboratoire National de métrologie et d'Essai (LNE)
- National Institute of Metrology (NIM)
- National Institute of Metrology Thailand (NIMT)

¹ Synthetic air – A gas mixture prepared by mixing of high purity gases, such as oxygen, nitrogen, argon, to replicate the composition of ambient air. The final composition typically mirrors the natural abundances of nitrogen, oxygen, and argon found in the atmosphere air. Scrubbed air – air from a natural source that has been scrubbed for all major analytes, excluding oxygen, nitrogen, and noble gases. An air sample, collected directly from ambient, air that has been scrubbed to remove all major analytes, except for the major components of ambient air, such as oxygen, nitrogen, and noble gases, and pressurized into a gas cylinder for use as a balance gas in the preparation of gas mixtures. These major components are included at their natural abundance levels. Natural air – an air sample that has been pressurized into a gas cylinder from an outdoor source and is being used as the balance gas within that mixture. Based on the preparative process all ambient gases, excluding water, are included at natural abundance levels. An air sample collected directly from ambient air, with water vapor removed during the collection process, and pressurized into a gas cylinder for use as a balance gas in the preparation of gas mixtures or for dissemination. All components of ambient air, except for water vapor, are included at their natural abundance levels.

- National Institute of Standards and Technology (NIST)
- National Metrology Institute of South Africa (NMISA)
- National Oceanic and Atmospheric Administration, Global Monitoring Laboratory (abbreviated as NOAA)
- National Physical Laboratory (NPL)
- National Physical Laboratory of India (NPLI)
- National Metrology Institute of Türkiye (UME)
- Van Swinden Laboratorium, the National Metrology Institute of the Netherlands (VSL)

4 Schedule

The revised schedule for the project was as follows:

May 2023- Oct 2023	Mixtures preparation, verification and stability tests by participants.
July 2023- Dec. 2023	Shipment of cylinders to the BIPM
Jan. 2024 – April 2024	Analysis of mixtures by the BIPM
May 2024 –June 2024	Shipment of cylinders back from the BIPM to participants
June2024 – Sept 2024	2nd set of analysis of mixtures by participants
March 2025	Distribution of Draft A1 report

5 Standards prepared by participants

5.1 Nominal methane amount fractions

Participants were asked to submit two standards prepared using their usual technique, in which the methane amount fraction shall be within a predefined range. The amount fraction intervals were chosen so that the values of methane amount fractions in the first standards would be distributed to span the low (L) range from 1780 nmol mol⁻¹ to 1820 nmol mol⁻¹, while the values in the second standards would span the high (H) range from 2180 nmol mol⁻¹ to 2220 nmol mol⁻¹. Each interval was divided into three sub-intervals of 10 nmol mol⁻¹ width each. After registering for the key comparison, each participant was informed by the BIPM of the specific amount fraction sub-range within which each standard had to be produced. The sub-ranges were identified as L1, L2, L3, H1, H2, and H3, with the amount fractions of these referred to listed in Table 1. The combinations in which participants were asked to provide a standard in both the low and high ranges is listed in Table 2. The pairs of standards to be supplied by participants were confirmed by the BIPM upon registration, based on the order in which completed registrations were received.

Table 1. Sub-range code and corresponding nominal amount fraction.

Sub-range Code	Assigned CH ₄ amount fraction range x_{NMI} (nmol mol ⁻¹)
L1	1780-1790
L2	1795-1805
L3	1810-1820
H1	2180-2190
H2	2195-2205
H3	2210-2220

Table 2. Participants and sub-ranges of pairs of standards as requested.

Participants' registration order	Pair of Standards to be submitted by participant
VSL, NIMT	L1 and H1
NIST, NPLI	L1 and H2
NPL, KRISS	L2 and H1
UME	L2 and H3
NOAA, NIM	L3 and H2
LNE, NMISA	L3 and H3

5.2 Matrix gas

Based on the potential biases that could have been introduced into the spectroscopic comparison method (CRDS) due to variations in the composition of the air matrix across different standards, participating laboratories were required to ensure that the composition of their air matrix was consistent with the nominal amount fractions within real air, as stated above, within the following limits:

Table 3. Limits for balance gas composition in standards submitted for the comparison. Based upon the possible biases that could be introduced into the spectroscopic comparison method (CRDS) due to variation in the composition of the air matrix in different standards, participating laboratories were asked to ensure that the composition of their air matrix was within these limits.

Component in Air	Minimum amount fraction permitted within submitted mixture	Maximum amount fraction permitted within submitted mixture
Nitrogen	0.77849 mol mol ⁻¹	0.78317 mol mol ⁻¹
Oxygen	0.20776 mol mol ⁻¹	0.21111 mol mol ⁻¹
Argon	8.865 mmol mol ⁻¹	9.799 mmol mol ⁻¹
Carbon Dioxide	0 μmol mol ⁻¹	500 μmol mol ⁻¹

According to the results submitted by participants (see Table 4):

- All mixtures, except those from NOAA, were produced in synthetic air.
- All mixtures complied with the specified requirements, except for VSL174373, which showed a slight exceedance of the oxygen limit. However, as reported by Nara et al.¹, this level of oxygen deviation has a negligible influence on the CRDS response and the resulting regression analysis, and was therefore not expected to affect the overall conclusions of this study.
- The methane amount fraction was reported above the limit of their range in two mixtures: by 0.75 nmol mol⁻¹ in cylinder KRISS-D133520 and by 14 nmol mol⁻¹ in cylinder KRISS-D133707.
- The methane amount fraction was reported below the limit of their range in two mixtures: by 6.4 nmol mol⁻¹ in cylinder NPL-D133091 and by 0.5 nmol mol⁻¹ in cylinder UME-PSM034418.

A sensitivity analysis was conducted to assess the influence of these out-of-range values on the regression. Their inclusion had no impact whatsoever on the final regression results. Furthermore, the cylinders remained well distributed across the low and high concentration ranges, supporting the robustness of the regression performed using all standards (see Assigned Values Table 6).

5.3 Information to be submitted with the mixtures

When the travelling standards were submitted, participants were required to complete and submit the results form to the BIPM, specifying the methane amount fraction value and the associated uncertainty for each standard submitted. Additionally, participants were to complete an information sheet for each submitted standard, providing at least the mandatory information outlined below.

Mandatory information to be provided included:

- a) a purity table with uncertainties for the nominally pure N₂, O₂, Ar or scrubbed Air and CO₂ parent/balance gases
- b) a description of the metrological traceability and measurement method for the measurement of the amount fraction trace methane (critical impurity) in the pure parent/balance gases;
- c) a purity table for each of the final mixtures including the value and uncertainty of the methane amount fraction which arises from the sum of trace methane that is a critical impurity in the pure parent/balance gases;
- d) an uncertainty budget for the final mixtures including gravimetric, stability, verification components and final combined uncertainty

Optional information that would be useful to provide was:

- e) a brief outline of the dilution series undertaken to produce the final mixtures;
- f) a purity table with uncertainties for the nominally pure methane parent gas
- g) a brief outline of the verification procedure applied to the final mixtures;
- h) a brief outline of any stability testing of the mixtures between the time they are prepared and the time they are shipped to the BIPM.

Information submitted by participating laboratories, including stability measurements, is included in ANNEX III - Measurement reports of participants. The final methane amount fractions reported by participants, after stability measurements, are listed in Table 4, where:

x_{NMI} is the value assigned by the participating NMI based on gravimetric preparation;

$u(x_{\text{NMI}})$ is the standard uncertainty including contributions from verification associated with the assigned value x_{NMI} ;

It should be noted that three participants (NIST, NMISA, and NPLI) reported changes in their stated uncertainties after stability measurements with some cases showing significant adjustments.

Figure 1 plots the final CH₄ amount of substance fraction reported by the participants for each gas standard. In this figure the error bars represent the standard uncertainty associated with the certified value plotted separately in Figure 2.

6 Measurement facility and procedure

The comparison facility of the BIPM is composed of two analytical instruments: one CRDS and one GC-FID. It is very similar to the one used in the previous comparison CCQM-K82², with a more recent CRDS instrument (Picarro G2301).

The measurements procedure, briefly described below, was also very similar to the one used in 2013, and validated prior to the 2013 comparison using standards in different matrices provided by NIST³.

6.1 Handling of cylinders

On receipt by the BIPM, all cylinders were allowed to equilibrate at laboratory temperature for at least 24 hours. The pressure inside the cylinders was measured and recorded, and measured again before their return to participant's laboratories (see Table 5). All cylinders were rolled for 1 hour to ensure homogeneity of the mixture. Each cylinder was connected from the pressure reducer to one inlet of a 32-inlet automatic gas sampler. The sampler was connected to two analysers, the GC-FID and to the CRDS. The pressure reducer of each cylinder was flushed nine times with the mixture. The cylinder valve was closed leaving the high pressure side of the pressure reducer at the cylinder pressure and the low pressure side of the pressure reducer at ~300 kPa (abs). The cylinders were left stand at least 24 hours, to allow conditioning of the pressure reducers.

6.2 Series of measurements

The mixtures were analysed using CRDS first, then GC-FID. The CRDS measurements were performed under repeatability conditions over 16 hours, while the GC-FID measurements were conducted over 9 days. In both cases, the BIPM-reported value was based on the drift-corrected ratio between the instrument response and a control cylinder. Two cylinders owned by the BIPM were added at the start and the end of all measurement sequences, to monitor the intermediate precision of the system.

7. Comparison results

Measurements were performed at the BIPM from January to April 2024. Table 5 lists the inlet pressure before and after the standards were analyzed by the BIPM.

The value assignment of each cylinder was performed following the methods outlined in in section 6.2. Due to the GC-FID exhibiting noise levels five times higher than in 2014, affecting repeatability despite consistent results (see section ANNEX II- Application of GC-FID method to CCQM –K82.2023 standards), the CRDS measurements were chosen as the reference values, detailed in Table 6 where:

R is the drift-corrected ratio to the control cylinder of the response obtained by CRDS to each standard;

$u(R)$ is the standard uncertainty of R ;

To simplify the presentation of the results, Table 6 results were plotted in Figure 3, Figure 4, Figure 5 and Figure 6.

Once returned to the participants, the standards were analyzed by the participating laboratories in order to verify the stability of the mixtures.

According to the conclusions of the CCQM-K82 comparison in 2014, a key measurement required for the preparation of accurate methane standards was the determination of trace methane in the balance gas¹. Similarly, in most cases, a major contributor to the reported uncertainty of participants' standards arises from the measurement of trace levels of methane in the balance gas used for preparing their standards. The average trace methane levels in the balance gas of the standards provided and measured by the participants are plotted in this occasion in Figure 7. Notably, the CH₄ background levels are higher on average compared to 2014, with half of the participants reporting at least double the background methane in their synthetic air components compared to a decade ago.

Table 4. Purity table of the submitted gas mixtures according to participants' reports in ANNEX III - Measurement reports of participants. Synthetic Air is identified as S. A. and Purified real air as R. A.* No data given.

Participant	Number of Cylinder	Gas Matrix	NMI's assigned CH ₄ amount fraction	NMI's assigned expanded uncertainty $k=2$	NMI's assigned CO ₂ amount fraction	NMI's assigned Ar amount fraction	NMI's assigned O ₂ amount fraction	NMI's assigned N ₂ amount fraction
			x_{NMI} (nmol mol ⁻¹)	$U(x_{\text{NMI}})$ (nmol mol ⁻¹)	x_{CO_2} (μmol mol ⁻¹)	x_{Ar} (mmol mol ⁻¹)	x_{O_2} (mol mol ⁻¹)	x_{N_2} (mol mol ⁻¹)
KRISS	D133520	S. A.	1805.75	1.37	397.75740	9.56240	0.21049	0.77955
KRISS	D133707	S. A.	2203.12	1.67	370.68890	9.24170	0.21027	0.78011
LNE	APE1126469	S. A.	1814.50	2.60	0.00540	9.32700	0.20959	0.78108
LNE	APE997315	S. A.	2213.10	3.00	0.00540	9.29600	0.20924	0.78146
NIM	L226018046	S. A.	1812.70	1.00	0	9.41470	0.20935	0.78123
NIM	L226014004	S. A.	2202.10	1.20	0	9.29491	0.20963	0.78107
NIMT	D094433	S. A.	1785.08	5.00	370.81869	9.13467	0.21007	0.78042
NIMT	D094436	S. A.	2184.90	5.68	365.45548	9.10020	0.20927	0.78126
NIST	FF68037	S. A.	1786.81	2.24	441.00000	9.38000	0.20949	0.78069
NIST	FF68033	S. A.	2201.68	4.32	441.00000	9.38000	0.20949	0.78069
NMISA	D73 3629	S. A.	1813.00	45.00	254.59000	9.00700	0.21009	0.78064
NMISA	D67 9445	S. A.	2218.00	57.00	473.69000	9.00100	0.21059	0.77993
NOAA	FB04227	R. A.	1813.30	3.40	389.00000	9.30000	0.20960	0.78070
NOAA	FB04226	R. A.	2200.50	4.10	424.00000	9.30000	0.20960	0.78070
NPL	D133091	S. A.	1789.60	1.70	0.03300	9.25820	0.20801	0.78273
NPL	D132886	S. A.	2186.60	2.08	0.03300	9.30020	0.20929	0.78141
NPLI	D001986	S. A.	1787.45	10.17	0	9.34300	0.20832	0.78232
NPLI	D001989	S. A.	2199.66	8.04	0	9.60700	0.20912	0.78127
UME	PSM034418	S. A.	1794.50	3.14	369.75170	9.38155	0.20943	0.78082
UME	PSM034390	S. A.	2216.51	4.30	369.74640	9.31283	0.20852	0.78180
VSL	VSL174000	S. A.	1787.29	3.57	370.74000	9.32450	0.20956	0.78075
VSL	VSL174373	S. A.	2187.86	4.38	373.71000	9.32040	0.21130	0.77900

Table 5. Pressure of the gas standards on arrival and departure from the BIPM.

Cylinder ID	Pressure at cylinders arrival (bar)	Pressure before cylinders departure (bar)	Real gas consumption (bar)
KRISS-D133520	93.0	91.5	1.5
KRISS-D133707	94.0	92.0	2.0
LNE-APE1126469	127.0	123.5	3.5
LNE-APE997315	128.0	125.5	2.5
NIM-L226014004	127.0	125.0	2.0
NIM-L226018046	131	130	1.0
NIMT-D094433	105.0	103	2.0
NIMT-D094436	103.0	101.0	2.0
NIST-FF68033	84.0	80.5	3.5
NIST-FF68037	77.0	74.0	3.0
NMISA-D679445	116.0	114.0	2.0
NMISA-D733629	103.0	98.0	5.0
NOAA-FB04227	130.0	125.5	4.5
NOAA-FB04226	134.0	128.0	6.0
NPL-D132886	107.0	105.0	2.0
NPL-D133091	108.0	106.0	2.0
NPLI-D001986	114.0	112.0	2.0
NPLI-D001989	113.0	111.0	2.0
UME-PSM034418	122.0	116.5	5.5
UME-PSM034390	120.0	80.0	40.0
VSL-D044000	118.0	114.0	4.0
VSL-D044373	118.0	108.0	10.0

Table 6. Cylinders reference, CH₄ amount fraction assigned by the participant x_{NMI} , its standard uncertainty $u(x_{\text{NMI}})$, drift-corrected ratios to the control cylinder of CRDS response to each cylinder R , and its standard uncertainty $u(R)$.

Cylinder reference	x_{NMI} (nmol mol ⁻¹)	$u(x_{\text{NMI}})$ (nmol mol ⁻¹)	R	$u(R)$
KRISS-D133520	1805.75	0.68	0.99518	0.00013
KRISS-D133707	2203.12	0.84	1.21404	0.00014
LNE-APE1126469	1814.50	1.30	0.99903	0.00013
LNE-APE997315	2213.10	1.50	1.21845	0.00014
NIM-L226014004	2202.10	0.60	1.21267	0.00014
NIM-L226018046	1812.70	0.50	0.99819	0.00013
NMISA-D679445	2218.00	28.50	1.20433	0.00014
NMISA-D733629	1813.00	22.50	0.98123	0.00013
NIMT-D094433	1785.08	2.50	0.98139	0.00013
NIMT-D094436	2184.90	2.84	1.20136	0.00014
NIST-FF68033	2201.68	2.16	1.21258	0.00014
NIST-FF68037	1786.81	1.12	0.98505	0.00013
NOAA-FB04226	2200.50	2.05	1.21366	0.00014
NOAA-FB04227	1813.30	1.70	0.99976	0.00013
NPL-D132886	2186.60	1.04	1.20323	0.00014
NPL-D133091	1789.60	0.85	0.98499	0.00013
NPLI-D001986	1787.45	5.09	0.96757	0.00013

Cylinder reference	x_{NMI} (nmol mol ⁻¹)	$u(x_{\text{NMI}})$ (nmol mol ⁻¹)	R	$u(R)$
NPLI-D001989	2199.66	4.02	1.18681	0.00013
UME-PSM034390	2216.51	2.15	1.21672	0.00014
UME-PSM034418	1794.50	1.57	0.98450	0.00013
VSL-D044000	1787.29	1.79	0.98368	0.00013
VSL-D044373	2187.86	2.19	1.20411	0.00014

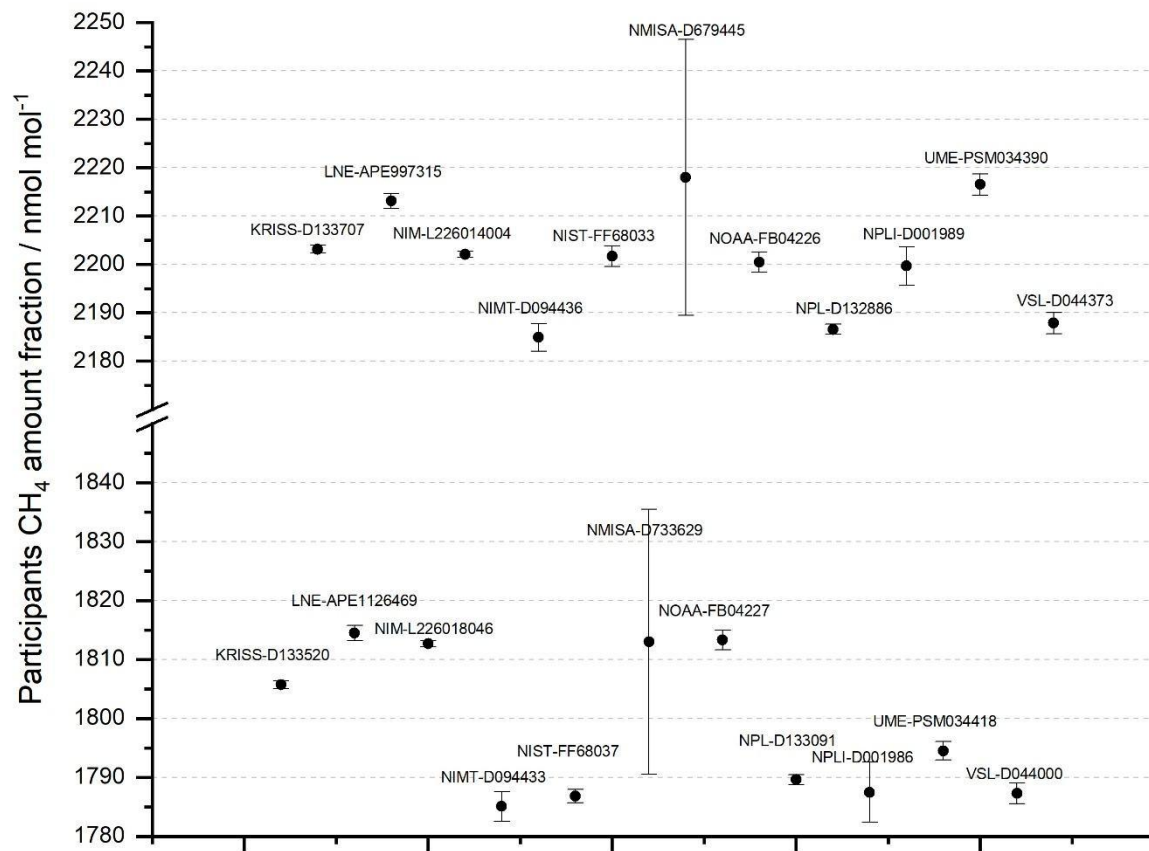

Figure 1. CH₄ amount fractions x_{NMI} provided by participants. The error bars represent the standard uncertainty associated with the submitted values.

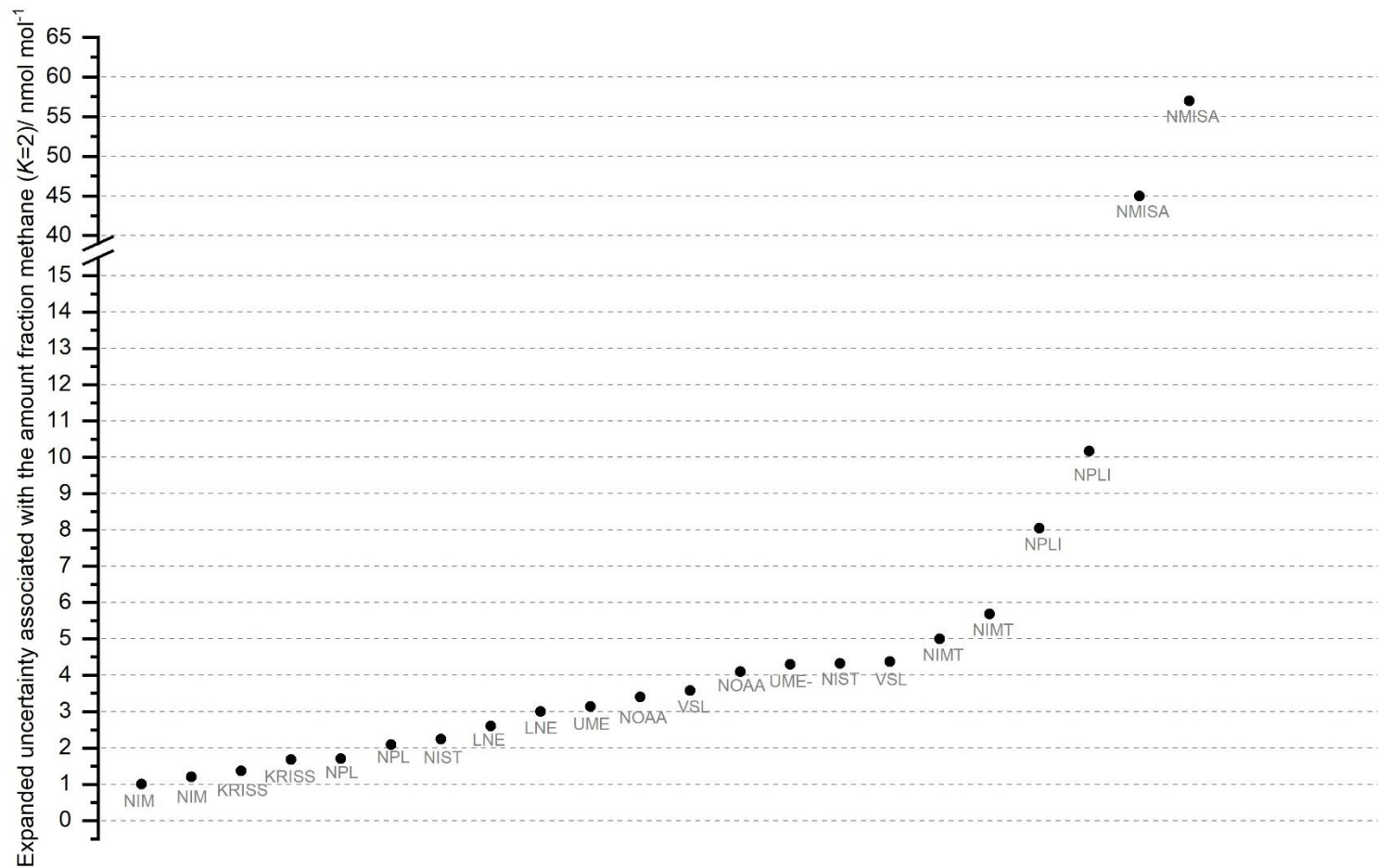

Figure 2. Participants' assigned expanded uncertainties $U(x_{NMI})$ associated with the amount fraction methane.

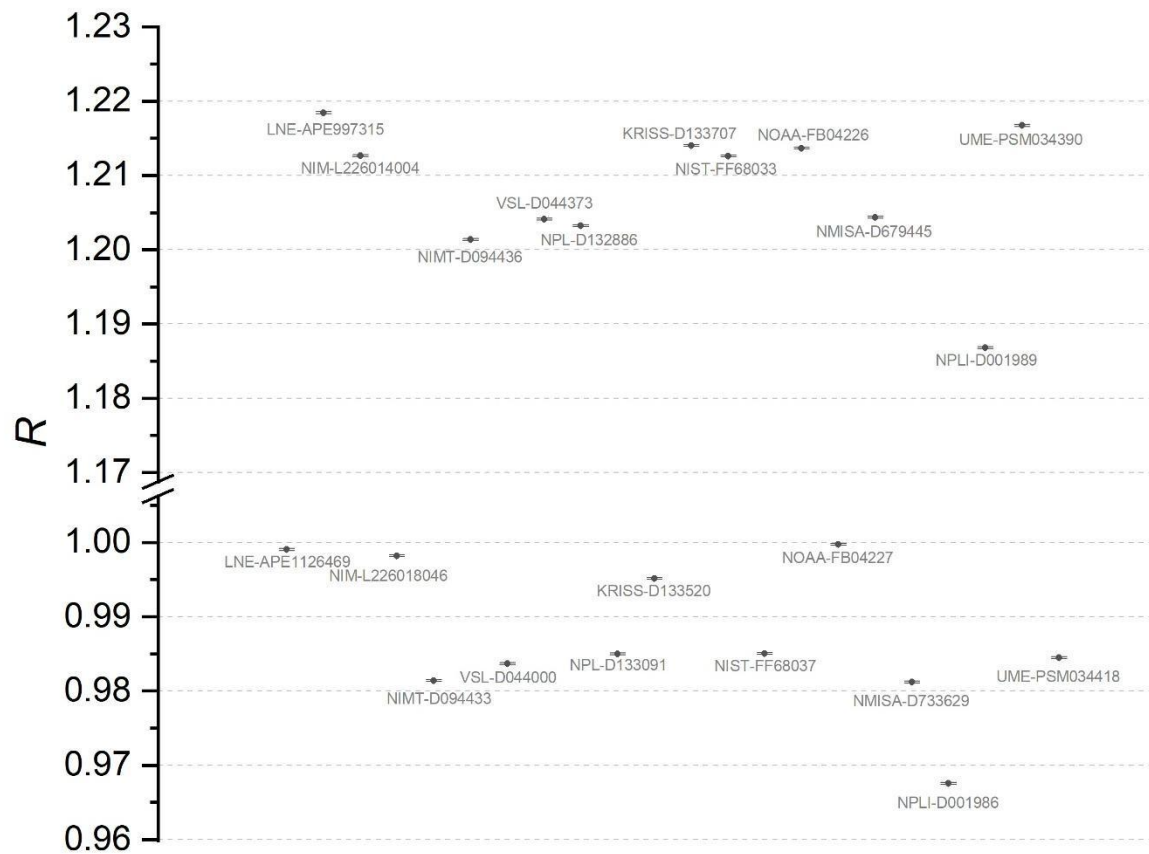

Figure 3. CRDS ratios to the control standard. The error bars represent the standard uncertainty of the BIPM measurement results. For further information see ANNEX II-

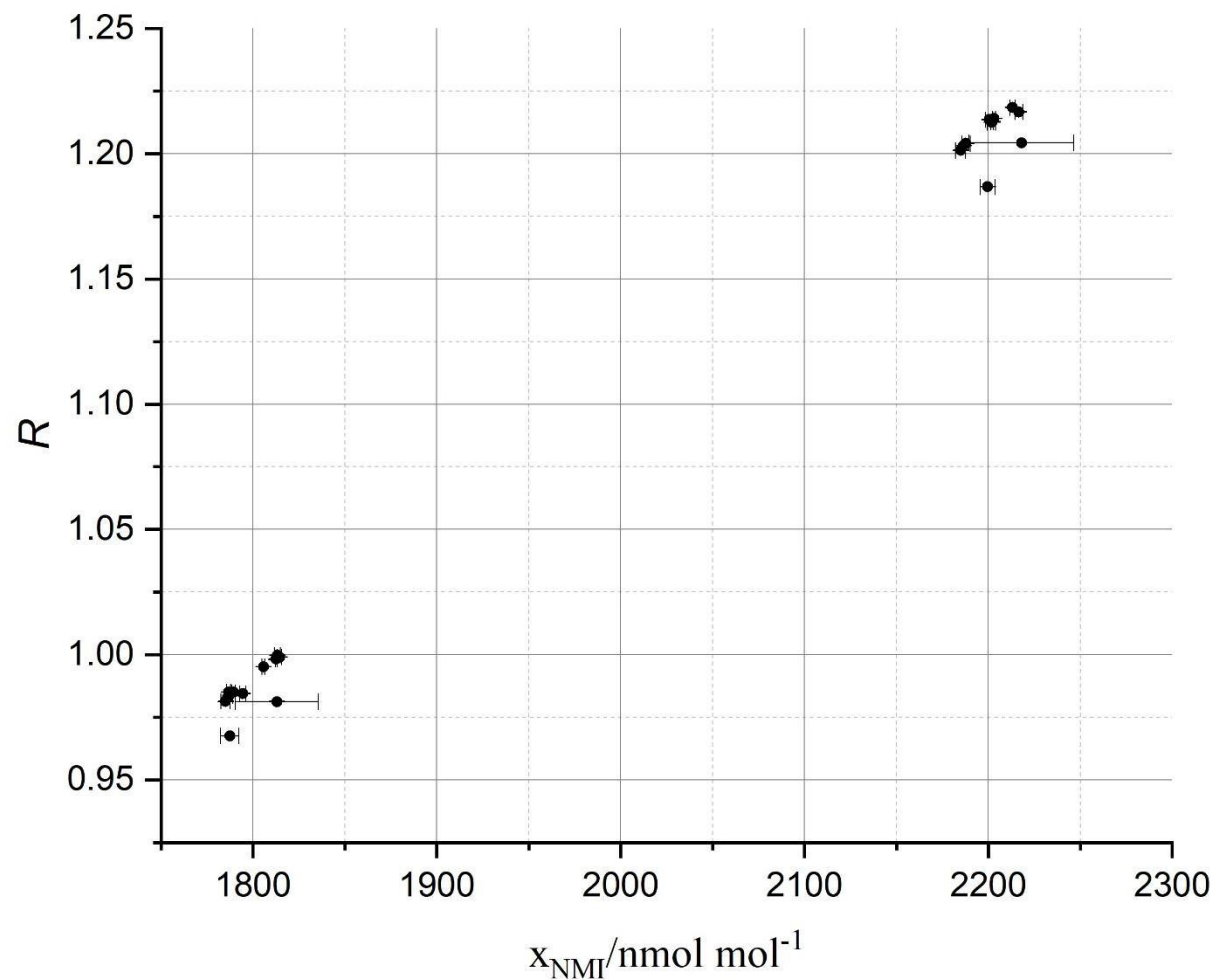

Figure 4. CRDS ratios to control cylinder as a function of the amount fraction methane (x -axis). The error bars represent the standard uncertainty of the BIPM measurement results (y -axis).

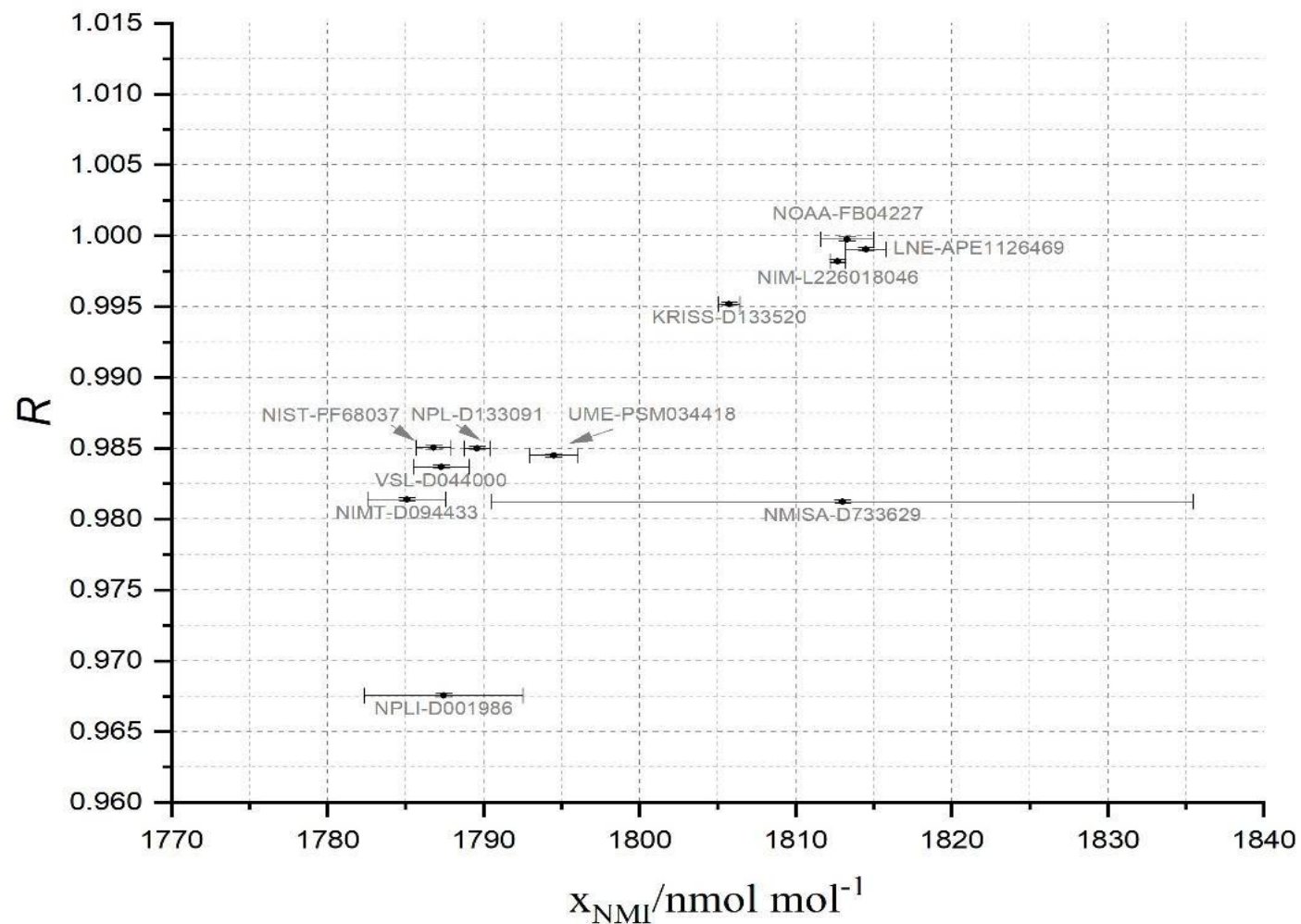

Figure 5. Zoom of the previous figure on the lower range of amount fractions. The error bars represent the standard uncertainty ($k=1$) associated with the BIPM measurement results (y -axis) and the NMI gravimetric values (x -axis).

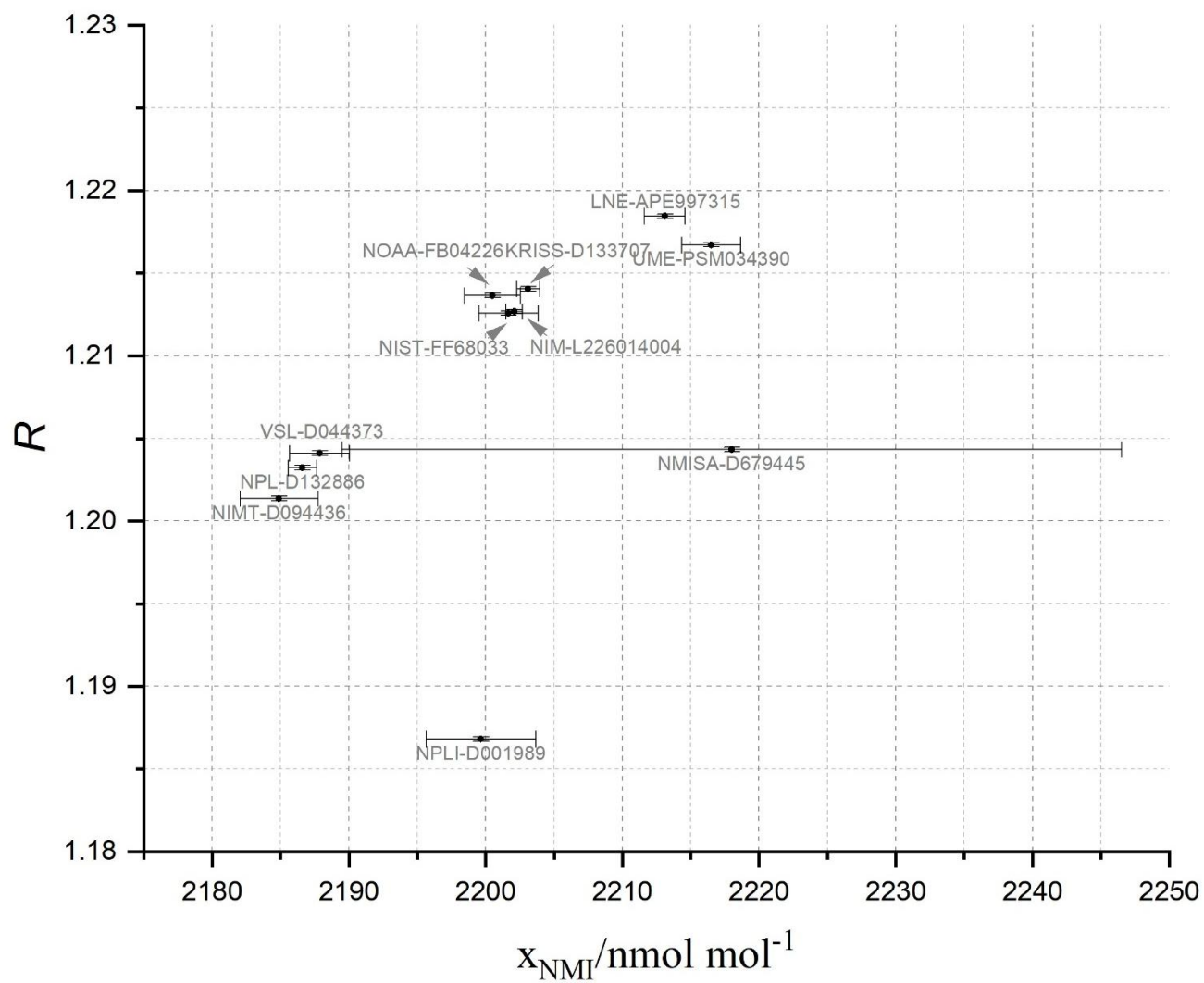
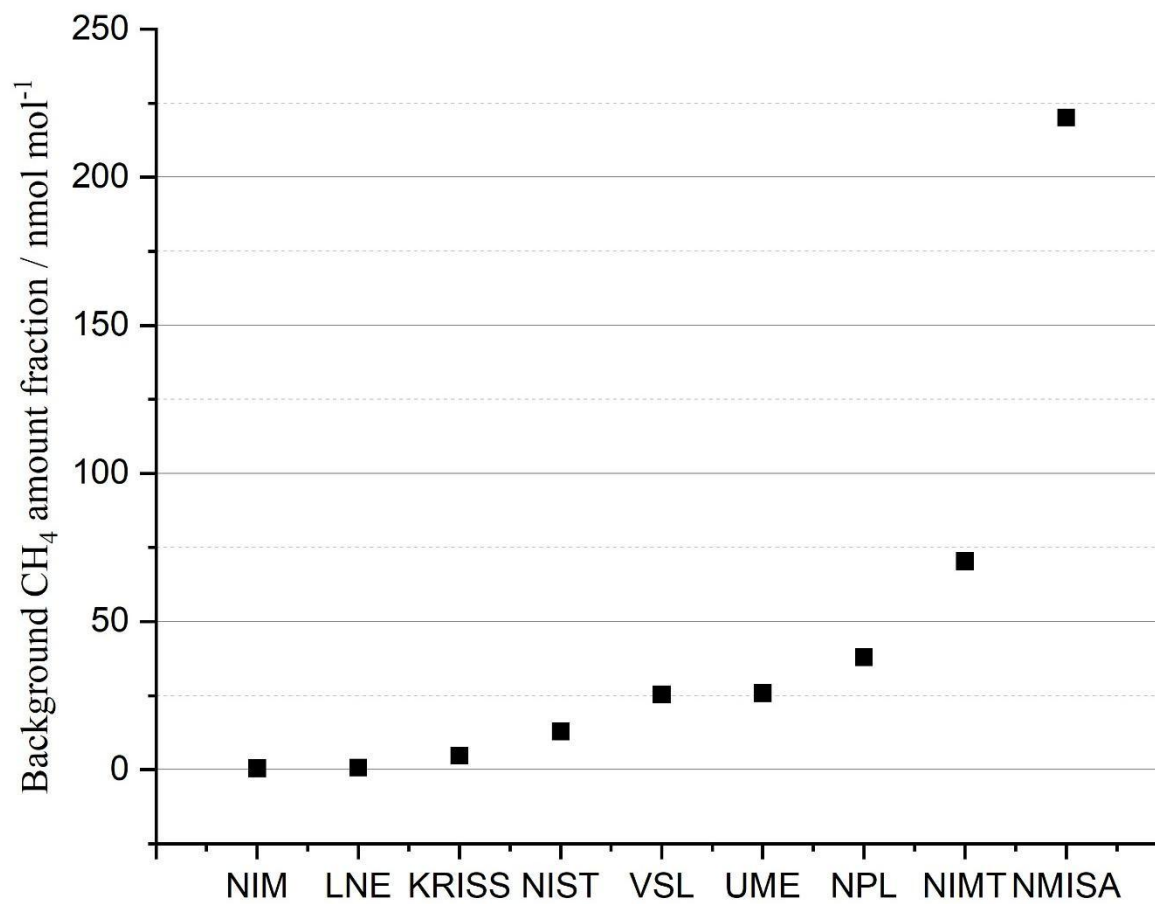

Figure 6. Zoom of the previous figure on the higher range of amount fractions. The error bars represent the standard uncertainty ($k=1$) associated with the BIPM measurement results (y - axis) and the NMI gravimetric values (x -axis)



8 Key Comparison Reference Value

The following model for determining the reference values for the comparison was discussed and approved during the comparison participants' meeting on the Draft A1 report held on 30 June 2025.

The model is based on the approach that was adopted for CCQM-K82 in 2014, also coordinated by the BIPM, which consisted in the calculation of one reference value by standard, obtained by a Weighted Total Least Squares (WTLS) straight line regression of the pairs (x_{NMML}, R) , and selecting the largest consistent subset of points resulting in appropriate regression parameters². The measurement results obtained by CRDS were selected, since this method had the lowest measurement uncertainties. Reference values and degrees of equivalence determined from the GC-FID method show consistent results, but with enlarged uncertainties (See details in ANNEX II-).

8.1 Notation

The degree of equivalence is defined as:

$$D = x_{\text{NMI}} - x_{\text{KCRV}} \quad (1)$$

where

x_{KCRV} is the amount of substance fraction in the cylinder predicted by the linear analysis function for the corresponding analyzer response (ratio to the control cylinder with the CRDS);

$u(x_{\text{KCRV}})$ is the uncertainty of the predicted value;

x_{NMI} is the amount of substance fraction submitted by the participating laboratory;

$u(x_{\text{NMI}})$ is the standard uncertainty associated with the submitted value x_{NMI} ;

² The approach consisted of iteratively testing different data sets, localizing outliers, and subsequently redefining the working data set. At each step, the fit was evaluated using a statistical goodness-of-fit criterion, with subsets retained only if the goodness-of-fit value was less than 2. This procedure ensured that the final regression was based on the maximum number of mutually consistent points, thereby minimizing the influence of outliers and providing stable and statistically valid regression parameters.

8.2 Degrees of equivalence and graph of equivalence

The analysis of the data from the comparison was done following the procedures outlined in ISO 6143:2001² (Gas analysis – Comparison methods for determining and checking the composition of calibration gas mixtures). The regression analysis was performed with B_LEAST, a computer program which implemented the methodology of ISO 6143:2001, and takes into consideration uncertainties in both axes for regression analysis.

Standards that were to contribute to the KCRV were selected by applying the regression analysis first to the entire set of cylinders, so as to identify possible outliers, which then were not selected in the next set of data to be analysed. This process led to a self-consistent set of cylinders comprising all cylinders except cylinders UME-PSM034418, UME-PSM034390, NPLI-D001986, NPLI-D001989, NMISA-D679445 and NMISA-D733629 (NMISA's results showed a significant offset, leading to large uncertainty).

The goodness-of-fit of the regression performed with this data set is equal to 1.6 (see Table 7), demonstrating consistency of the ensemble. Key comparison reference values and degrees of equivalence are listed in Table 8. Degrees of equivalence are plotted in Figure 8. This resulted in four standards UME-PSM034418, UME-PSM034390, NPLI-D001986 and NPLI-D001989, not agreeing with the KCRV.

Table 7. Output from the GLS Algorithm in its Analysis Mode. b_0 , b_1 , $u(b_0)$, $u(b_1)$, and $cov(b_0, b_1)$ are the parameters of a straight-line model calibration function for the CRDS ratios to the control cylinder against x_{CH_4} values assigned by participants.

GLS parameter	Value
b_0 (nmol mol ⁻¹)	-0.39825
b_1	1816.40
$u(b_0)$ (nmol mol ⁻¹)	4.80
$u(b_1)$	4.34
$cov(b_0, b_1)$ (nmol mol ⁻¹)	-20.70
SSD rem	20.30
GOF	1.60

The comparison between the results obtained in 2014 and 2023, as shown in the equivalence graph Figure 9, demonstrates good consistency among participants. For each pair of standards, the degree of equivalence for the low amount of substance fraction standard is plotted before the high amount of substance fraction standard. This consistent performance highlights the reliability of the technical capabilities of participants over the past ten years.

Table 8. Degrees of equivalence for the key comparison CCQM-K82.2023

Participant	Cylinder	x_{KCRV}	$u(x_{\text{KCRV}})$	x_{NMI}	$u(x_{\text{NMI}})$	$D(x_{\text{NMI}} - x_{\text{KCRV}})$	$u(D)$	$U(D)$
		(nmol mol ⁻¹)	(nmol mol ⁻¹)	(nmol mol ⁻¹)	(nmol mol ⁻¹)	(nmol mol ⁻¹)	(nmol mol ⁻¹)	(nmol mol ⁻¹)
LNE	LNE-APE1126469	1813.90	0.41	1814.50	1.30	0.60	1.36	2.72
LNE	LNE-APE997315	2212.50	0.50	2213.10	1.50	0.60	1.58	3.16
NIM	NIM-L226018046	1812.40	0.41	1812.70	0.50	0.30	0.65	1.29
NIM	NIM-L226014004	2202.00	0.48	2202.10	0.60	0.10	0.77	1.54
NIMT	NIMT-D094433	1781.80	0.43	1785.08	2.50	3.28	2.54	5.07
NIMT	NIMT-D094436	2181.40	0.47	2184.90	2.84	3.50	2.88	5.76
VSL	VSL-D044000	1786.00	0.43	1787.29	1.79	1.29	1.84	3.68
VSL	VSL-D044373	2186.40	0.47	2187.86	2.19	1.46	2.24	4.48
NPL	NPL-D133091	1788.40	0.43	1789.60	0.85	1.20	0.95	1.90
NPL	NPL-D132886	2184.80	0.47	2186.60	1.04	1.80	1.14	2.28
KRISS	KRISS-D133520	1806.90	0.41	1805.75	0.68	-1.15	0.80	1.60
KRISS	KRISS-D133707	2204.50	0.49	2203.12	0.84	-1.38	0.97	1.94
NIST	NIST-FF68037	1788.50	0.43	1786.81	1.12	-1.69	1.20	2.40
NIST	NIST-FF68033	2201.80	0.48	2201.68	2.16	-0.12	2.21	4.43
NOAA	NOAA-FB04227	1815.20	0.41	1813.30	1.70	-1.90	1.75	3.50
NOAA	NOAA-FB04226	2203.80	0.49	2200.50	2.05	-3.30	2.11	4.21
NMISA	NMISA-D733629	1781.60	0.43	1813.00	22.50	31.40	22.50	45.01
NMISA	NMISA-D679445	2186.80	0.47	2218.00	28.50	31.20	28.50	57.01
NPLI	NPLI-D001986	1756.70	0.45	1787.45	5.09	30.75	5.10	10.21
NPLI	NPLI-D001989	2155.00	0.44	2199.66	4.02	44.66	4.04	8.09
UME	UME-PSM034418	1787.50	0.43	1794.50	1.57	7.00	1.63	3.25
UME	UME-PSM034390	2209.30	0.49	2216.51	2.15	7.21	2.21	4.41

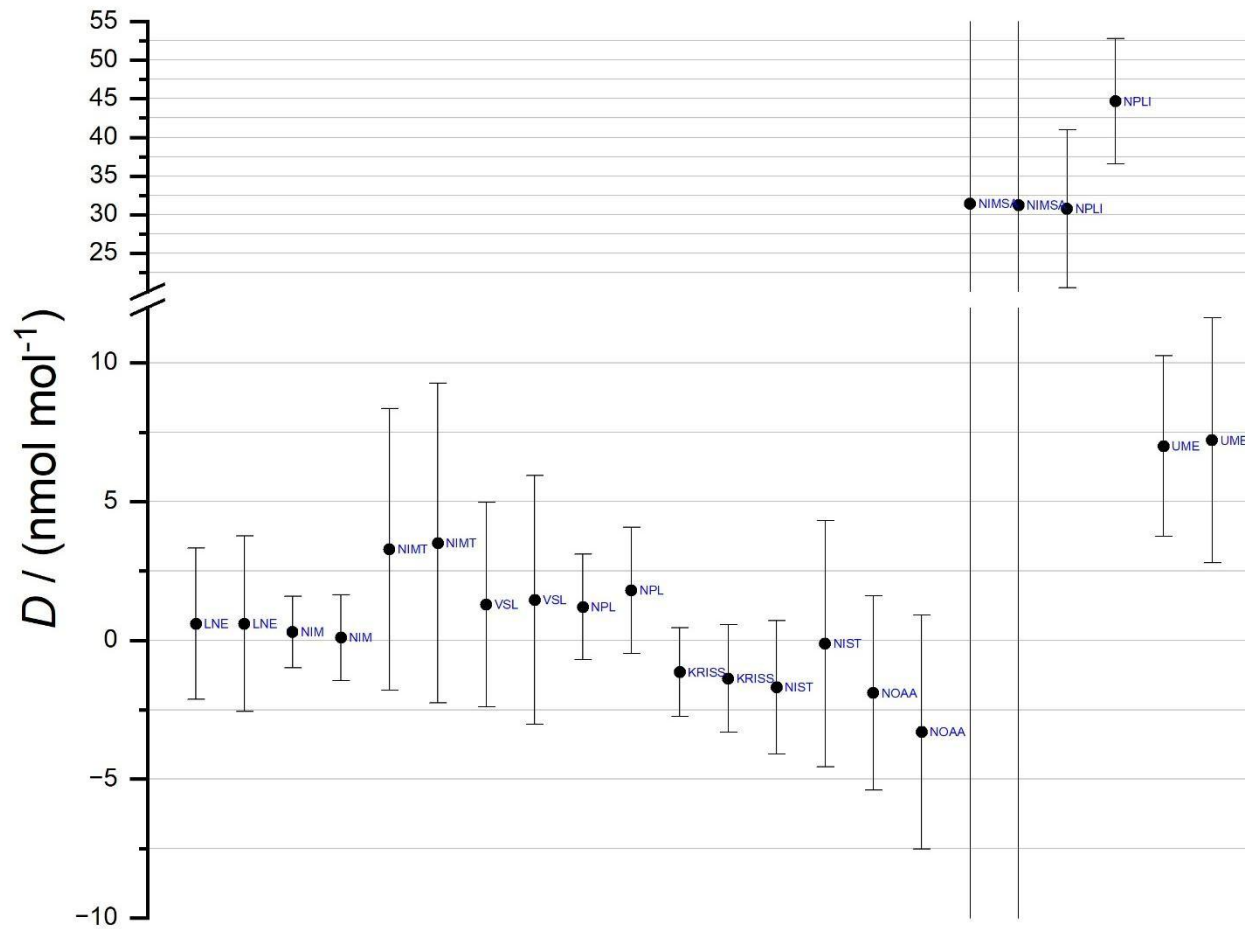

Figure 8. Graph of equivalence for the key comparison CCQM-K82.2023. The error bar represents the expanded uncertainty at a 95 % level of confidence. For the pair of standards the degree of equivalence for the low amount of substance fraction standard is plotted before the high amount of substance fraction standard.

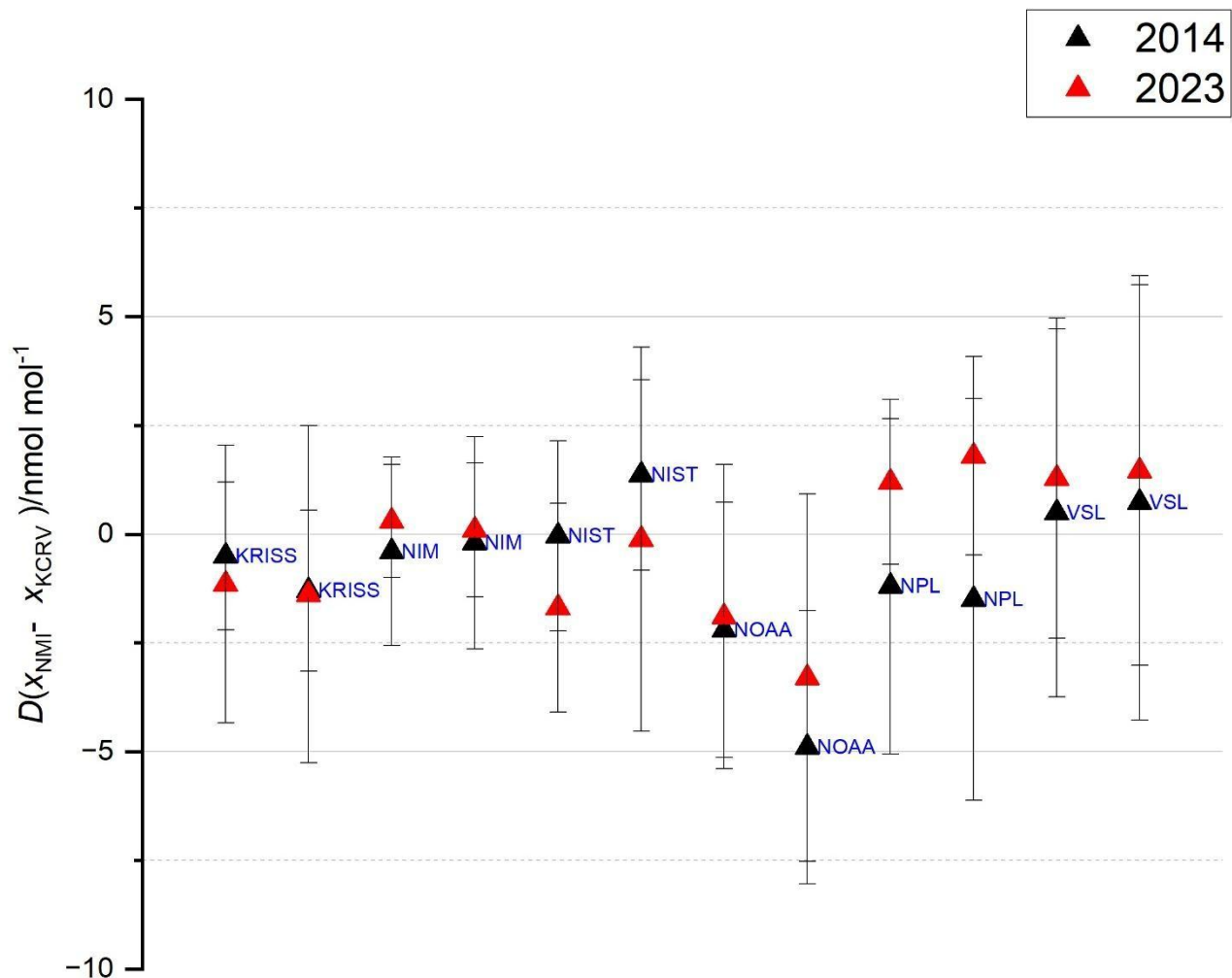

Figure 9. Graph of equivalence for the key comparison CCQM-K82 run on 2014 and the CCQM-K82.2023. The error bar represents the expanded uncertainty at a 95 % level of confidence. For the pair of standards the degree of equivalence for the low amount of substance fraction standard is plotted before the high amount of substance fraction standard.

8.3 Youden Plot

To assess both within-laboratory and between-laboratory variability, the equivalence of the data was also presented using a Youden Plot. In this plot, the degrees of equivalence for one standard from each participant are plotted against the degrees of equivalence for the other standard. The Youden plot displayed in Figure 10 shows the degrees of equivalence for the standards prepared with the higher CH₄ amount of substance fraction (around 2200 nmol mol⁻¹) versus the degree of equivalence for the standards prepared with the lower amount of substance fraction (around 1800 nmol mol⁻¹). The $y = x$ line of the plot represents the line on which completely correlated pairs of standards would lie.

Similar to the graph of equivalence, this plot shows that the standards UME-PSM034418 and UME-PSM034390 do not agree with the reference value (standards NPLI-D001986 and NPLI-D001989 show a significant deviation from the reference value, to the extent that they are beyond the range displayed on the plot). For the standards NMISA-D679445 and NMISA-D733629, their large uncertainties result in technical consistency with the reference value; however, they were also omitted from the plot to enhance clarity in the visual presentation of the results. In conclusion the rest of participants seem to be positioned uniformly around the $y = x$ line of the plot, demonstrating that the majority of laboratories have a relatively low within-laboratory variability.

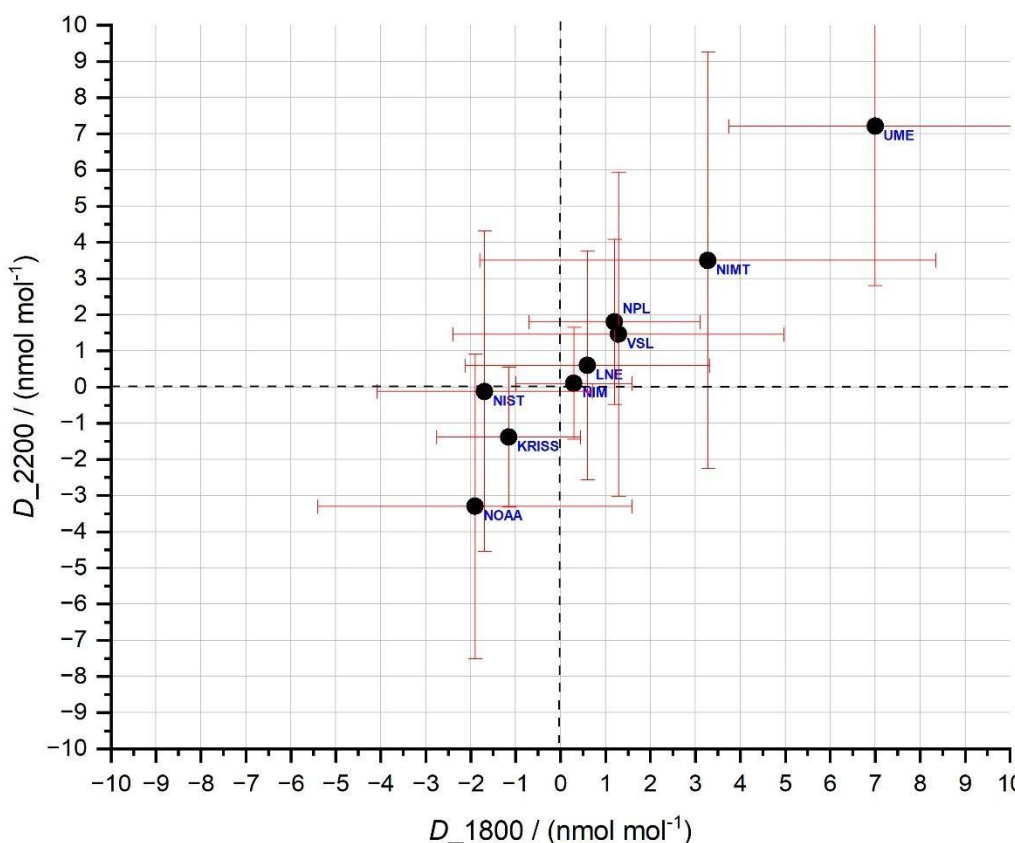

Figure 10. Youden Plot of the CCQM-K82.2023 results. The error bar represents the expanded uncertainty at a 95 % level of confidence.

9 Conclusions

The performance observed in the 2023 comparison is broadly consistent with that of the 2014 comparison, with participants demonstrating similar levels of capability.

Biases in pairs of standards were found to be highly correlated for several laboratories. In contrast, laboratories such as NIST and NOAA exhibited less correlation in the biases observed between their standard pairs. Notably, the amount fraction bias previously observed in 2014 for NOAA is no longer as evident in the 2023 results. Furthermore, NOAA showed improved agreement with the KCRV at higher amount fractions.

In terms of measurement uncertainty, the reported values remain comparable between the two comparisons, indicating no significant change in uncertainty levels over time. However, some participants, such as NIM, implemented significant methodological improvements, including a reduction in gravimetric preparation uncertainty and improved verification procedures, which enabled them to further reduce their overall uncertainties.

A persistent and significant contributor to the reported uncertainties continues to be the detection and quantification of trace levels of methane in the balance gases used for standard preparation.

Based on the Youden plot analysis, it can be concluded that biases in pairs of standards are almost identical for KRISS, NIM, LNE, VSL, NPL, NIMT, and UME. They appear less consistent for NOAA and NPLI, while distinct differences in biases were observed for NIST. In the case of NMISA, although not plotted due to the magnitude of the difference (covered by the uncertainty), the bias within the pair resulted also nearly identical.

10 'How far the light shines' statement

Similarly to 2014 the results of this key comparison could be used to support:

1. Claims of analytical capabilities for the measurement of methane in air or nitrogen in the range $1700 \text{ nmol mol}^{-1}$ to $2500 \text{ nmol mol}^{-1}$;
- 1) Claims of analytical capabilities for the measurement of methane in air in the range $2.5 \text{ } \mu\text{mol mol}^{-1}$ to 10 mmol mol^{-1} or in nitrogen in the range $2.5 \text{ } \mu\text{mol mol}^{-1}$ to $500 \text{ mmol mol}^{-1}$, following the guidance given in document GAWG19-41.

ANNEX I- CRDS uncertainty assessment for CCQM – K82.2023 standards

The formula to calculate the ratio to the control cylinder is

$$R_i = \frac{Cyl_i}{A(t_c)} \quad (2)$$

where Cyl_i is the instrument response to the cylinder i at the time t_c and $A(t_c)$ is the instrument response to the control cylinder at the same time t_c interpolated using a linear model in between measurements of the control cylinder made just before and after the cylinder i .

The uncertainties in the CRDS responses to cylinders i is constant (not dependent on the CRDS response) and a combination of the short-term repeatability, u_{Allan} , and the effect of the difference in air composition between measured gas mixtures (broadening effect),

u_{Broad} :

$$u(Cyl_i) = \sqrt{u_{Allan}^2 + u_{Broad}^2} \quad (3)$$

As described in the [CCQM-K82 Comparison report](#) (section 1.2.2), the short term repeatability was calculated by Allan Variance analysis, $u_{Alla} = 0.1$ ppb and the effect of the difference in air composition between measured gas mixtures was evaluated as $u_{Broad} = 0.059$ ppb (values are expressed in ppb to reflect that there are raw, uncalibrated responses of the instrument).

The uncertainty in the response to the control cylinder, $A(t_c)$, is considered equal to the short-term repeatability only.

$$u(A(t_c)) = u_{Allan} \quad (4)$$

Uncertainty of the ratio

The uncertainties on Cyl_i and $A(t_c)$ are first combined relatively

$$u(R_i) = R_i \sqrt{u(Cyl_i)^2 + u(A(t_c))^2} \quad (5)$$

This value is further combined with two other components: intermediate precision and potential biases due to isotope ratio effects, u_{iso} .

Intermediate precision

The intermediate precision is estimated from measurements of the two QC cylinder included at the start and end of each sequence. A rectangular distribution of width equal to the maximum difference between two values of the ratio R_i obtained on each of the QC cylinder is assumed. A typical relative uncertainty of 7.7×10^{-5} is obtained.

Potential biases due to isotope ratio effects, u_{iso}

During the first CCQM-K82 comparison we have concluded that assuming that pure methane used in the preparation of standards originates from natural gas, the reported mean isotopic delta values (± 1 SD) that could be expected is $-(43 \pm 7)$ ‰ for $\delta(^{13}\text{C})$ on the VPDB scale, and $-(185 \pm 20)$ ‰ for $\delta(^2\text{H})$ on the VSMOW scale. Gas samples at the extremes of this range would lead to biases in the CRDS measured methane amount fraction values of $+0.34 \text{ nmol mol}^{-1}$ and $-0.38 \text{ nmol mol}^{-1}$. Considering a rectangular probability distribution between these limits, allows a type B standard uncertainty to be calculated to cover potential variations in CRDS measurements occurring due to potentially different isotopic mixtures in the gas measured, $u_\delta = 0.21$ ppb. This can be converted to a standard uncertainty on the ratio equal to 1×10^{-4} on average.

Final combined uncertainty of the ratio

Combining all sources of uncertainty, the standard uncertainty for the ratio R_i appears to be almost constant and equal to 1.3×10^{-4} , corresponding to $0.24 \text{ nmol mol}^{-1}$ at a CH_4 amount fraction of $1800 \text{ nmol mol}^{-1}$.

ANNEX II- Application of GC-FID method to CCQM –K82.2023 standards

The CCQM-K82.2023 cylinders were analysed twice, first on April 8 and again on April 17, 2024. The April 8 ratios are listed in Table 10 and plotted in Figure 11, Figure 12, Figure 13 and Figure 14.

Unfortunately, different problems impacted on the quality and completion of the set of all cylinder measurements. In January 2024, a high-pressure side leak was identified during routine line preparation of cylinder NOAA-FB04226. Initial attempts to rectify the issue, including replacing a scratched connector, were unsuccessful, and a minor pressure loss continued on the cylinder gas line. To proceed with CRDS measurements, operational adjustments were implemented: enhanced oversight during working hours, controlled opening/closing times, and continuous monitoring to minimize gas depletion. Despite these actions, Cylinder NOAA-FB04226 was excluded from the GC-FID batch as a precaution, due to the significant risk of gas loss during GC-FID measurements.

A second event occurred during the preparation of cylinders for the measurements performed on April 8. The cylinder KRIS-D133520 was accidentally partially opened by the operator, resulting in insufficient pressure to properly flush the gas into the CRDS line. Consequently, the gas flow was compromised, and unreliable results were obtained. It was decided to discard the corresponding measurements.

In terms of the quality of the GC-FID measurements, it was noted that the noise levels were higher than those recorded in 2014, with typical relative uncertainties on the ratio R_{GC} equal to 5×10^{-4} instead of 2.5×10^{-4} . This probably reflects the performances of an instrument which was sparsely used between the two comparisons.

For each submitted cylinder, the difference from the reference value is defined as:

$$D = x_{NMI} - x_{GC} \quad (1)$$

where

x_{GC} is the reference value, obtained by applying the reference function for the corresponding analyzer response (ratio to the control cylinder with the GC-FID);

$u(x_{GC})$ is the uncertainty of the reference value;

x_{NMI} is the amount of substance fraction submitted by the participating laboratory;

$u(x_{NMI})$ is the standard uncertainty associated with the submitted value x_{NMI} ;

The regression analysis was performed with B_LEAST. Standards that were to contribute to the reference values were the same as CRDS, see section 7 (self-consistent set of cylinders comprising all cylinders except UME-PSM034418, UME-PSM034390, NPLI-D001986, NPLI-D001989, NMISA-D679445 and NMISA-D733629). In this special occasion, a quadratic function was chosen as model for the least-square regression in B_LEAST, as the GC-FID response was observed to be non-linear. Reference values x_{GC} and corresponding differences $Diff$ are listed in Table 11 and plotted in Figure 15. Similarly to measurements performed by CRDS, this resulted in four standards UME-PSM034418, UME-PSM034390, NPLI-D001986 and NPLI-D001989, for which the submitted values do not agree with the reference values.

Table 9. Output from the GLS Algorithm in its Analysis Mode. b_0 , b_1 and b_2 are the parameters of a quadratic model calibration function for the GC-FID responses against x_{CH_4} amount fractions.

Parameter	value
b_0 (nmol mol ⁻¹)	349.94
b_1 (nmol mol ⁻¹)	1157.4
b_2 (nmol mol ⁻¹)	307.43

Table 10. Participants cylinders assigned values and drift-corrected ratios to the control cylinder obtained by GC-FID.

Number of Cylinder	Assigned NMI's CH ₄ amount of substance fraction in (nmol mol ⁻¹)	Assigned NMI's Standard uncertainty ($k=1$) (nmol mol ⁻¹)	R_{GC} GC-FID Ratios to control cylinder	$u(R_{GC})$ Standard uncertainty in the Ratios to control cylinder
KRISS-D133707	2203.12	0.84	1.21034	0.00068
LNE-APE1126469	1814.50	1.30	0.99992	0.00076
LNE-APE997315	2213.10	1.50	1.21674	0.00074
NIM-L226018046	1812.70	0.50	0.99791	0.00070
NIM-L226014004	2202.10	0.60	1.20763	0.00084
NMISA-D733629	1813.00	22.50	0.98286	0.00109
NMISA-D679445	2218.00	28.50	1.20160	0.00087
NIMT-D094433	1785.08	2.50	0.98159	0.00072
NIMT-D094436	2184.90	2.84	1.19781	0.00081
NIST-FF68037	1786.81	1.12	0.98549	0.00075
NIST-FF68033	2201.68	2.16	1.21022	0.00065
NPL-D133091	1789.60	0.85	0.98625	0.00073
NPL-D132886	2186.60	1.04	1.20053	0.00091
NPLI-D001986	1787.45	5.09	0.96963	0.00061
NPLI-D001989	2199.66	4.02	1.18431	0.00075
UME-PSM034418	1794.50	1.57	0.98485	0.00069

UME-PSM034390	2216.51	2.15	1.21194	0.00106
VSL-D044000	1787.29	1.79	0.98415	0.00098
VSL-D044373	2187.86	2.19	1.20027	0.00064

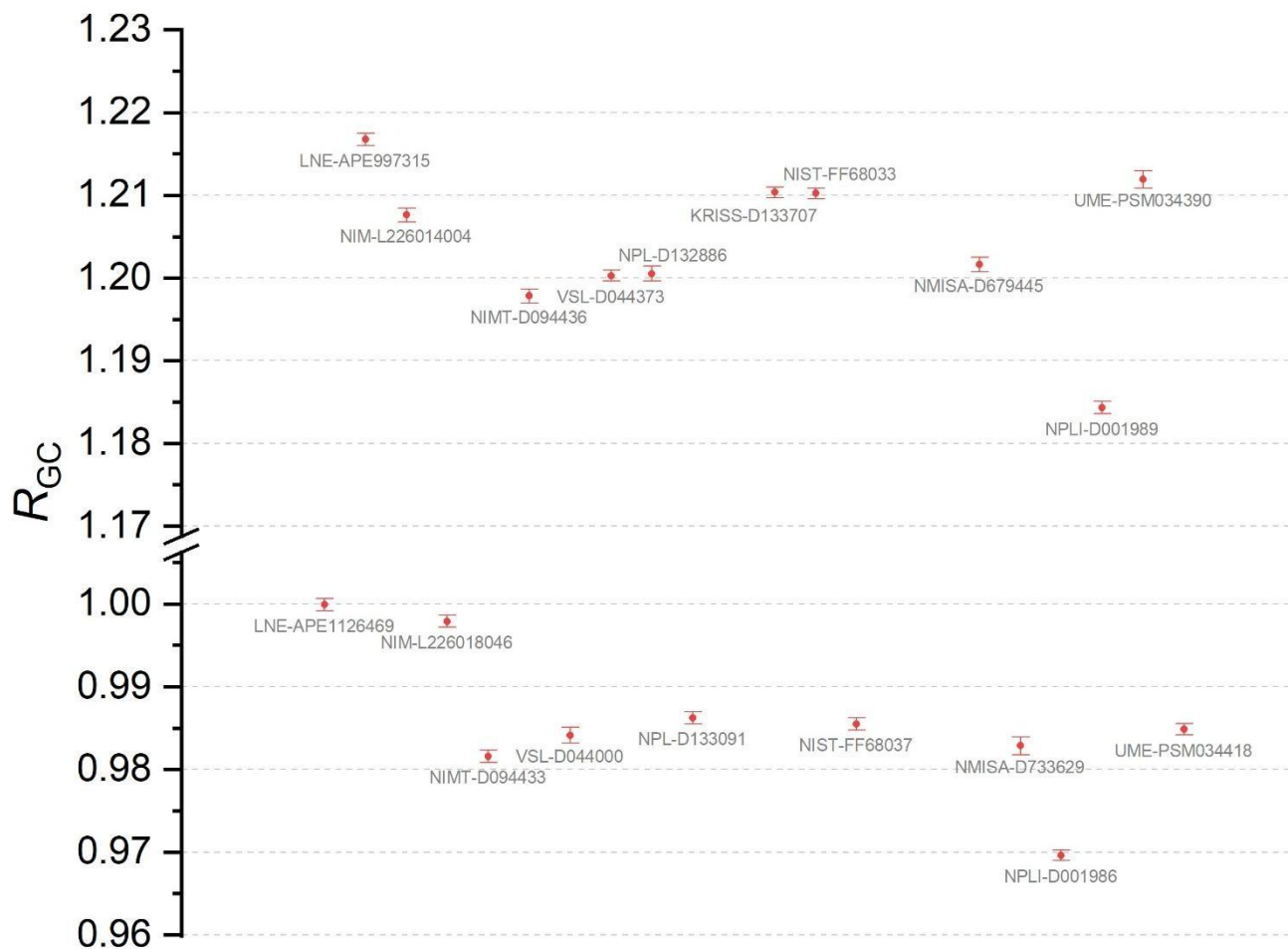

Figure 11 : GC-FID ratios to the control standard. The error bars represent the standard uncertainty ($k = 1$) associated with the BIPM measurement results.

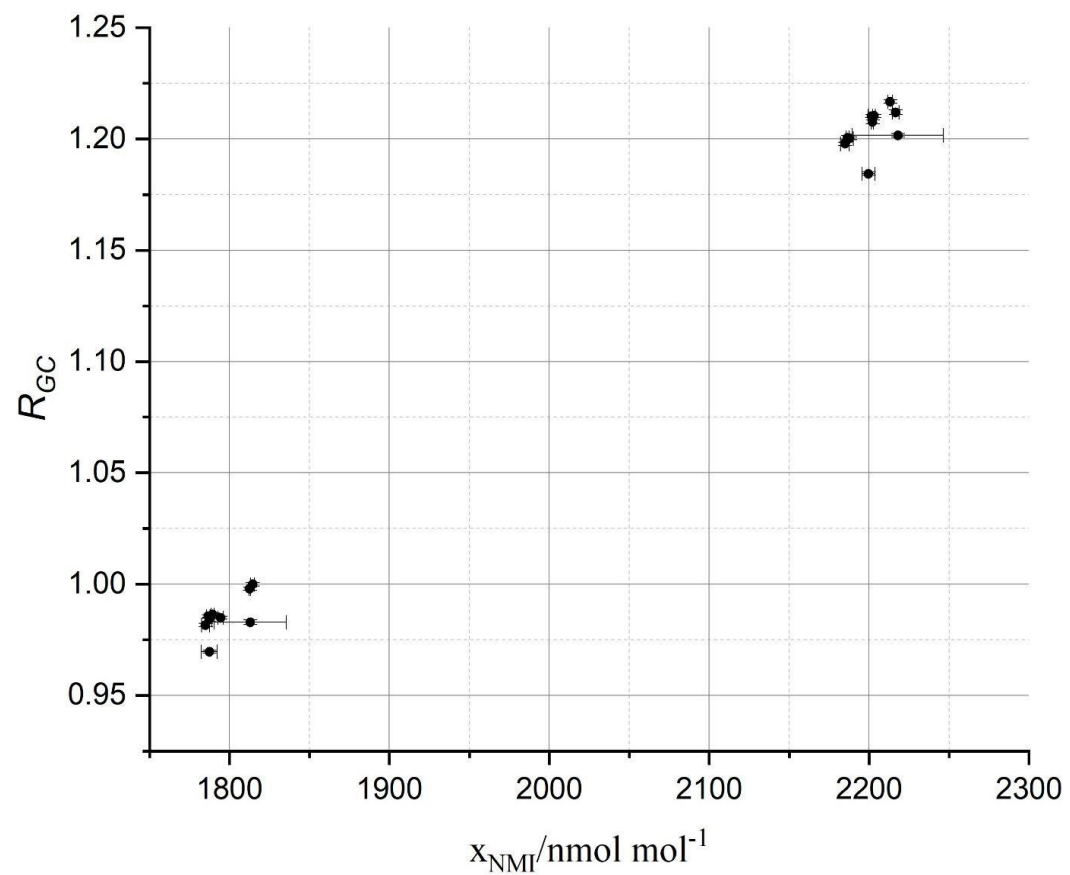

Figure 12. GC-FID ratios to control standard. The error bars represent the standard uncertainty ($k=1$) associated with the BIPM measurement results (y - axis) and the NMI gravimetric values (x -axis).

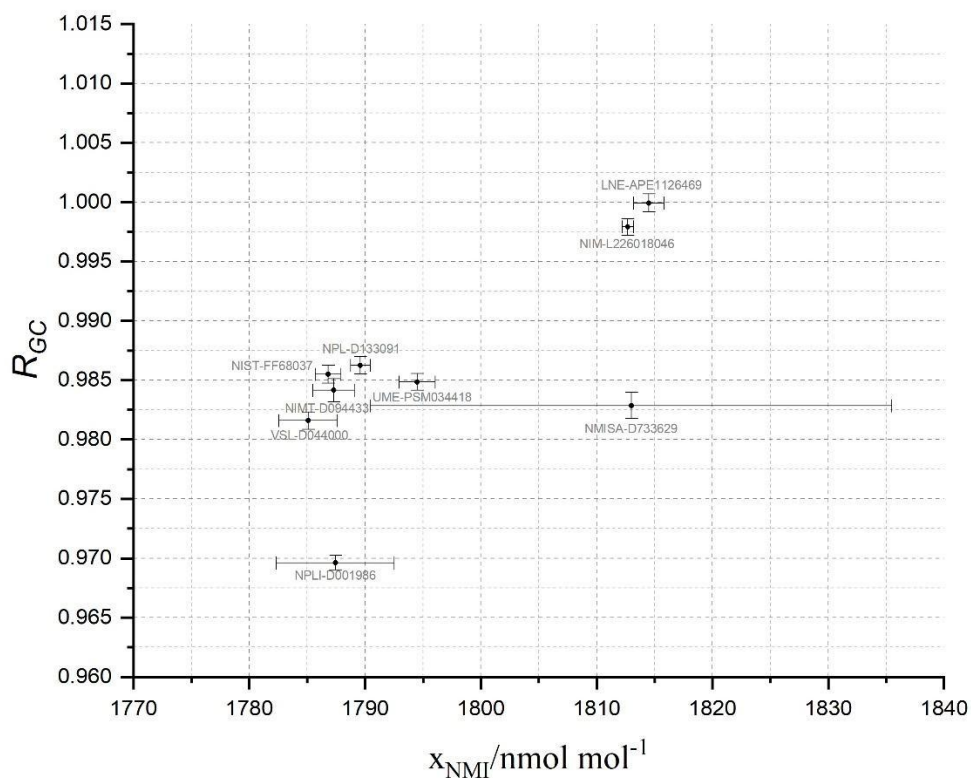

Figure 13. Zoom of the GC-FID ratios to control standard. The error bars represent the standard uncertainty ($k=1$) associated with the BIPM measurement results (y -axis) and the NMI gravimetric values (x -axis).

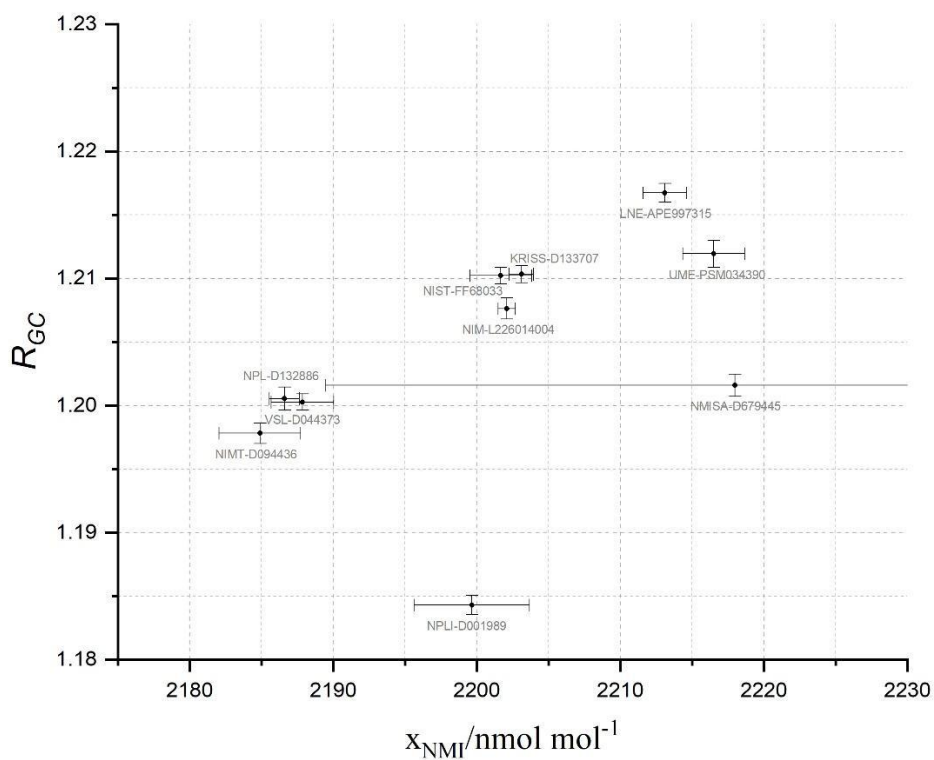

Figure 14. Zoom of the GC-FID ratios to control standard. The error bars represent the standard uncertainty ($k=1$) associated with the BIPM measurement results (y -axis) and the NMI gravimetric values (x -axis).

Table 11. Differences from the reference values obtained from measurements by GC-FID.

Participant	Cylinder	x_{GC}	$u(x_{GC})$	x_{NMI}	$u(x_{NMI})$	$Diff(x_{NMI} - x_{GC})$	$u(D)$	$U(D)$
		(nmol mol ⁻¹)	(nmol mol ⁻¹)	(nmol mol ⁻¹)	(nmol mol ⁻¹)	(nmol mol ⁻¹)	(nmol mol ⁻¹)	(k=2) (nmol mol ⁻¹)
NIM	NIM-L226014004	2199.40	1.62	2202.10	0.60	2.70	1.73	3.46
NIM	NIM-L226018046	1812.60	1.69	1812.70	0.50	0.10	1.77	3.53
NIMT	NIMT-D094433	1780.50	1.86	1785.08	2.50	4.58	3.12	6.23
NIMT	NIMT-D094436	2182.30	1.81	2184.90	2.84	2.60	3.37	6.74
VSL	VSL-D044000	1785.50	2.18	1787.29	1.79	1.79	2.82	5.64
VSL	VSL-D044373	2186.60	1.49	2187.86	2.19	1.26	2.65	5.29
NPL	NPL-D132886	2187.10	1.86	2186.60	1.04	-0.50	2.13	4.26
NPL	NPL-D133091	1789.70	1.70	1789.60	0.85	-0.10	1.90	3.80
KRISS	KRISS-D133707	2204.10	1.40	2203.12	0.84	-0.98	1.63	3.27
NIST	NIST-FF68033	2203.90	1.36	2201.68	2.16	-2.22	2.55	5.11
NIST	NIST-FF68037	1788.20	1.76	1786.81	1.12	-1.39	2.08	4.17
LNE	LNE-APE997315	2215.10	1.71	2213.10	1.50	-2.00	2.27	4.54
LNE	LNE-APE1126469	1816.50	1.85	1814.50	1.30	-2.00	2.26	4.52
NMISA	NMISA-D679445	2188.90	1.77	2218.00	28.50	29.10	28.55	57.11
NMISA	NMISA-D733629	1783.00	2.42	1813.00	22.50	30.00	22.63	45.26
NPLI	NPLI-D001986	1756.80	2.60	1787.45	5.09	30.65	5.71	11.42
NPLI	NPLI-D001989	2158.70	2.45	2199.66	4.02	40.96	4.71	9.41
UME	UME-PSM034390	2206.80	2.00	2216.51	2.15	9.71	2.94	5.88
UME	UME-PSM034418	1786.90	1.68	1794.50	1.57	7.60	2.30	4.59

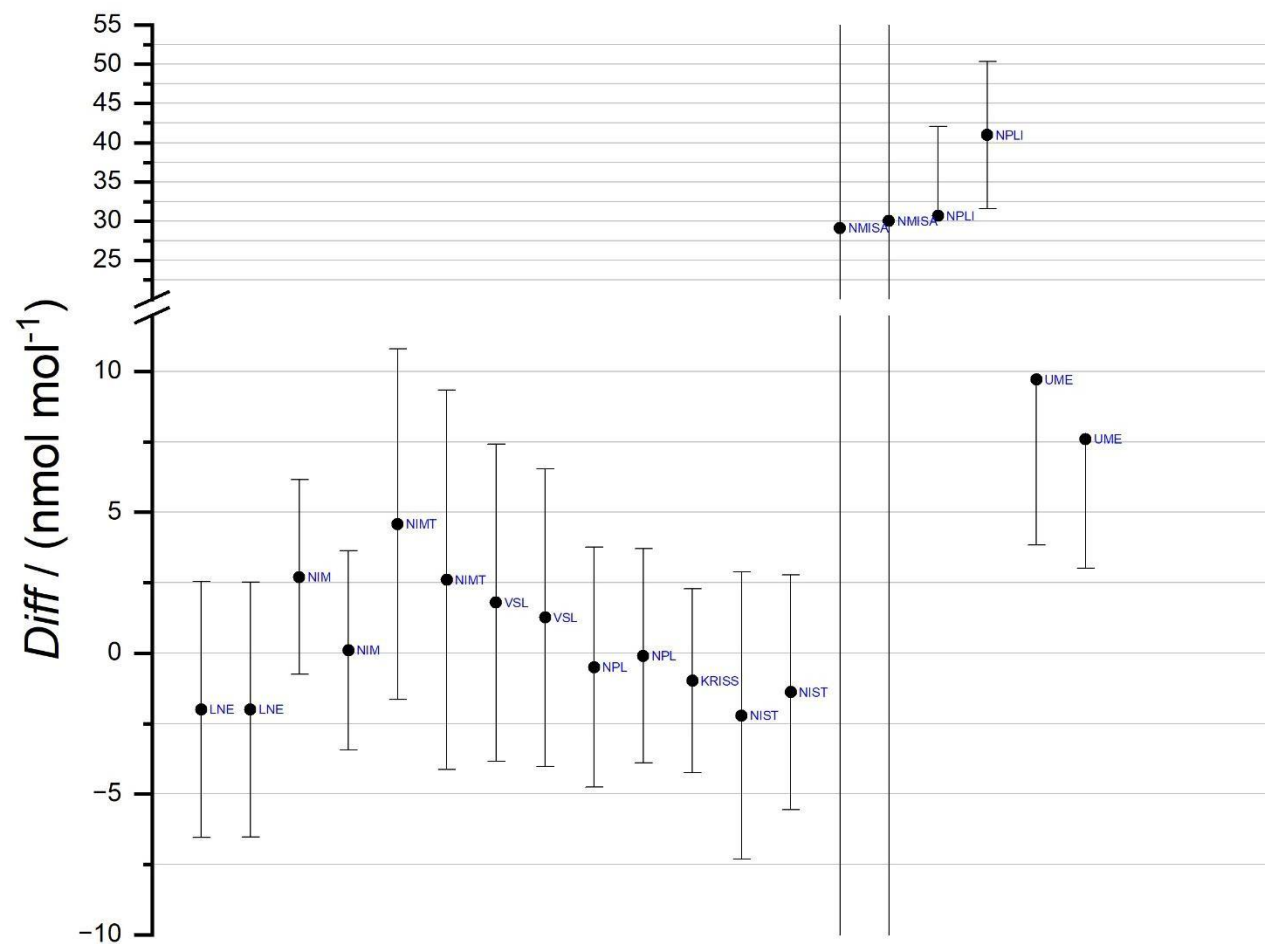

Figure 15. Differences from the reference values obtained from measurements by GC-FID. The error bar represents the expanded uncertainty at a 95 % level of confidence. For the pair of standards the degree of equivalence for the low amount of substance fraction standard is plotted before the high amount of substance fraction standard.

ANNEX III - Measurement reports of participants

Van Swinden Laboratorium (VSL)

Information to be submitted with mixtures

Key Comparison CCQM-K82.2023 Methane in Air at Ambient level (1800-2200) nmol/mol

Please complete this information sheet for each submitted standard and provide at least the information which is listed as mandatory below. Important: Failure to provide the mandatory information requested will exclude the standard from the set used to calculate the KCRV.

Institute	VSL	
Address	Thijsseweg 11 2629 JA Delft The Netherlands	
Contact	Adriaan van der Veen	
Email	avdveen@vsl.nl	
Telephone	+31 6 12021712	
Transfer Standards (cylinders) Information		

Standard #	ID (Serial Number)	Date of preparation	Pressure	(unit)
	VSL174000	2023-09-19	12.9	MPa
	VSL174373	2023-10-03	12.8	MPa

Mandatory information

a) Purity table with uncertainties for the nominally pure N₂, O₂, Ar or scrubbed Air and CO₂ parent/balance gases

Table 1: Purity analysis of argon

Component	x	u(x)	u _{rel} (x)
Argon	999999.9	0.033	0.0000033%
Methane	0.00065	0.00030	46%
Carbon monoxide	0.015	0.009	60%
Carbon dioxide	0.015	0.009	60%
Water	0.010	0.006	60%
Nitrogen	0.085	0.025	29%
Oxygen	0.005	0.003	60%

Table 2: Purity analysis of nitrogen (AP5908)

Component	x	u(x)	u _{rel} (x)
Argon	3.7	2.0	54%
Methane	0.00014	0.00020	143%
Carbon monoxide	0.00100	0.00060	60%
Carbon dioxide	0.0100	0.0060	60%
Hydrogen	0.025	0.015	60%
Water	0.0100	0.0060	60%
Nitrogen	999996.3	6.0	0.0006%
Oxygen	0.0050	0.0030	60%

Table 3: Purity table of nitrogen (AP2465)

Component	x	u(x)	u _{rel} (x)
Argon	3.3	1.0	31%
Methane	0.00013	0.00020	60%
Carbon monoxide	0.00100	0.00060	60%
Carbon dioxide	0.0100	0.0060	60%
Hydrogen	0.025	0.015	60%
Water	0.0100	0.0060	60%
Nitrogen	999996.7	6.0	0.0006%

Oxygen	0.0050	0.0030	60%
--------	--------	--------	-----

Table 4: Purity table of nitrogen (AL1890)

Component	x	u(x)	u _{rel} (x)
Argon	1.5	1.0	67%
Methane	0.00000	0.00020	200000000%
Carbon monoxide	0.00100	0.00060	60%
Carbon dioxide	0.0100	0.0006	6%
Hydrogen	0.025	0.015	60%
Water	0.0100	0.0060	60%
Nitrogen	999998.5	6.0	0.0006%
Oxygen	0.0050	0.0030	60%

Table 5: Purity table of nitrogen (APN26B)

Component	x	u(x)	u _{rel} (x)
Argon	5.0	3.0	60%
Methane	0.00100	0.00060	60%
Carbon monoxide	0.00100	0.00060	60%
Carbon dioxide	0.0100	0.0060	60%
Hydrogen	0.025	0.015	60%
Water	0.0100	0.0060	60%
Nitrogen	999994.9	6.0	0.0006%
Oxygen	0.0050	0.0030	60%

Table 6: Purity analysis of oxygen (AL5434)

Component	x	u(x)	u _{rel} (x)
Methane	0.00051	0.00030	59%
Carbon monoxide	0.10000	0.05800	58%
Carbon dioxide	0.10000	0.05800	58%
Hydrogen	0.1000	0.0580	58%
Water	0.500	0.029	6%
Oxygen	999999.20	0.30	0.000030%

Table 7: Purity analysis of carbon dioxide (AP5056)

Component	x	u(x)	u _{rel} (x)
Methane	0.100	0.060	60%
Carbon monoxide	0.50	0.30	60%
Carbon dioxide	999986.8	4.0	0.0004%
Water	1.70	0.30	18%

Nitrogen	6.1	3.1	51%
Oxygen	4.8	2.4	50%

b) Description of the traceability and measurement method for trace methane (critical impurity) in the pure parent/balance gases

The measurement of the amount fraction methane in the parent gases oxygen, argon and nitrogen was performed using cavity-ringdown spectroscopy (CRDS). The analytical method was described elsewhere [7]. The spectrometer is calibrated with a methane in nitrogen PSM with a methane amount fraction in the $\mu\text{mol mol}^{-1}$ range. Commonly found amount fraction levels in nitrogen are below 2 nmol mol^{-1} [7] whereas in oxygen this amount fraction is generally higher. The results of the purity analyses are provided in section a) of this report. The processing of data from purity analysis is done in accordance with ISO 19229 [3].

c) Purity table for each of the final mixtures including the value and uncertainty of the methane amount fraction which arises from the sum of trace methane that is a critical impurity in the pure parent/balance gases

Table 8: Composition of mixture VSL174000 based on gravimetric gas mixture preparation according to ISO 6142-1

Component	x	u(x)	$u_{rel}(x)$
Argon	9324.5	7.2	0.078%
Methane	1.78729	0.00020	0.011%
Carbon monoxide	0.023	0.012	54%
Carbon dioxide	370.74	0.06	0.016%
Ethene	0.00000045	0.00000025	56%
Ethane	0.00000045	0.00000025	56%
Propane	0.00000045	0.00000025	56%
hydrogen	0.040	0.016	39%
water	0.113	0.007	6.5%
Nitrogen	780745	10	0.0013%
Oxygen	209557.9	5.8	0.0028%

Table 9: Composition of mixture VSL174373 based on gravimetric gas mixture preparation according to ISO 6142-1

Component	x	u(x)	$u_{rel}(x)$
Argon	9320.4	7.2	0.078%
Methane	2.18786	0.00022	0.010%
Carbon monoxide	0.023	0.012	54%
Carbon dioxide	373.71	0.06	0.016%
Ethene	0.00000055	0.00000031	57%
Ethane	0.00000055	0.00000031	57%
Propane	0.00000055	0.00000031	57%
hydrogen	0.041	0.016	39%
water	0.114	0.007	6.5%
Nitrogen	779002	10	0.0013%
Oxygen	211302.1	5.7	0.0027%

d) Uncertainty budget for the final mixtures including gravimetric, stability, verification components and final combined uncertainty

Table 10: Uncertainty budget assigned value for the amount fraction methane in VSL174000. The relative standard uncertainty is given with respect to the amount fraction methane

Effect	x ($\mu\text{mol mol}^{-1}$)	$u_{\text{rel}}(x)$ (%)
Gas mixture preparation	1.78729	0.011
Mixture verification		0.10
Stability		0.00
Combined	1.78729	0.10

Table 11: Uncertainty budget assigned value for the amount fraction methane in VSL174373. The relative standard uncertainty is given with respect to the amount fraction methane

Effect	x ($\mu\text{mol mol}^{-1}$)	$u_{\text{rel}}(x)$ (%)
Gas mixture preparation	2.18786	0.011
Mixture verification		0.10
Stability		0.00
Combined	2.18786	0.10

Additional non-mandatory information:

e) Brief outline of the dilution series undertaken to produce the final mixtures

Mixture VSL174000 was prepared from

1. VSL278681 (carbon dioxide)
2. AL5434 (Oxygen)
3. VSL424447 (methane)
4. VSL640019 (argon)
5. AP2465 (nitrogen)

Mixture VSL 278681 (0.85 cmol mol⁻¹ carbon dioxide in nitrogen) was prepared from

- VSL260323 (carbon dioxide)
- APN26B (nitrogen)

Mixture VSL260323 (19 cmol mol⁻¹ carbon dioxide in nitrogen) was prepared from

- AP5056 (carbon dioxide)
- APN26B (nitrogen)

Mixture VSL244362 (50 μmol mol⁻¹ methane in nitrogen) was prepared from

- VSL528614 (methane) was prepared from
- APN26B (nitrogen)

VSL528614 (0.1 cmol mol⁻¹ methane in nitrogen) was prepared from

- VSL429403 (methane)
- APN26B (nitrogen)

VSL429403 (2.0 cmol mol⁻¹ methane in nitrogen) was prepared from

- VSL287605 (methane)
- APN26B (nitrogen)

VSL287605 (30 cmol mol⁻¹ methane in nitrogen) was prepared from

- APCH4 (methane)
- APN26B (nitrogen)

VSL640019 (25 cmol mol⁻¹ argon in nitrogen) was prepared from

- AP2194 (argon)
- APN26B (nitrogen)

Mixture VSL174373 was prepared from

1. VSL278681 (carbon dioxide)
2. AL5434 (Oxygen)
3. VSL424447 (methane)
4. VSL640019 (argon)
5. AP1890 (nitrogen)

VSL424447 (75 $\mu\text{mol mol}^{-1}$ methane in nitrogen)

- VSL528614 (methane)
- APN26B (nitrogen)

f) Purity table with uncertainties for the nominally pure CH₄ parent gas

Table 12: Purity table for methane (ALCH4)

Component	x	u(x)	U _{rel} (x)
Methane	999996.9	3.0	0.00030%
Carbon monoxide	0.050	0.029	58%
Carbon dioxide	0.050	0.029	58%
Ethene	0.25	0.14	56%
Ethane	0.25	0.14	56%
Propane	0.25	0.14	56%
Hydrogen	0.0500	0.0290	58%
Water	1.00	0.60	60%
Nitrogen	1.00	0.40	40%
Oxygen	0.20	0.10	50%

g) Brief outline of the verification procedure applied to the final mixtures

The verification of the gas mixtures was performed using a two-step procedure. In the first step, four bracketing calibration gas mixtures were verified against VSL's PSMs. In the second step, the bracketing mixtures were used to verify the travelling standards VSL174000 and VSL174373. The first verifications procedure were carried out in accordance with ISO 6143 [4]. Based on the verification results obtained so far, a relative standard uncertainty of 0.10 % was assigned.

Table 13: Relative deviations with respect to the amount fractions methane from gravimetry (%) in the three verification measurements

Date verification	VSL174000	VSL174373
05/10/2023	0.12%	0.05%
06/10/2023	0.06%	0.04%
08/10/2023	0.08%	-0.07%
Combined	0.09%	0.01%

h) Brief outline of any stability testing of the mixtures between the time they are prepared and the time they are shipped to the BIPM.

These mixtures do not exhibit any stability issues [5][6]. The mixtures have been verified about one month after preparation.

References

- [1] ISO 6142-1:2015 Gas analysis — Preparation of calibration gas mixtures — Part 1: Gravimetric method for Class I mixtures

- [2] ISO 6142-1:2015/Amd 1:2020 Gas analysis — Preparation of calibration gas mixtures — Part 1: Gravimetric method for Class I mixtures — Amendment 1: Corrections to formulae in Annex E and Annex G
- [3] ISO 19229:2019 Gas analysis — Purity analysis and the treatment of purity data
- [4] ISO 6143:2001 Gas analysis – Comparison methods for determining and checking the composition of calibration gas mixtures
- [5] Van der Veen A.M.H., Meuzelaar H., “Extrapolation of key comparison results in gas analysis”, Metrologia 58 (2021) 045004 (9pp), <https://iopscience.iop.org/article/10.1088/1681-7575/ac0312>
- [6] Zalewska E.T., Van der Veen A.M.H., Calibration and measurement capabilities for methane in nitrogen and air, VSL, Delft, The Netherlands, Technical Report S-CH.17.24, <https://www.vsl.nl/wp-content/uploads/2022/12/CMCs-for-methane-in-nitrogen-and-air.pdf>
- [7] Persijn S., Purity Analysis of Gases Used in the Preparation of Reference Gas Standards Using a Versatile OPO-Based CRDS Spectrometer, Journal of Spectroscopy, 2018, Article 9845608, 7 pp.
- [8] ISO 12963:2017 Gas analysis – Comparison methods for the determination of the composition of gas mixtures based on one- and two-point calibration

Cylinders Composition

CH₄ amount fraction

Complete the highlighted cells below with the value of the amount fraction of methane measured in each cylinder, expressed in nmol/mol, the associated expanded uncertainty and its coverage factor k

Standard #	Cylinder ID	x_{CH_4}	$U(x_{\text{CH}_4})$	k
		nmol/mol	nmol/mol	
1	VSL174000	1787.29	3.57	2.00
2	VSL174373	2187.86	4.38	2.00

Matrix Gas

Complete the cells below with the composition of the matrix gas

Indicate the amount fractions of the three major compounds

Compounds at trace levels may be indicated as well in the columns (other)

Indicate the unit in the cells

Compound	N ₂	O ₂	Ar	CO ₂	CO	H ₂ O
Standard #	ppm	ppm	ppm	ppm	ppm	ppm
1	780745.00	209557.90	9324.50	370.74	0.02	0.11
2	779002.00	211302.10	9320.40	373.71	0.02	0.11

Stability

Information to be submitted with mixtures

Key Comparison CCQM-K82.2023 Methane in Air at Ambient level (1800-2200) nmol/mol

Please complete this information sheet for each submitted standard and provide at least the information which is listed as mandatory below. Important: Failure to provide the mandatory information requested will exclude the standard from the set used to calculate the KCRV.

Institute	VSL			
Address	Thijssseweg 11 2629 JA Delft The Netherlands			
Contact	Adriaan van der Veen			
Email	avdveen@vsl.nl			
Telephone	+31 6 12021712			
Transfer Standards (cylinders) Information				
Standard #	ID (Serial Number)	Date of preparation	Pressure	(unit)
	VSL174000	2023-09-19	12.9	MPa
	VSL174373	2023-10-03	12.8	MPa

Mandatory information

a) Purity table with uncertainties for the nominally pure N₂, O₂, Ar or scrubbed Air and CO₂ parent/balance gases

Table 1: Purity analysis of argon (AP2194)

Component	x	u(x)	u _{rel} (x)
Argon	999999.9	0.033	0.0000033%
Methane	0.00065	0.00030	46%
Carbon monoxide	0.015	0.009	60%
Carbon dioxide	0.015	0.009	60%
Water	0.010	0.006	60%
Nitrogen	0.085	0.025	29%
Oxygen	0.005	0.003	60%

Table 2: Purity analysis of nitrogen (AP5908)

Component	x	u(x)	u _{rel} (x)
Argon	3.7	2.0	54%
Methane	0.00014	0.00020	143%
Carbon monoxide	0.00100	0.00060	60%
Carbon dioxide	0.0100	0.0060	60%
Hydrogen	0.025	0.015	60%
Water	0.0100	0.0060	60%
Nitrogen	999996.3	6.0	0.0006%
Oxygen	0.0050	0.0030	60%

Table 3: Purity table of nitrogen (AP2465)

Component	x	u(x)	u _{rel} (x)
Argon	3.3	1.0	31%
Methane	0.00013	0.00020	60%
Carbon monoxide	0.00100	0.00060	60%
Carbon dioxide	0.0100	0.0060	60%
Hydrogen	0.025	0.015	60%
Water	0.0100	0.0060	60%
Nitrogen	999996.7	6.0	0.0006%

Oxygen	0.0050	0.0030	60%
--------	--------	--------	-----

Table 4: Purity table of nitrogen (AL1890)

Component	x	u(x)	u _{rel} (x)
Argon	1.5	1.0	67%
Methane	0.00033	0.00020	60%
Carbon monoxide	0.00100	0.00060	60%
Carbon dioxide	0.0100	0.0006	6%
Hydrogen	0.025	0.015	60%
Water	0.0100	0.0060	60%
Nitrogen	999998.5	6.0	0.0006%
Oxygen	0.0050	0.0030	60%

Table 5: Purity table of nitrogen (APN26B)

Component	x	u(x)	u _{rel} (x)
Argon	5.0	3.0	60%
Methane	0.00100	0.00060	60%
Carbon monoxide	0.00100	0.00060	60%
Carbon dioxide	0.0100	0.0060	60%
Hydrogen	0.025	0.015	60%
Water	0.0100	0.0060	60%
Nitrogen	999994.9	6.0	0.0006%
Oxygen	0.0050	0.0030	60%

Table 6: Purity analysis of oxygen (AL5434)

Component	x	u(x)	u _{rel} (x)
Methane	0.00051	0.00030	59%
Carbon monoxide	0.10000	0.05800	58%
Carbon dioxide	0.10000	0.05800	58%
Hydrogen	0.1000	0.0580	58%
Water	0.500	0.029	6%
Oxygen	999999.20	0.30	0.000030%

Table 7: Purity analysis of carbon dioxide (AP5056)

Component	x	u(x)	u _{rel} (x)
Methane	0.100	0.060	60%
Carbon monoxide	0.50	0.30	60%
Carbon dioxide	999986.8	4.0	0.0004%
Water	1.70	0.30	18%

Nitrogen	6.1	3.1	51%
Oxygen	4.8	2.4	50%

b) Description of the traceability and measurement method for trace methane (critical impurity) in the pure parent/balance gases

The measurement of the amount fraction methane in the parent gases oxygen, argon and nitrogen was performed using cavity-ringdown spectroscopy (CRDS). The analytical method was described elsewhere [7]. The spectrometer is calibrated with a methane in nitrogen PSM with a methane amount fraction in the $\mu\text{mol mol}^{-1}$ range. Commonly found amount fraction levels in nitrogen are below 2 nmol mol^{-1} [7] whereas in oxygen this amount fraction is generally higher. The results of the purity analyses are provided in section a) of this report. The processing of data from purity analysis is done in accordance with ISO 19229 [3].

c) Purity table for each of the final mixtures including the value and uncertainty of the methane amount fraction which arises from the sum of trace methane that is a critical impurity in the pure parent/balance gases

Table 8: Composition of mixture VSL174000 based on gravimetric gas mixture preparation according to ISO 6142-1

Component	x	u(x)	u _{rel} (x)
Argon	9324.5	7.2	0.078%
Methane	1.78729	0.00020	0.011%
Carbon monoxide	0.023	0.012	54%
Carbon dioxide	370.74	0.06	0.016%
Ethene	0.00000045	0.00000025	56%
Ethane	0.00000045	0.00000025	56%
Propane	0.00000045	0.00000025	56%
hydrogen	0.040	0.016	39%
water	0.113	0.007	6.5%
Nitrogen	780745	10	0.0013%
Oxygen	209557.9	5.8	0.0028%

Table 9: Composition of mixture VSL174373 based on gravimetric gas mixture preparation according to ISO 6142-1

Component	x	u(x)	u _{rel} (x)
Argon	9320.4	7.2	0.078%
Methane	2.18786	0.00022	0.010%
Carbon monoxide	0.023	0.012	54%
Carbon dioxide	373.71	0.06	0.016%
Ethene	0.00000055	0.00000031	57%
Ethane	0.00000055	0.00000031	57%
Propane	0.00000055	0.00000031	57%
hydrogen	0.041	0.016	39%
water	0.114	0.007	6.5%
Nitrogen	779002	10	0.0013%
Oxygen	211302.1	5.7	0.0027%

d) Uncertainty budget for the final mixtures including gravimetric, stability, verification components and final combined uncertainty

Table 10: Uncertainty budget assigned value for the amount fraction methane in VSL174000. The relative standard uncertainty is given with respect to the amount fraction methane

Effect	x ($\mu\text{mol mol}^{-3}$)	$u_{rel}(x)$ (%)
Gas mixture preparation	1.78729	0.011
Mixture verification		0.10
Stability		0.00
Combined	1.78729	0.10

Table 11: Uncertainty budget assigned value for the amount fraction methane in VSL174373. The relative standard uncertainty is given with respect to the amount fraction methane

Effect	x ($\mu\text{mol mol}^{-3}$)	$u_{rel}(x)$ (%)
Gas mixture preparation	2.18786	0.011
Mixture verification		0.10
Stability		0.00
Combined	2.18786	0.10

Additional non-mandatory information:

e) Brief outline of the dilution series undertaken to produce the final mixtures

Mixture VSL174000 was prepared from

1. VSL278681 (carbon dioxide)
2. AL5434 (Oxygen)
3. VSL424447 (methane)
4. VSL640019 (argon)
5. AP2465 (nitrogen)

Mixture VSL 278681 (0.85 cmol mol⁻¹ carbon dioxide in nitrogen) was prepared from

- VSL260323 (carbon dioxide)
- APN26B (nitrogen)

Mixture VSL260323 (19 cmol mol⁻¹ carbon dioxide in nitrogen) was prepared from

- AP5056 (carbon dioxide)
- APN26B (nitrogen)

Mixture VSL244362 (50 μmol mol⁻¹ methane in nitrogen) was prepared from

- VSL528614 (methane) was prepared from
- APN26B (nitrogen)

VSL528614 (0.1 cmol mol⁻¹ methane in nitrogen) was prepared from

- VSL429403 (methane)
- APN26B (nitrogen)

VSL429403 (2.0 cmol mol⁻¹ methane in nitrogen) was prepared from

- VSL287605 (methane)
- APN26B (nitrogen)

VSL287605 (30 cmol mol⁻¹ methane in nitrogen) was prepared from

- APCH4 (methane)
- APN26B (nitrogen)

VSL640019 (25 cmol mol⁻¹ argon in nitrogen) was prepared from

- AP2194 (argon)
- APN26B (nitrogen)

Mixture VSL174373 was prepared from

1. VSL278681 (carbon dioxide)
2. AL5434 (Oxygen)
3. VSL424447 (methane)
4. VSL640019 (argon)
5. AP1890 (nitrogen)

VSL424447 (75 $\mu\text{mol mol}^{-1}$ methane in nitrogen)

- VSL528614 (methane)
- APN26B (nitrogen)

f) Purity table with uncertainties for the nominally pure CH_4 parent gas

Table 12: Purity table for methane (ALCH4)

Component	x	u(x)	$u_{rel}(x)$
Methane	999996.9	3.0	0.00030%
Carbon monoxide	0.050	0.029	58%
Carbon dioxide	0.050	0.029	58%
Ethene	0.25	0.14	56%
Ethane	0.25	0.14	56%
Propane	0.25	0.14	56%
Hydrogen	0.0500	0.0290	58%
Water	1.00	0.60	60%
Nitrogen	1.00	0.40	40%
Oxygen	0.20	0.10	50%

g) Brief outline of the verification procedure applied to the final mixtures

The verification of the gas mixtures was performed using a two-step procedure. In the first step, four bracketing calibration gas mixtures were verified against VSL's PSMs. In the second step, the bracketing mixtures were used to verify the travelling standards VSL174000 and VSL174373. The first verifications procedure were carried out in accordance with ISO 6143 [4]. Based on the verification results obtained so far, a relative standard uncertainty of 0.10 % was assigned.

Table 13: Relative deviations with respect to the amount fractions methane from gravimetry (%) in the first three verification measurements

Date verification	VSL174000	VSL174373
05/10/2023	0.12%	0.05%
06/10/2023	0.06%	0.04%
08/10/2023	0.08%	-0.07%
Combined	0.09%	0.01%

Table 14: Relative deviations with respect to the amount fractions methane from gravimetry (%) in the first three verification measurements

Date verification	VSL174000	VSL174373
12/08/2024	0.12%	0.11%
14/08/2024	0.06%	0.05%
16/08/2024	0.02%	-0.09%
Combined	0.07%	0.02%

h) Brief outline of any stability testing of the mixtures between the time they are prepared and the time they are shipped to the BIPM.

These mixtures do not exhibit any stability issues [5][6]. The mixtures have been verified about one month after preparation.

References

- [1] ISO 6142-1:2015 Gas analysis — Preparation of calibration gas mixtures — Part 1: Gravimetric method for Class I mixtures
- [2] ISO 6142-1:2015/Amd 1:2020 Gas analysis — Preparation of calibration gas mixtures — Part 1: Gravimetric method for Class I mixtures — Amendment 1: Corrections to formulae in Annex E and Annex G
- [3] ISO 19229:2019 Gas analysis — Purity analysis and the treatment of purity data
- [4] ISO 6143:2001 Gas analysis – Comparison methods for determining and checking the composition of calibration gas mixtures
- [5] Van der Veen A.M.H., Meuzelaar H., “Extrapolation of key comparison results in gas analysis”, Metrologia 58 (2021) 045004 (9pp), <https://iopscience.iop.org/article/10.1088/1681-7575/ac0312>
- [6] Zaleweska E.T., Van der Veen A.M.H., Calibration and measurement capabilities for methane in nitrogen and air, VSL, Delft, The Netherlands, Technical Report S-CH.17.24, <https://www.vsl.nl/wp-content/uploads/2022/12/CMCs-for-methane-in-nitrogen-and-air.pdf>
- [7] Persijn S., Purity Analysis of Gases Used in the Preparation of Reference Gas Standards Using a Versatile OPO-Based CRDS Spectrometer, Journal of Spectroscopy, 2018, Article 9845608, 7 pp.
- [8] ISO 12963:2017 Gas analysis – Comparison methods for the determination of the composition of gas mixtures based on one- and two-point calibration

Cylinders Composition

CH₄ amount fraction

Complete the highlighted cells below with the value of the amount fraction of methane measured in each cylinder, expressed in nmol/mol, the associated expanded uncertainty and its coverage factor k

Standard #	Cylinder ID	x_{CH_4}	$U(x_{\text{CH}_4})$	k
		nmol/mol	nmol/mol	
1	VSL174000	1787.29	3.57	2.00
2	VSL174373	2187.86	4.38	2.00

Matrix Gas

Complete the cells below with the composition of the matrix gas

Indicate the amount fractions of the three major compounds

Compounds at trace levels may be indicated as well in the columns (other)

Indicate the unit in the cells

Compound	N ₂	O ₂	Ar	CO ₂	CO	H ₂ O
Standard #	ppm	ppm	ppm	ppm	ppm	ppm
1	780745.00	209557.90	9324.50	370.74	0.02	0.11
2	779002.00	211302.10	9320.40	373.71	0.02	0.11

Korea Research Institute of Standards and Science (KRISS)

Information to be submitted with mixtures

Key Comparison CCQM-K82.2023 Methane in Air at Ambient level (1800-2200) nmol/mol

Please complete this information sheet for each submitted standard and provide at least the information which is listed as mandatory below. Important: Failure to provide the mandatory information requested will exclude the standard from the set used to calculate the KCRV.

Institute	Korea Research Institute of Standards and Science (KRISS)			
Address	267 Gajeong-ro Yuseong-gu, Daejeon 34113, Republic of Korea			
Contact	Kiryong Hong			
Email	khong@kriss.re.kr			
Telephone	+82-42-868-5236			
Transfer Standards (cylinders) Information				
Standard #	ID (Serial Number)	Date of preparation	Pressure	(unit)
1	D133520	2023-05-03	9.3	MPa
2	D133707	2023-05-03	9.3	MPa

Mandatory information

a) Purity table with uncertainties for the nominally pure N₂, O₂, Ar or scrubbed Air and CO₂ parent/balance gases

1. Purity table of nitrogen

Components	Amount fraction (μmol/mol)	Standard uncertainty (μmol/mol)
O ₂	0.159	0.003
Ar	4.901	0.005
CO ₂	0.010	0.002
CH ₄	0.0005	0.0001
N ₂ O	0.0005	0.0001
CO	0.008	0.001
He	0.11	0.02
H ₂	0.09	0.02
THC	0.00051	0.00002
H ₂ O	2.07	0.49
N₂	999992.65	0.49

2. Purity table of oxygen

Components	Amount fraction (μmol/mol)	Standard uncertainty (μmol/mol)
N ₂	0.28	0.07
Ar	0.17	0.04
CO ₂	0.008	0.002
CH ₄	0.000800	0.000006
N ₂ O	0.0005	0.0001
CO	0.095	0.001
He	0.11	0.03

H ₂	0.09	0.02
THC	0.00055	0.00009
H ₂ O	1.26	0.36
O₂	999997.98	0.37

3. Purity table of argon

Components	Amount fraction (μmol/mol)	Standard uncertainty (μmol/mol)
N ₂	0.33	0.11
O ₂	0.49	0.05
CO ₂	0.008	0.003
CH ₄	0.00011	0.00001
N ₂ O	0.0005	0.0002
CO	0.014	0.005
He	0.11	0.04
H ₂	0.09	0.03
THC	0.000160	0.000004
H ₂ O	1.21	0.48
Ar	999997.74	0.50

4. Purity table of carbon dioxide

Components	Amount fraction (μmol/mol)	Standard uncertainty (μmol/mol)
N ₂	0.96	0.04
O ₂	0.25	0.07
Ar	0.25	0.01
CH ₄	0.013	0.009
N ₂ O	0.0005	0.0002
CO	0.01	0.01
He	0.11	0.04

H ₂	0.09	0.03
THC	0.0199	0.0009
H ₂ O	2.60	1.04
CO ₂	999995.70	1.04

b) Description of the traceability and measurement method for trace methane (critical impurity) in the pure parent/balance gases;

To quantify the trace amount CH₄ in pure source gases, a cavity ring-down spectroscopy (CRDS) and a gas chromatograph with flame ionization detector (GC-FID) methods were employed for pure N₂, O₂, and Ar, and pure CO₂, respectively.

For the calibration of CRDS analyser (Picarro G2301), four KRISS primary reference materials (KRISS PRMs) of CH₄ in N₂ mixtures (0.1 µmol/mol, 0.5 µmol/mol, 1.0 µmol/mol, and 2.0 µmol/mol) were used. Using CRDS responses and gravimetric values of KRISS PRMs, the generalized least-squares method was performed by XGenline (NPL software). The first-order linear fit from the generalized least-squares method, the uncertainties of slope and y-axis intercept were obtained. After that the critical impurity, CH₄, in pure gases, N₂, O₂, and Ar, was measured by CRDS and the amount fraction and its uncertainty of CH₄ impurity in each pure gas was calculated using linear fit and uncertainties of slope and y-axis. The amount fractions of CH₄ in pure N₂, O₂, and Ar and its standard uncertainties were listed in the above section a).

The GC-FID was employed to measure the CH₄ impurity in pure CO₂. The KRISS PRM of 3 µmol/mol CH₄ in N₂ was used as the calibration gas mixture and one-point calibration method was performed. The analytical conditions were listed in below table.

Analytical conditions

Detector	Flame ionization detector (FID)
Column	M55A (2.74 m x 3)
Carrier gas	N ₂ , 0.41 MPa, 35.1 ml/min
Oven temp.	70 °C (12 min)
Detector temp.	250 °C
Sample loop	5 ml

The CH₄ amount fraction in CO₂ was listed in the above section a).

c) Purity table for each of the final mixtures including the value and uncertainty of the methane amount fraction which arises from the

sum of trace methane that is a critical impurity in the pure parent/balance gases

The amount fraction of each component and its uncertainty listed in the below tables were calculated with the purity of source gases (N₂, O₂, Ar, CO₂, and CH₄), atomic weights, and weighing data.

1. Purity table of final mixture (D133520)

Components	Amount fraction (μmol/mol)	Standard uncertainty (μmol/mol)
N ₂	779548.70	16.10
O ₂	210487.22	9.52
Ar	9562.40	14.20
CO ₂	397.76	0.06
N ₂ O	0.00050	0.00007
CO	0.026	0.001
He	0.11	0.02
H ₂	0.09	0.01
THC	0.00053	0.00002
H ₂ O	1.89	0.34
CH₄	1.80575	0.00033

2. Purity table of final mixture (D133707)

Components	Amount fraction (μmol/mol)	Standard uncertainty (μmol/mol)
N ₂	780112.00	15.70
O ₂	210271.31	9.42
Ar	9241.70	13.80
CO ₂	370.69	0.05
N ₂ O	0.00050	0.00007
CO	0.026	0.001
He	0.11	0.02
H ₂	0.09	0.01

THC	0.00053	0.00002
H ₂ O	1.90	0.34
CH ₄	2.20312	0.00040

d) Uncertainty budget for the final mixtures including gravimetric, stability, verification components and final combined uncertainty

Uncertainty budget for the final mixtures

Cylinder ID	Uncertainty component	Standard uncertainty / nmol/mol	Contribution to uncertainty / %
D133520	Analytical repeatability	0.017	0.06
	Analytical reproducibility	0.603	76.68
	Gravimetric uncertainty	0.332	23.27
	Combined	0.684	
D133707	Analytical repeatability	0.026	0.09
	Analytical reproducibility	0.735	22.73
	Gravimetric uncertainty	0.399	77.18
	Combined	0.837	

Additional non-mandatory information:

e) Brief outline of the dilution series undertaken to produce the final mixtures

Six CH₄ in synthetic air mixtures, which are three of 1800 nmol/mol and another three of 2200 nmol/mol level, were gravimetrically prepared in accordance with ISO 6142-1. The automated top-pan balance (XP26003L, Mettler Toledo) was used to determine the masses of introduced gases, and its capacity and resolution are 26 kg and 1 mg, respectively. CH₄ in N₂, CO₂ in N₂, Ar in N₂ gas mixtures were firstly prepared with 1 or 3 dilution steps from sources in order to prepare the final mixtures of CH₄ in synthetic air. After that the mixtures and pure O₂ gases were blended and finally diluted with pure N₂ gas. After all dilution steps were completed, the mixtures were analysed for the verification. For preparation of final mixtures, the aluminium (Al) cylinders (Luxfer, UK) were used. The hierarchy of gravimetric preparation of ambient CH₄ in synthetic air mixtures was shown in Figure 1.

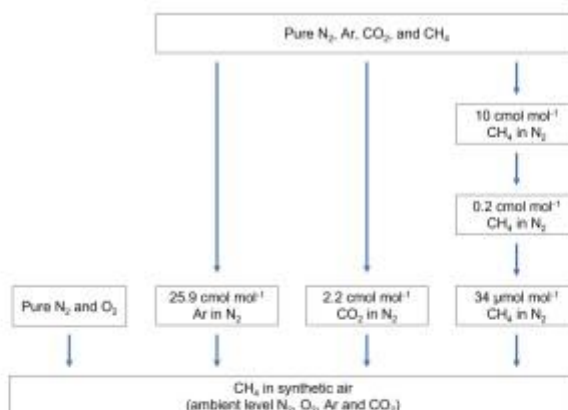

Figure 1. A hierarchy of gravimetric preparation of ambient CH₄ in synthetic air mixtures.

f) Purity table with uncertainties for the nominally pure CH₄ parent gas

Purity table of methane

Components	Amount fraction (μmol/mol)	Standard uncertainty (μmol/mol)
N ₂	2.13	0.04
O ₂	0.22	0.02
Ar	0.19	0.03
CO ₂	0.016	0.005
N ₂ O	0.0005	0.0002
CO	0.007	0.002
He	0.133	0.006
H ₂	0.09	0.03
THC	0.00286	0.00007
H ₂ O	2.75	1.10
CH₄	999994.46	1.10

g) Brief outline of the verification procedure applied to the final mixtures

The CRDS analyser was used for the verification of six mixtures for CH₄ in synthetic air. The CRDS analyser was calibrated with KRISS PRMs of ambient CH₄ in air before the verification. One of the final mixtures was used as working standard (D148519), and other 5 mixtures (D133520, D133611, D133448, D133707, and D133529) were used as sample mixtures. The sample mixtures were analysed against the working standard by alternating between the standard and sample (i.e., A-B-A, where A is the working standard, B is the sample mixture). The verification result was shown in Figure 2.

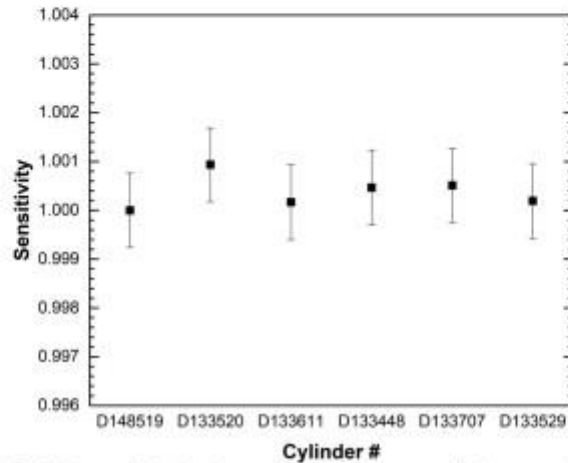

Figure 2. Verification result for CH₄ in synthetic air mixtures (error bars represent their preparation uncertainty ($k = 2$)).

h) Brief outline of any stability testing of the mixtures between the time they are prepared and the time they are shipped to the BIPM.

Cylinders Composition

CH₄ amount fraction

Complete the highlighted cells below with the value of the amount fraction of methane measured in each cylinder, expressed in nmol/mol, the associated expanded uncertainty and its coverage factor k

Standard #	Cylinder ID	x_{CH_4}	$U(x_{\text{CH}_4})$	k
		nmol/mol	nmol/mol	
1	D133520	1805.75	1.37	2.00
2	D133707	2203.12	1.67	2.00

Matrix Gas

Complete the cells below with the composition of the matrix gas

Indicate the amount fractions of the three major compounds

Compounds at trace levels may be indicated as well in the columns (other)

Indicate the unit in the cells

Compound	N ₂	O ₂	Ar	CO ₂	CO	H ₂ O
Standard #	cmol/mol	cmol/mol	cmol/mol	μmol/mol	μmol/mol	μmol/mol
1	77.95	21.05	0.96	397.76	0.03	1.89
2	78.01	21.03	0.92	370.69	0.03	1.90

Stability

Information to be submitted with mixtures

Key Comparison CCQM-K82.2023 Methane in Air at Ambient level (1800-2200) nmol/mol

Please complete this information sheet for each submitted standard and provide at least the information which is listed as mandatory below. Important: Failure to provide the mandatory information requested will exclude the standard from the set used to calculate the KCRV.

Institute	Korea Research Institute of Standards and Science (KRISS)			
Address	267 Gajeong-ro Yuseong-gu, Daejeon 34113, Republic of Korea			
Contact	Kiryong Hong			
Email	khong@kriss.re.kr			
Telephone	+82-42-868-5236			
Transfer Standards (cylinders) Information				
Standard #	ID (Serial Number)	Date of preparation	Pressure	(unit)
1	D133520	2023-05-03	9.3	MPa
2	D133707	2023-05-03	9.3	MPa

Mandatory information

a) Purity table with uncertainties for the nominally pure N₂, O₂, Ar or scrubbed Air and CO₂ parent/balance gases

1. Purity table of nitrogen

Components	Amount fraction (μmol/mol)	Standard uncertainty (μmol/mol)
O ₂	0.159	0.003
Ar	4.901	0.005
CO ₂	0.010	0.002
CH ₄	0.0005	0.0001
N ₂ O	0.0005	0.0001
CO	0.008	0.001
He	0.11	0.02
H ₂	0.09	0.02
THC	0.00051	0.00002
H ₂ O	2.07	0.49
N₂	999992.65	0.49

2. Purity table of oxygen

Components	Amount fraction (μmol/mol)	Standard uncertainty (μmol/mol)
N ₂	0.28	0.07
Ar	0.17	0.04
CO ₂	0.008	0.002
CH ₄	0.000800	0.000006
N ₂ O	0.0005	0.0001
CO	0.095	0.001
He	0.11	0.03

H ₂	0.09	0.02
THC	0.00055	0.00009
H ₂ O	1.26	0.36
O ₂	999997.98	0.37

3. Purity table of argon

Components	Amount fraction (μmol/mol)	Standard uncertainty (μmol/mol)
N ₂	0.33	0.11
O ₂	0.49	0.05
CO ₂	0.008	0.003
CH ₄	0.00011	0.00001
N ₂ O	0.0005	0.0002
CO	0.014	0.005
He	0.11	0.04
H ₂	0.09	0.03
THC	0.000160	0.000004
H ₂ O	1.21	0.48
Ar	999997.74	0.50

4. Purity table of carbon dioxide

Components	Amount fraction (μmol/mol)	Standard uncertainty (μmol/mol)
N ₂	0.96	0.04
O ₂	0.25	0.07
Ar	0.25	0.01
CH ₄	0.013	0.009
N ₂ O	0.0005	0.0002
CO	0.01	0.01
He	0.11	0.04

H ₂	0.09	0.03
THC	0.0199	0.0009
H ₂ O	2.60	1.04
CO ₂	99995.70	1.04

b) Description of the traceability and measurement method for trace methane (critical impurity) in the pure parent/balance gases;

To quantify the trace amount CH₄ in pure source gases, a cavity ring-down spectroscopy (CRDS) and a gas chromatograph with flame ionization detector (GC-FID) methods were employed for pure N₂, O₂, and Ar, and pure CO₂, respectively.

For the calibration of CRDS analyser (Picarro G2301), four KRISS primary reference materials (KRISS PRMs) of CH₄ in N₂ mixtures (0.1 µmol/mol, 0.5 µmol/mol, 1.0 µmol/mol, and 2.0 µmol/mol) were used. Using CRDS responses and gravimetric values of KRISS PRMs, the generalized least-squares method was performed by XGenline (NPL software). The first-order linear fit from the generalized least-squares method, the uncertainties of slope and y-axis intercept were obtained. After that the critical impurity, CH₄, in pure gases, N₂, O₂, and Ar, was measured by CRDS and the amount fraction and its uncertainty of CH₄ impurity in each pure gas was calculated using linear fit and uncertainties of slope and y-axis. The amount fractions of CH₄ in pure N₂, O₂, and Ar and its standard uncertainties were listed in the above section a).

The GC-FID was employed to measure the CH₄ impurity in pure CO₂. The KRISS PRM of 3 µmol/mol CH₄ in N₂ was used as the calibration gas mixture and one-point calibration method was performed. The analytical conditions were listed in below table.

Analytical conditions

Detector	Flame ionization detector (FID)
Column	MSSA (2.74 m x 3)
Carrier gas	N ₂ , 0.41 MPa, 35.1 ml/min
Oven temp.	70 °C (12 min)
Detector temp.	250 °C
Sample loop	5 ml

The CH₄ amount fraction in CO₂ was listed in the above section a).

c) Purity table for each of the final mixtures including the value and uncertainty of the methane amount fraction which arises from the

sum of trace methane that is a critical impurity in the pure parent/balance gases

The amount fraction of each component and its uncertainty listed in the below tables were calculated with the purity of source gases (N₂, O₂, Ar, CO₂, and CH₄), atomic weights, and weighing data.

1. Purity table of final mixture (D133520)

Components	Amount fraction (μmol/mol)	Standard uncertainty (μmol/mol)
N ₂	779548.70	16.10
O ₂	210487.22	9.52
Ar	9562.40	14.20
CO ₂	397.76	0.06
N ₂ O	0.00050	0.00007
CO	0.026	0.001
He	0.11	0.02
H ₂	0.09	0.01
THC	0.00053	0.00002
H ₂ O	1.89	0.34
CH₄	1.80575	0.00033

2. Purity table of final mixture (D133707)

Components	Amount fraction (μmol/mol)	Standard uncertainty (μmol/mol)
N ₂	780112.00	15.70
O ₂	210271.31	9.42
Ar	9241.70	13.80
CO ₂	370.69	0.05
N ₂ O	0.00050	0.00007
CO	0.026	0.001
He	0.11	0.02
H ₂	0.09	0.01

THC	0.00053	0.00002
H ₂ O	1.90	0.34
CH ₄	2.20312	0.00040

d) Uncertainty budget for the final mixtures including gravimetric, stability, verification components and final combined uncertainty

Uncertainty budget for the final mixtures

Cylinder ID	Uncertainty component	Standard uncertainty / nmol/mol	Contribution to uncertainty / %
D133520	Analytical repeatability	0.017	0.06
	Analytical reproducibility	0.603	76.68
	Gravimetric uncertainty	0.332	23.27
	Combined	0.684	
D133707	Analytical repeatability	0.026	0.09
	Analytical reproducibility	0.735	22.73
	Gravimetric uncertainty	0.399	77.18
	Combined	0.837	

Additional non-mandatory information:

e) Brief outline of the dilution series undertaken to produce the final mixtures

Six CH₄ in synthetic air mixtures, which are three of 1800 nmol/mol and another three of 2200 nmol/mol level, were gravimetrically prepared in accordance with ISO 6142-1. The automated top-pan balance (XP26003L, Mettler Toledo) was used to determine the masses of introduced gases, and its capacity and resolution are 26 kg and 1 mg, respectively. CH₄ in N₂, CO₂ in N₂, Ar in N₂ gas mixtures were firstly prepared with 1 or 3 dilution steps from sources in order to prepare the final mixtures of CH₄ in synthetic air. After that the mixtures and pure O₂ gases were blended and finally diluted with pure N₂ gas. After all dilution steps were completed, the mixtures were analysed for the verification. For preparation of final mixtures, the aluminium (Al) cylinders (Luxfer, UK) were used. The hierarchy of gravimetric preparation of ambient CH₄ in synthetic air mixtures was shown in Figure 1.

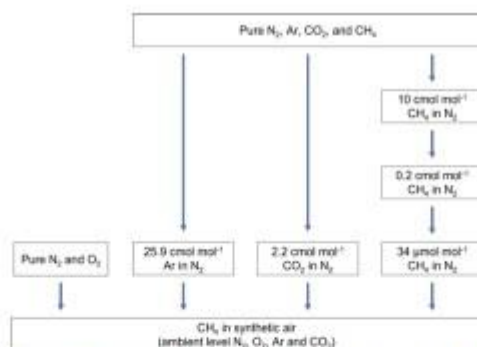

Figure 1. A hierarchy of gravimetric preparation of ambient CH₄ in synthetic air mixtures.

f) Purity table with uncertainties for the nominally pure CH₄ parent gas

Purity table of methane

Components	Amount fraction (μmol/mol)	Standard uncertainty (μmol/mol)
N ₂	2.13	0.04
O ₂	0.22	0.02
Ar	0.19	0.03
CO ₂	0.016	0.005
N ₂ O	0.0005	0.0002
CO	0.007	0.002
He	0.133	0.006
H ₂	0.09	0.03
THC	0.00286	0.00007
H ₂ O	2.75	1.10
CH ₄	999994.46	1.10

g) Brief outline of the verification procedure applied to the final mixtures

The CRDS analyser was used for the verification of six mixtures for CH₄ in synthetic air. The CRDS analyser was calibrated with KRIS PRMs of ambient CH₄ in air before the verification. One of the final mixtures was used as working standard (D148519), and other 5 mixtures (D133520, D133611, D133448, D133707, and D133529) were used as sample mixtures. The sample mixtures were analysed against the working standard by alternating between the standard and sample (i.e., A-B-A, where A is the working standard, B is the sample mixture). The verification result was shown in Figure 2.

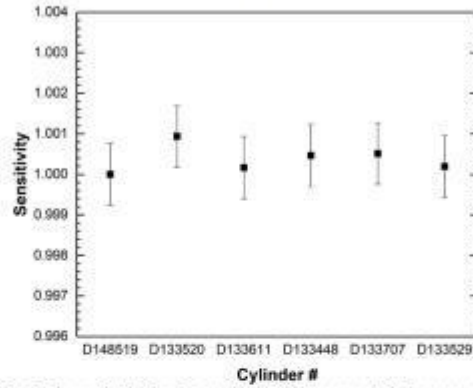

Figure 2. Verification result for CH₄ in synthetic air mixtures (error bars represent their preparation uncertainties ($k = 2$)).

Two methane standards (D133520 and D133707) were verified again to figure out their internal consistency after they returned to KRIS using same verification procedure above. The verification result was shown in Figure 3.

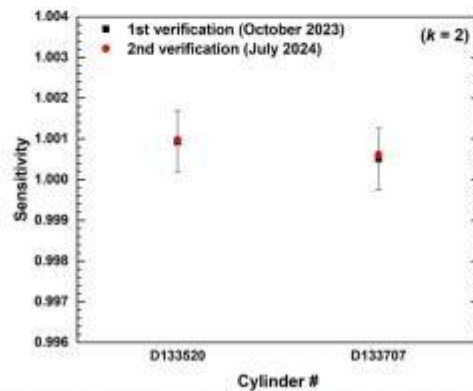

Figure 3. Verification results for CH₄ in synthetic air mixtures (error bars represent their preparation uncertainties).

h) Brief outline of any stability testing of the mixtures between the time they are prepared and the time they are shipped to the BIPM.

In order to check the any stability issues of transfer standards, new CH₄ in synthetic air standard (D207879) was prepared by gravimetric method and the sensitivity of new standard was compared with that of one of the transfer standards (D133520). Since the sensitivities of new and old standards agreed within their expanded uncertainties, the uncertainty due to instability was set to zero. The compared result was shown in Figure 4.

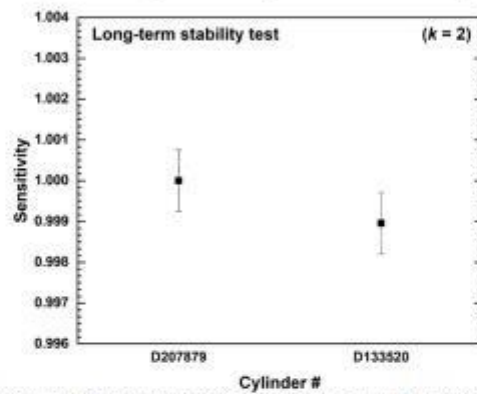

Figure 4. The result of long-term stability for new and old CH₄ in synthetic air standards (error bars represent their preparation uncertainties).

Laboratoire National de Métrologie et d'Essais (LNE)

Information to be submitted with mixtures

Key Comparison CCQM-K82.2023 Methane in Air at Ambient level (1800-2200) nmol/mol

Please complete this information sheet for each submitted standard and provide at least the information which is listed as mandatory below. Important: Failure to provide the mandatory information requested will exclude the standard from the set used to calculate the KCRV.

Institute	LNE			
Address	1 rue Gaston Boissier 75015 Paris			
Contact	Christophe Sutour			
Email	Christophe.sutour@lne.fr			
Telephone	+33 1 40 43 37 49			
Transfer Standards (cylinders) Information				
Standard #	ID (Serial Number)	Date of preparation	Pressure	(unit)
1	APE1126469	23/05/2023	130	bar
2	APE997315	25/05/2023	130	bar

Mandatory information

a) Purity table with uncertainties for the nominally pure N₂, O₂, Ar or scrubbed Air and CO₂ parent/balance gases

***** Pur\O2_ultrapur_ana_CH4.txt *****

Component	mol/mol	uncertainty
O2	0.9999994496	0.000001882
methane	0.000000004	0.000000001
H2O	0.000002500	0.000001443
CO2	0.000000250	0.000000144
CO	0.000000250	0.000000144
H2	0.000000500	0.000000289
N2	0.000002000	0.000001155

***** Pur\Ar_Bip_ana_CH4.txt *****

Component	mol/mol	uncertainty
Ar	0.9999998088	0.000000874
methane	0.000000012	0.000000005
H2O	0.000000100	0.000000058
CO2	0.000000125	0.000000072
CO	0.000000125	0.000000072
O2	0.000000050	0.000000029
N2	0.000001500	0.000000866

***** Pur\N2_Bip_filtre_ana_CH4.txt *****

Component	mol/mol	uncertainty
N2	0.9999999993	0.000000004
methane	0.000000004	0.000000004
H2O	0.000000001	0.000000000
O2	0.000000001	0.000000000
CO	0.000000001	0.000000000
CO2	0.000000001	0.000000000
H2	0.000000001	0.000000000
NO	0.000000000	0.000000000
NO2	0.000000000	0.000000000
SO2	0.000000000	0.000000000

b) Description of the traceability and measurement method for trace methane (critical impurity) in the pure parent/balance gases

The impurities of methane in pure oxygen, nitrogen and argon are analyzed by an Agilent 6890 GC-FID with a capillary column Carboxen 1010 (30 m, 0.53 mm, 30 μm) at 70°C. The sample loop is made with a part of carboxen 1010 which can be cooled down by a cryo trap (liquid nitrogen) to focus the sample.

Sample is flowing at 20 ml/min during 5 min at -170°C and heated to 280°C to perform the injection to the analytical column.

15 runs are performed and the last 3 runs are used to calculate the average and standard deviation of the methane peak area.

The GC-FID is calibrated between 0 to 50 nmol/mol using a CH₄/N₂ reference gas mixture diluted with a Sonimix 2106 generator (sonic nozzles).

c) Purity table for each of the final mixtures including the value and uncertainty of the methane amount fraction which arises from the

sum of trace methane that is a critical impurity in the pure parent/balance gases

Uncertainty budget of CH₄/AIR 0001 (APE1126469)

x	unit	value	u(x) k=1	Contribution %
Mass of premix	g	59.58107	1.6E-2	13.49
Amount of CH ₄	mol/mol	4.99947E-5	3.17E-8	81.00
Mass of N ₂	g	1222.982	0.019	0.03
N ₂ purity	Mol/mol	0.9999999997	1,00E-10	0.00
Mass of O ₂	g	393.10690	0.015	0.01
O ₂ purity	Mol/mol	0.99999996	1.882E-7	0.00
Mass of Arg	g	21.83927	0.015	0.01
Arg purity	Mol/mol	0.999999088	8.74E-8	0.00
CH ₄ molar mass	g/mol	16.04246	8.1E-4	0.00
N ₂ molar mass	g/mol	28.01348	9.9E-5	0.00
O ₂ molar mass	g/mol	31.9988	4.2E-4	0.00
Arg molar mass	g/mol	39.948	1.00E-3	0.00
CH ₄ in pur N ₂	Mol/mol	0.4E-9	0.4E-9	5.43
CH ₄ in pur O ₂	Mol/mol	0.4E-9	0.1E-9	0.03
CH ₄ in pur Arg	Mol/mol	1.2E-9	0.5E-9	0.00
<hr/>				
CH ₄	μmol/mol	1.8145	0.0026 (k=2)	

Uncertainty budget of CH₄/AIR 0002 (APE997315)

x	unit	value	u(x) k=1	Contribution %
Mass of premix	g	72.49510	0.014	7.50
Amount of CH ₄	mol/mol	4.99947E-5	3.17E-8	88.51
Mass of N ₂	g	1207.546	0.020	0.03
N ₂ purity	Mol/mol	0.9999999997	1,00E-10	0.00
Mass of O ₂	g	391.4977	0.015	0.01
O ₂ purity	Mol/mol	0.99999996	1.882E-7	0.00
Mass of Arg	g	21.71465	0.014	0.01
Arg purity	Mol/mol	0.999999088	8.74E-8	0.00
CH ₄ molar mass	g/mol	16.04246	8.1E-4	0.00
N ₂ molar mass	g/mol	28.01348	9.9E-5	0.00
O ₂ molar mass	g/mol	31.9988	4.2E-4	0.00
Arg molar mass	g/mol	39.948	1.00E-3	0.00
CH ₄ in pur N ₂	Mol/mol	0.4E-9	0.4E-9	3.91
CH ₄ in pur O ₂	Mol/mol	0.4E-9	0.1E-9	0.02
CH ₄ in pur Arg	Mol/mol	1.2E-9	0.5E-9	0.00
<hr/>				
CH ₄	μmol/mol	2.2131	0.0030 (k=2)	

d) Uncertainty budget for the final mixtures including gravimetric, stability, verification components and final combined uncertainty

CH₄/AIR 0001 (APE1126469)

x	unit	value	u(x) k=1	Contribution %
preparation	μmol/mol	1.8145	0.0013	46.52
verification	μmol/mol	1.81453	0.00137	53.45
prep-verification	μmol/mol	0.000030	0.000030	0.03
CH₄	μmol/mol	1.8145	0.0019 (k=2)	

CH₄/AIR 0002 (APE997315)

x	unit	value	u(x) k=1	Contribution %
preparation	μmol/mol	2.2131	0.0015	47.67
verification	μmol/mol	2.2130	0.0016	52.16
prep-verification	μmol/mol	0.00009	0.00009	0.17
CH₄	μmol/mol	2.2131	0.0022 (k=2)	

Additional non-mandatory information:

- e) Brief outline of the dilution series undertaken to produce the final mixtures
- f) Purity table with uncertainties for the nominally pure CH₄ parent gas
- g) Brief outline of the verification procedure applied to the final mixtures
- h) Brief outline of any stability testing of the mixtures between the time they are prepared and the time they are shipped to the BIPM.

Cylinders Composition

CH₄ amount fraction

Complete the highlighted cells below with the value of the amount fraction of methane measured in each cylinder, expressed in nmol/mol, the associated expanded uncertainty and its coverage factor k

Standard #	Cylinder ID	x_{CH_4}	$U(x_{CH_4})$	k
		nmol/mol	nmol/mol	
1	APE1126469	1814.5	2.6	2
2	APE997315	2213.1	3.0	2

Matrix Gas

Complete the cells below with the composition of the matrix gas

Indicate the amount fractions of the three major compounds

Compounds at trace levels may be indicated as well in the columns (other)

Indicate the unit in the cells

Compound	N ₂	O ₂	Ar	CO ₂	Other	Other
Standard #	%mol/mol	%mol/mol	%mol/mol	μmol/mol	(unit)	(unit)
1	78.1080	20.9587	0.9327	0.0054		
2	78.1461	20.9241	0.9296	0.0054		

Stability

LNE statement on 8/22/2024:

The stability measurements of CH₄/air RGMs is now completed and we confirm the values and uncertainties we submitted for the comparison.

National Institute of Metrology (NIM)

Information to be submitted with mixtures

Key Comparison CCQM-K82.2023

Methane in Air at Ambient level (1800-2200) nmol/mol

Please complete this information sheet for each submitted standard and provide at least the information which is listed as mandatory below. Important: Failure to provide the mandatory information requested will exclude the standard from the set used to calculate the KCRV.

Institute	National Institute of Metrology, China		
Address	Building 17, Room 217 18, Beisanhuandonglu, Chaoyang District, 100029, Beijing		
Contact	Honghong Wang & Zhe Bi		
Email	wanghh@nim.ac.cn	bizh@nim.ac.cn	
Telephone	86-10-64525345		
Transfer Standards (cylinders) Information			

Standard #	ID (Serial Number)	Date of preparation	Pressure	nmol/mol
1	L226018046	08/12/2023	14 Mpa	1812.7
2	L226014004	08/16/2023	14 Mpa	2202.1

Complete the cells below with the composition of the matrix gas Indicate the amount fractions of the three major compounds Compounds at trace levels may be indicated as well in the columns (other) Indicate the unit in the cells (unit)						
Compound	N ₂	O ₂	Ar	CO ₂	other	other
Standard #	mol/mol	mol/mol	mol/mol	(unit)	(unit)	(unit)
1	0.78123	0.20935	0.00941	0.00	0.00	0.00
2	0.78107	0.20963	0.00929	0.00	0.00	0.00

Mandatory information

a) Purity table with uncertainties for the nominally pure N₂, O₂, Ar or scrubbed Air and CO₂ parent/balance gases

Ar, pure, BIP	fraction	Std. u	Technique
Ar(Argon)	0.9999993	1.09E-07	/
CH ₄ (Methane)	4.00E-10	2.00E-10	CRDS
CO(Carbon monoxide)	5.00E-09	2.89E-09	GC-FID-Cat.**
CO ₂ (Carbon dioxide)	5.00E-09	2.89E-09	GC-FID-Cat.**
H ₂ (Hydrogen)	5.00E-09	2.89E-09	GC-PDHID
H ₂ O(Water)	2.50E-07	3.00E-08	CRDS
O ₂ (Oxygen)	1.50E-07	3.00E-08	O ₂ analyzer
N ₂ (Nitrogen)	3.20E-07	1.00E-07	GC-PDHID

O ₂ , pure, No. 13340434#	fraction	Std. u	Technique
Ar(Argon)	5.00E-06	2.89E-06	Product Spec.*
CH ₄ (Methane)	5.10E-10	5.10E-10	CRDS
CO(Carbon monoxide)	5.00E-09	2.89E-09	GC-FID-Cat.**
CO ₂ (Carbon dioxide)	5.00E-09	2.89E-09	GC-FID-Cat.**
H ₂ (Hydrogen)	1.00E-08	5.77E-09	GC-PDHID
H ₂ O(Water)	5.00E-07	2.89E-07	CRDS
O ₂ (Oxygen)	0.9999895	3.27E-06	/
N ₂ (Nitrogen)	5.00E-06	1.50E-06	GC-PDHID

N ₂ , pure, BIP	fraction	Std. u	Technique
Ar(Argon)	6.00E-06	2.89E-06	GC-PDHID
CH ₄ (Methane)	4.50E-10	4.50E-10	CRDS
CO(Carbon monoxide)	5.00E-09	2.89E-09	GC-FID-Cat.**
CO ₂ (Carbon dioxide)	9.00E-08	2.89E-09	GC-FID-Cat.**
H ₂ (Hydrogen)	1.00E-08	2.89E-09	GC-PDHID
H ₂ O(Water)	1.00E-07	5.77E-08	CRDS
O ₂ (Oxygen)	2.60E-07	7.80E-08	Product Spec.*
N ₂ (Nitrogen)	0.999994	2.89E-06	/

* Product Spec., data was from the product specification provided by the manufacturer.

** GC-FID-Cat., GC-FID with methanator. CO and CO₂ were not detected, and thereby half of detection limit was taken as their concentration.

b) Description of the traceability and measurement method for trace methane (critical impurity) in the pure parent/balance gases;

The standard addition method combined with CRDS were used to analyze the trace methane in parent gases. The reference standards are generated using the different parent gases under test as the diluent spiked with a known amount fraction of methane. The dilution diagram for the dynamic measurement of the trace methane content of parent gases is shown in Fig. 1. An advantage of this method is that matrix effects are reduced as the calibration function takes account of any impurities in the parent gas under test.

Also, measurements are performed away from the detection limit of the instrument. This technique is dependent on the analyzer calibration at absolute zero.

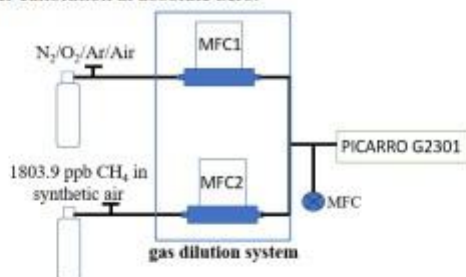

Fig. 1. Dilution diagram for the dynamic measurement of the trace methane content of parent gases.

Table 1. Dilution results and CRDS indicating value (nmol/mol) of different parent gases spiking with a known amount fraction of the methane

Dilution ratio	Calculated concentration (nmol/mol)	CRDS indicating value-N ₂ dilution	CRDS indicating value-O ₂ dilution	CRDS indicating value-Ar dilution	CRDS indicating value-Air dilution
2000: 0	0.0900	0.4433	0.5683	0.3857	0.4850
2000: 1	0.9015	1.3696	1.5984	1.2492	1.4124
2000: 2	1.8021	2.3224	2.2991	2.1156	2.2169
2000: 3	2.7018	3.1933	3.1770	2.9917	3.0862
2000: 4	3.6006	4.0821	4.0955	3.8850	3.9859
2000: 5	4.4985	5.0342	4.9808	4.6916	4.8000

As shown in Table 1, by adding known concentration of methane to different parent gases containing the preexisting methane, the concentration of the preexisting methane can be quantified, being free from the matrix effects or recovery rates. The SAM regression equation can be expressed as $y=ax+b$, where "a" is the slope of the SAM calibration curve; "b" is the value of the intercept of the SAM curve on the y axis, reflecting the area or height of a preexisting compound in a matrix. When y equals zero, $x=-b/a$, which shows the negative concentration of the preexisting methane in the tested parent gases. The correlation coefficients or coefficients of determination should be greater than 0.99 (within appropriate calibration range) for reliable measurements of the target compounds. Then we use the equation $x=-b/a$ to determine the quantity of methane in parent gases. The SAM regression equation of N₂, O₂ and Ar as diluent were $y = 1.015x + 0.4562$, $y = 0.9950x + 0.50377$ and $y = 0.9627x + 0.3860$. Therefore, the methane concentrations in parent gas N₂, O₂ and Ar were calculated to be 0.45 nmol/mol, 0.51 nmol/mol and 0.40 nmol/mol. Finally, we use synthetic air as the diluent gas spiked with the same known amount fraction of methane to get the SAM curve. The methane concentration of synthetic air was calculated to be 0.51 nmol/mol from the regression equation $y = 0.9674x + 0.4969$. This is almost consistency with the trace methane concentration of parent gases.

c) Purity table for each of the final mixtures including the value and uncertainty of the methane amount fraction which arises from the sum of trace methane that is a critical impurity in the pure parent/balance gases

Cyl. No. L224018046	fraction, $\mu\text{mol/mol}$	std u_{grav} , $\mu\text{mol/mol}$	Exp. U_{grav}
Ar(Argon)	9.4200E-03	2.87E-06	5.74E-06
CH ₄ (Methane)	1.8127E-06	4.31E-10	8.62E-10
CO(Carbon monoxide)	5.0000E-09	2.26E-08	4.51E-08
CO ₂ (Carbon dioxide)	7.1404E-08	2.26E-08	4.51E-08
H ₂ (Hydrogen)	1.0000E-08	2.26E-08	4.52E-08
H ₂ O(Water)	9.0944E-08	7.44E-08	1.49E-07
O ₂ (Oxygen)	2.0935E-01	3.93E-06	7.87E-06
N ₂ (Nitrogen)	7.8122E-01	4.59E-06	9.18E-06

Cyl. No. L224014004	fraction, $\mu\text{mol/mol}$	std u_{grav} , $\mu\text{mol/mol}$	Exp. U_{grav}
Ar(Argon)	9.3000E-03	2.62E-06	5.24E-06
CH ₄ (Methane)	2.2021E-06	4.40E-10	8.80E-10
CO(Carbon monoxide)	5.0000E-09	2.24E-09	4.47E-09
CO ₂ (Carbon dioxide)	7.1390E-08	2.24E-08	4.47E-08
H ₂ (Hydrogen)	1.0000E-08	2.24E-09	4.48E-09
H ₂ O(Water)	9.0913E-08	7.42E-09	1.48E-08
O ₂ (Oxygen)	2.0963E-01	4.21E-06	8.41E-06
N ₂ (Nitrogen)	7.8107E-01	4.74E-06	9.47E-06

d) Uncertainty budget for the final mixtures including gravimetric, stability, verification components and final combined uncertainty

The uncertainty for the final mixtures contains the following components:

- 1) Gravimetric preparation (u_{grav}): a. Purity analysis of CH₄ and of other parent gases (N₂ O₂ and Ar); b. weighing uncertainty; c. atomic weight uncertainties
- 2) Stability uncertainty (u_{stab}): Stability-induced uncertainty was taken as 0.
- 3) Verification uncertainty (u_{ver}): a standard uncertainty of verification is 0.2 nmol/mol

Therefore, the final combined uncertainty was $u_c = \sqrt{u_{\text{grav}}^2 + u_{\text{stab}}^2 + u_{\text{ver}}^2}$

Additional non-mandatory information:

e) Brief outline of the dilution series undertaken to produce the final mixtures

The standard gas mixtures of methane in synthetic air were prepared by using gravimetric method according to ISO6142:2001, and the parent gases were nitrogen, oxygen, argon and methane of high purity. The flow chart below showed dilution from pure gases to the final gas mixtures of CH₄/air.

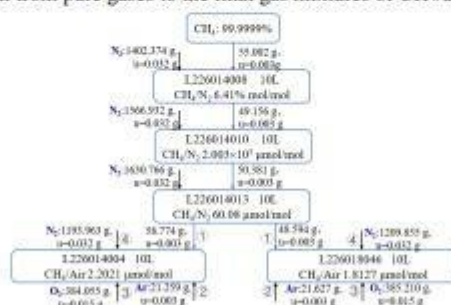

Figure 2. Dilution scheme from pure gases to CH₄/syn air

Mass comparator with capacity of 26.0 kg and resolution of 1mg was provided by Mettler Toledo. Temperature and relative humidity in balance room were controlled at 22°C±1°C and 45%RH±5%RH, respectively. Tare cylinder and substitution method were used during weighing of cylinder in order to cancel buoyancy effect.

Fig. 1 showed that standard uncertainty to the mass of added parent gas into the target cylinder was estimated as 0.001g-0.004 g when the added gas was around 50 g. By 4-step dilutions, around 2ppm methane in synthetic air could be achieved from the pure gases.

f) Purity table with uncertainties for the nominally pure CH₄ parent gas

CH ₄ pure, No. 47588#	fraction	Std. u	Technique
Ar(Argon)	3.00E-08	2.00E-08	GC-PDHID
CO(Carbon monoxide)	3.00E-08	1.00E-08	GC-PDHID
CO ₂ (Carbon dioxide)	9.00E-08	4.00E-08	GC-PDHID
H ₂ (Hydrogen)	6.00E-08	3.00E-08	GC-PDHID
H ₂ O(Water)	2.70E-07	1.60E-07	Portable trace moisture meter
O ₂ (Oxygen)	2.00E-08	2.00E-08	GC-PDHID
N ₂ (Nitrogen)	1.70E-07	1.00E-08	GC-PDHID
CH ₄ (Methane)	0.9999993	1.71E-07	/

g) Brief outline of the verification procedure applied to the final mixtures

A Picarro G2301 Cavity ring-down spectrometer was used to analyze the amount fraction of CH₄ in six newly prepared mixtures and an old mixture (reference mixture). The analyser response to a reference mixture

was then recorded for a ten minutes period followed by the other six samples for the same time. This sequence was repeated four times. The amount fractions of six newly prepared mixtures were then determined by multiplying the ratio of the analyser response to each mixture and the reference mixture with the amount fraction of the reference mixture. These measurements were used to validate the internal consistency and the gravimetric amount fractions submitted.

Cylinders were maintained at a laboratory temperature of (23 ± 2) °C throughout the period of analysis. Samples were introduced into the analyser at atmospheric pressure (excess flow was passed to vent) by using the gas regulator. Sample gas flow rate was around 350 mL/min. Measurement of each sample took ten minutes, and data during last 1 minutes were collected and averaged.

Verification was carried out every four days, and the results showed a standard uncertainty (u_{ver}) of 0.2 nmol/mol.

h) Brief outline of any stability testing of the mixtures between the time they are prepared and the time they are shipped to the BIPM.

Stability of newly prepared cylinders was checked against the old mixture by using CRDS. The above measurement procedure was carried out every four days after the samples were prepared. Until to the time samples are shipped to the BIPM, the measurement was conducted five times. In the long-term stability test, differences in gravimetric and verified mole fraction of CH₄ were less than 0.008%. No instability was found in the results. Stability-induced uncertainty (u_{stab}) was taken as 0.

Cylinders Composition

CH₄ amount fraction

Complete the highlighted cells below with the value of the amount fraction of methane measured in each cylinder, expressed in nmol/mol, the associated expanded uncertainty and its coverage factor k

Standard #	Cylinder ID	x_{CH_4}	$U(x_{\text{CH}_4})$	k
		nmol/mol	nmol/mol	
1	L226018046	1812.7	1.00	2.00
2	L226014004	2202.1	1.20	2.00

Matrix Gas

Complete the cells below with the composition of the matrix gas

Indicate the amount fractions of the three major compounds

Compounds at trace levels may be indicated as well in the columns (other)

Indicate the unit in the cells

Compound	N ₂	O ₂	Ar	CO ₂	Other	Other
Standard #	mol/mol	mol/mol	mol/mol	(unit)	(unit)	(unit)
1	0.78123	0.20935	0.00941	0.00	0.00	0.00
2	0.78107	0.20963	0.00929	0.00	0.00	0.00

Stability

NIM statement on 9/24/2024:

We have completed the stability measurements you intended to undertake and confirm the values and uncertainties you submitted for the comparison.

National Institute of Metrology of Thailand (NIMT)

Information to be submitted with mixtures
 Key Comparison CCQM-K82.2023
 Methane in Air at Ambient level (1800-2200) nmol/mol

Please complete this information sheet for each submitted standard and provide at least the information which is listed as mandatory below. Important: Failure to provide the mandatory information requested will exclude the standard from the set used to calculate the KCRV.

Institute	National Institute of Metrology (Thailand)
Address	3/4-5 Moo 3, Klong 5, Klong Luang, Pathumthani 12120 Thailand
Contact	Mr. Arnuttachai Wongjuk
Email	arnuttachai@nimt.or.th
Telephone	+66 (0) 2 026 5400 ex. 5304
Transfer Standards (cylinders) Information	

Standard #	ID (Serial Number)	Date of preparation	Pressure	(unit)
1	D094433	16/02/2023	105	bar(g)
2	D094436	20/02/2023	100	bar(g)

Authorship

Arnuttachai Wongjuk, Soponrat Rattanasombat, Ratirat Sinweeruthai

Mandatory information

a) Purity table with uncertainties for the nominally pure N₂, O₂, Ar or scrubbed Air and CO₂ parent/balance gases

Table a-1: Purity table for pure N₂

Component	Amount fraction ($\mu\text{mol/mol}$)	Detector	Distribution	Applied Amount fraction ($\mu\text{mol/mol}$)	standard uncertainty ($\mu\text{mol/mol}$)	
O ₂	0.04	CRDS	Rectangular	0.04	0.01	
Ar	15.11	GC/PDHID	Normal	15.11	0.16	
CO	0.10	GC/FID*	Rectangular	0.10	0.02	
CO ₂	0.28	GC/FID*	Rectangular	0.28	0.03	
CH ₄	<0.005	GC/FID	Rectangular	0.002	0.001	
H ₂ O	0.63	CRDS	Rectangular	0.63	0.36	
			impurities	16.16	0.40	
			N ₂ purity	999983.8	0.79	k=2

*GC/FID with methanizer

Table a-2: Purity table for pure O₂

Component	Amount fraction ($\mu\text{mol/mol}$)	Detector	Distribution	Applied Amount fraction ($\mu\text{mol/mol}$)	standard uncertainty ($\mu\text{mol/mol}$)	
H ₂	<0.05	GC/PDHID	Rectangular	0.02	0.014	
N ₂	<0.02	GC/PDHID	Rectangular	0.009	0.005	
CO	<0.01	GC/PDHID	Rectangular	0.006	0.003	
CO ₂	1.61	GC/FID*	Normal	1.61	0.12	
Ar	<1.45	GC/TCD	Rectangular	0.725	0.42	
CH ₄	<0.005	GC/FID	Rectangular	0.002	0.001	
H ₂ O	4.32	CRDS	Rectangular	4.32	2.5	
			impurities	6.70	2.53	
			O ₂ purity	999993.3	5.07	k=2

*GC-FID with Methanizer

Table a-3: Purity table for pure Ar

Component	Amount fraction ($\mu\text{mol/mol}$)	Detector	Distribution	Applied Amount fraction ($\mu\text{mol/mol}$)	standard uncertainty ($\mu\text{mol/mol}$)	
O ₂	0.73	CRDS	Rectangular	0.73	0.21	
N ₂	<0.005	GC/PDHID	Rectangular	0.002	0.001	
CO	<0.11	GC/FID*	Rectangular	0.05	0.03	
CO ₂	<0.1	GC/FID*	Rectangular	0.04	0.02	
CH ₄	<0.005	GC/FID	Rectangular	0.002	0.001	
H ₂ O	1.11	CRDS	Rectangular	1.11	0.64	
			impurities	1.93	0.67	
			Ar purity	999998.1	1.35	k=2

*GC-FID with Methanizer

Page 2 of 9

CCQM-K82.2023

97/192

Table a-4: Purity table for pure CO₂

Component	Amount fraction ($\mu\text{mol/mol}$)	Detector	Distribution	Applied Amount fraction ($\mu\text{mol/mol}$)	standard uncertainty ($\mu\text{mol/mol}$)
O ₂	0.96	GC/PDHID	Rectangular	0.96	0.007
N ₂	4.95	GC/PDHID	Rectangular	4.950	0.073
CO	<0.07	GC/PDHID	Rectangular	0.033	0.019
CH ₄	0.21	GC/FID	Rectangular	0.207	0.01
C ₂ H ₄	<0.005	GC/FID	Rectangular	0.674	0.033
H ₂ O	7.06	Dew Point Meter	Rectangular	7.06	4.1
impurities				13.88	4.08
CO ₂ purity				999986.1	8.15

k=2

b) Description of the traceability and measurement method for trace methane (critical impurity) in the pure parent/balance gases;

The assigned value of trace methane in the balance gases was determined by using one-point calibration against another PRM traceable to NIMT standard. The NIMT standard composition and the analytical conditions for analysis of trace methane are presented in the following.

NIMT standard composition

Components	Amount fraction ($\mu\text{mol/mol}$)
H ₂	10.06
CO ₂	10.26
N ₂ O	10.11
O ₂	10.33
N ₂	10.24
CH ₄	10.19
CO	10.08
He	Balance
Uncertainty	1.0%
Cylinder No.	PRM210111
Due date.	10/5/2025

Analytical condition for trace methane analysis

CH₄	GC-FID
Column	Hayesep Q
Carrier flow	25 mL/min
Oven temperature	35 °C
Detector temperature	250 °C
H ₂ flow	40 mL/min
Air flow	400 mL/min
Sample flow	50 mL/min
Sample loop	2 mL

c) Purity table for each of the final mixtures including the value and uncertainty of the methane amount fraction which arises from the sum of trace methane that is a critical impurity in the pure parent/balance gases

Purity table for 1.785 µmol/mol
Cylinder ID: D094433

Component	Gravimetric value	Gravimetric uncertainty $U(x_i), k=2$
CH ₄	1785.1 nmol/mol	2.1 nmol/mol
CO ₂	370.82 µmol/mol	0.11 µmol/mol
Ar	9134.7 µmol/mol	1.2 µmol/mol
O ₂	21.007 cmol/mol	0.002 cmol/mol
N ₂	78.042 cmol/mol	0.006 cmol/mol

Purity table for 2.185 µmol/mol
Cylinder ID: D094436

Component	Gravimetric value	Gravimetric uncertainty $U(x_i), k=2$
CH ₄	2184.9 nmol/mol	1.8 nmol/mol
CO ₂	365.46 µmol/mol	0.10 µmol/mol
Ar	9100.2 µmol/mol	1.2 µmol/mol
O ₂	20.927 cmol/mol	0.002 cmol/mol
N ₂	78.126 cmol/mol	0.005 cmol/mol

Uncertainty budget for the mole fraction of CH₄ in the final mixture

Cylinder ID. D094433

Quantity	Value	Standard Uncertainty	Distribution	Sensitivity Coefficient	Uncertainty Contribution
ρ_{comp1}	9.20E-05 mol	0.058 %rel	Normal	1	5.80E-02 %rel
ρ_{comp2}	1.91E-02 mol	0.012 %rel	Normal	1	1.20E-02 %rel
ρ_{comp3}	1.08E+01 mol	0.0003 %rel	Normal	1	2.64E-04 %rel
ρ_{comp4}	4.71E-01 mol	0.003 %rel	Normal	1	2.74E-03 %rel
ρ_{comp5}	4.02E+01 mol	0.0002 %rel	Normal	1	1.52E-04 %rel
m_{comp1}	51.46 g	4.10E-03 %rel	Normal	1	4.10E-03 %rel
(Samp-Tare) _{empty}	-8.11 g	0.872 mg			
(Samp-Tare) _{comp1}	43.35 g	0.707 mg			
U_{in}	0.00 g	1.789 mg			
U_{exp}	0.00 g	0.000 mg			
mol	0.00 mol	0.000 mol			
m_{comp2}	37.50 g	5.50E-03 %rel	Normal	1	5.50E-03 %rel
(Samp-Tare) _{empty}	43.35 g	0.707 mg			
(Samp-Tare) _{comp1}	80.84 g	0.748 mg			
U_{in}	0.00 g	1.789 mg			
U_{exp}	0.00 g	0.000 mg			
mol	0.02 mol	0.000 mol			
m_{comp3}	346.29 g	5.92E-04 %rel	Normal	1	5.92E-04 %rel
(Samp-Tare) _{empty}	80.84 g	0.748 mg			
(Samp-Tare) _{comp1}	427.13 g	0.663 mg			
U_{in}	0.00 g	1.789 mg			
U_{exp}	0.00 g	0.000 mg			
mol	10.82 mol	0.000 mol			
m_{comp4}	1056.95 g	1.57E-03 %rel	Normal	1	1.48E-03 %rel
(Samp-Tare) _{empty}	427.13 g	0.663 mg			
(Samp-Tare) _{comp1}	1484.08 g	0.812 mg			
U_{in}	0.00 g	1.789 mg			
U_{exp}	0.00 g	16.414 mg			
mol	40.20 mol	0.001 mol			
MW_{comp1}	16.043 g/mol	8.18E-03 %rel	Normal	1	8.18E-03 %rel
MW_{comp2}	44.009 g/mol	3.26E-03 %rel	Normal	1	3.26E-03 %rel
MW_{comp3}	31.999 g/mol	2.67E-03 %rel	Normal	1	2.67E-03 %rel
MW_{comp4}	28.014 g/mol	3.50E-03 %rel	Normal	1	3.50E-03 %rel
MW_{comp5}	39.948 g/mol	1.45E-03 %rel	Normal	1	1.45E-03 %rel
					0.105
CH ₄	1.7851 $\mu\text{mol/mol}$	0.0010 $\mu\text{mol/mol}$			0.059 %rel
CO ₂	370.82 $\mu\text{mol/mol}$	0.051 $\mu\text{mol/mol}$			0.014 %rel
Ar	9134.7 $\mu\text{mol/mol}$	0.29 $\mu\text{mol/mol}$			0.003 %rel
O ₂	21.007 cmol/mol	0.001 cmol/mol			0.003 %rel
N ₂	78.042 cmol/mol	0.003 cmol/mol			0.004 %rel

Cylinder ID. D094436

Quantity	Value	Standard Uncertainty	Distribution	Sensitivity Coefficient	Uncertainty Contribution
n_{comp1}	1.08E-04 mol	3.96E-02 %rel	Normal	1	3.96E-02 %rel
n_{comp2}	1.80E-02 mol	1.17E-02 %rel	Normal	1	1.17E-02 %rel
n_{comp3}	1.03E+01 mol	2.64E-04 %rel	Normal	1	2.64E-04 %rel
n_{comp4}	3.84E+01 mol	1.74E-04 %rel	Normal	1	1.74E-04 %rel
n_{comp5}	3.84E+01 mol	1.74E-04 %rel	Normal	1	1.74E-04 %rel
n_{comp6}	4.48E-01 mol	2.61E-03 %rel	Normal	1	2.61E-03 %rel
m_{comp1}	60.18 g	3.57E-03 %rel	Normal	1	3.57E-03 %rel
$(\text{Samp-Tare})_{\text{empty}}$	-18.47 g	0.872 mg			
$(\text{Samp-Tare})_{\text{comp1}}$	41.70 g	0.812 mg			
U_{in}	0.00 g	1.789 mg			
U_{exp}	0.00 g	0.000 mg			
mol	0.00 mol	0.000 mol			
m_{comp2}	35.66 g	5.68E-03 %rel	Normal	1	5.67E-03 %rel
$(\text{Samp-Tare})_{\text{empty}}$	41.70 g	0.812 mg			
$(\text{Samp-Tare})_{\text{comp1}}$	77.36 g	0.490 mg			
U_{in}	0.00 g	1.789 mg			
U_{exp}	0.00 g	0.000 mg			
mol	0.02 mol	0.000 mol			
m_{comp3}	329.56 g	5.90E-04 %rel	Normal	1	5.90E-04 %rel
$(\text{Samp-Tare})_{\text{empty}}$	77.36 g	0.490 mg			
$(\text{Samp-Tare})_{\text{comp1}}$	406.91 g	0.583 mg			
U_{in}	0.00 g	1.789 mg			
U_{exp}	0.00 g	0.000 mg			
mol	10.30 mol	0.000 mol			
m_{comp4}	708.57 g	2.92E-04 %rel	Normal	1	1.56E-03 %rel
$(\text{Samp-Tare})_{\text{empty}}$	406.91 g	0.583 mg			
$(\text{Samp-Tare})_{\text{comp1}}$	1115.49 g	0.860 mg			
U_{in}	0.00 g	1.789 mg			
U_{exp}	0.00 g	0.000 mg			
mol	38.45 mol	0.001 mol			
m_{comp5}	291.36 g	5.68E-03 %rel	Normal	1	1.56E-03 %rel
$(\text{Samp-Tare})_{\text{empty}}$	1115.49 g	0.860 mg			
$(\text{Samp-Tare})_{\text{comp1}}$	1406.85 g	0.735 mg			
U_{in}	0.00 g	1.789 mg			
U_{exp}	0.00 g	16.414 mg			
mol	38.45 mol	0.001 mol			
MW_{comp1}	16.043 g/mol	8.18E-03 %rel	Normal	1	8.18E-03 %rel
MW_{comp2}	44.009 g/mol	3.26E-03 %rel	Normal	1	3.26E-03 %rel
MW_{comp3}	31.999 g/mol	2.67E-03 %rel	Normal	1	2.67E-03 %rel
MW_{comp4}	28.014 g/mol	3.50E-03 %rel	Normal	1	3.50E-03 %rel
MW_{comp5}	28.014 g/mol	3.50E-03 %rel	Normal	1	3.50E-03 %rel
MW_{comp6}	39.948 g/mol	1.45E-03 %rel	Normal	1	1.45E-03 %rel
CH4	2.1849 $\mu\text{mol/mol}$	0.0009 $\mu\text{mol/mol}$			0.04 %rel
CO2	365.46 $\mu\text{mol/mol}$	0.0489 $\mu\text{mol/mol}$			0.01 %rel
Ar	9100.2 $\mu\text{mol/mol}$	0.5833 $\mu\text{mol/mol}$			0.01 %rel
O2	20.927 cmol/mol	0.0006 cmol/mol			0.00 %rel
N2	78.126 cmol/mol	0.0030 cmol/mol			0.00 %rel

d) Uncertainty budget for the final mixtures including gravimetric, stability, verification components and final combined uncertainty

The assigned value of gas content in final gas mixture was performed by gravimetric method in accordance with the requirements of ISO 6142-1 and verified the composition by comparison method in accordance with the requirements of ISO 12963.

Cylinder ID. D094433

Uncertainty source	Estimate (absolute unit)	Standard uncertainty (%relative)	Contribution to standard uncertainty (%relative)
- The Gravimetric gas mixture, (X_i)	1.7851	0.059	0.059
- The standard gas mixture, (X_{ref})	1.7853	0.059	0.059
- Response of CRM, $u(Y_{ref})$	115.79	0.024	0.024
- Response of sample, $u(Y_c)$	115.78	0.010	0.010
- Analytical content between cycle, $u(x_{\text{lab}})$	-	0.017	0.017
- Measurement Bias, $u(X_S)$	0.00	0.002	0.002
Stability, $u(X_{stab})$ 0.1%	0.0018	0.10	0.10
Analytical content of sample, (X_c)	1.7852	Combined uncertainty	0.14
Expanded uncertainty ($k = 2$), %relative			0.28

Cylinder ID. D094436

Uncertainty source	Estimate (absolute unit)	Standard uncertainty (%relative)	Contribution to standard uncertainty (%relative)
- The Gravimetric gas mixture, (X_i)	2.1849	0.041	0.041
- The standard gas mixture, (X_{ref})	2.1853	0.044	0.044
- Response of CRM, $u(Y_{ref})$	141.66	0.041	0.041
- Response of sample, $u(Y_c)$	141.66	0.016	0.016
- Analytical content between cycle, $u(x_{\text{lab}})$	-	0.029	0.029
- Measurement Bias, $u(X_S)$	0.01	0.007	0.007
Stability, $u(X_{stab})$ 0.1%	0.0022	0.10	0.10
Analytical content of sample, (X_c)	2.1852	Combined uncertainty	0.13
Expanded uncertainty ($k = 2$), %relative			0.26

Additional non-mandatory information:

e) Brief outline of the dilution series undertaken to produce the final mixtures

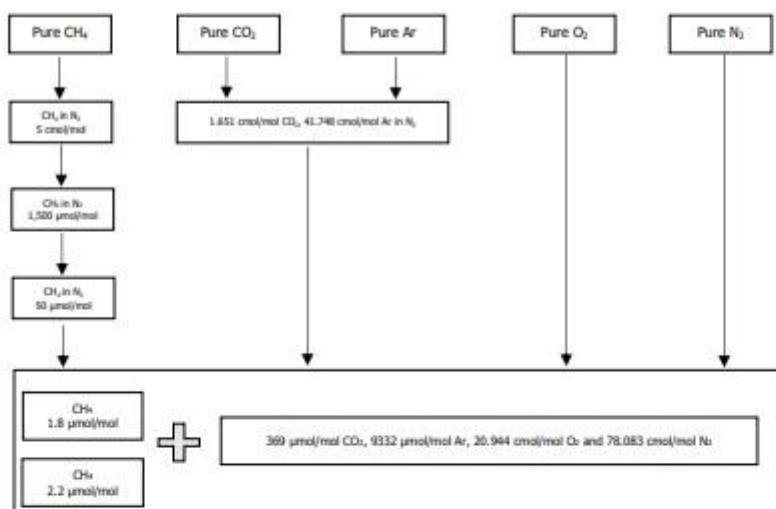
f) Purity table with uncertainties for the nominally pure CH₄ parent gasTable f-1: Purity table for CH₄

Component	Amount fraction (μmol/mol)	Detector	Distribution	Applied Amount fraction (μmol/mol)	standard uncertainty (μmol/mol)
H ₂	<0.01	GC/PDHID	Rectangular	0.006	0.003
N ₂	0.54	GC/PDHID	Normal	0.54	0.006
CO	<0.06	GC/PDHID	Rectangular	0.029	0.017
O ₂	0.55	GC/PDHID	Normal	0.55	0.006
CO ₂	<0.58	GC/FID*	Rectangular	0.29	0.17
C ₃ H ₈	0.28	GC/FID	Normal	0.28	0.010
THC	2.81	GC/FID	Normal	2.8	0.10
H ₂ O	1.00	Dew Point Meter	Rectangular	1.0	0.58
			impurities	5.51	0.61
			CH ₄ purity	999994.5	1.23

*GC-FID with Methanizer

k=2

g) Brief outline of the verification procedure applied to the final mixtures

The assigned value (mole fraction) of methane was determined in compliance with ISO 6142-1:2015 using the gravimetric method. The mole fraction of methane was verified by Gas Chromatograph with Flame Ionization Detector (GC-FID) using one-point calibration against another PRM traceable to NIMT standard. Analytical conditions for gas analysis of methane are presented in the following.

CH₄	GC-FID
Column	Hayesep Q
Carrier flow	25 mL/min
Oven temperature	35 °C
Detector temperature	250 °C
H ₂ flow	40 mL/min
Air flow	400 mL/min
Sample flow	50 mL/min
Sample loop	5 mL

h) Brief outline of any stability testing of the mixtures between the time they are prepared and the time they are shipped to the BIPM.

NIMT prepared gravimetrically ambient-level methane in air standard as of 16 February 2023 and verified the difference mole fraction from gravimetric by prepared another standard as of 8 march 2023 and 16 August 2023 respectively. In the long-term stability test, differences in gravimetric and verified mole fraction of methane was less than 0.1 %. There results predict shelf life for primary standard gas mixture of ambient-level methane in air are stable over 2 years.

Cylinders Composition

CH₄ amount fraction

Complete the highlighted cells below with the value of the amount fraction of methane measured in each cylinder, expressed in nmol/mol, the associated expanded uncertainty and its coverage factor k

Standard #	Cylinder ID	x_{CH_4}	$U(x_{\text{CH}_4})$	k
		nmol/mol	nmol/mol	
1	D094433	1785.08	5.00	2.00
2	D094436	2184.90	5.68	2.00

Matrix Gas

Complete the cells below with the composition of the matrix gas

Indicate the amount fractions of the three major compounds

Compounds at trace levels may be indicated as well in the columns (other)

Indicate the unit in the cells

Compound	N ₂	O ₂	Ar	CO ₂	Other	Other
Standard #	cmol/mol	cmol/mol	μmol/mol	μmol/mol	(unit)	(unit)
1	78.04	21.01	9134.67	370.82		
2	78.13	20.93	9100.20	365.46		

Stability

10/16/2024

I would like to formally confirm the values and associated uncertainties that I previously submitted for comparison.

National Institute of Standards and Technology (NIST)

Information to be submitted with mixtures

Key Comparison CCQM-K82.2023 Methane in Air at Ambient level (1800-2200) nmol/mol

Please complete this information sheet for each submitted standard and provide at least the information which is listed as mandatory below. Important: Failure to provide the mandatory information requested will exclude the standard from the set used to calculate the KCRV.

Institute	National Institute of Standards and Technology (NIST)			
Address	100 Bureau Drive, Stop 8393 Gaithersburg, MD 20899-8393, USA			
Contact	Christina Cecelski; Jennifer Carney			
Email	christina.cecelski@nist.gov; jennifer.carney@nist.gov			
Telephone	+1(301)975-5185			
Transfer Standards (cylinders) Information				
Standard #	ID (Serial Number)	Date of preparation	Pressure	(unit)
1	FF68037	01 Sep 2023	1150 (7.9)	psi (MPa)
2	FF68033	21 Aug 2023	1300 (9.0)	psi (MPa)

Mandatory information

a) Purity table with uncertainties for the nominally pure N₂, O₂, Ar or scrubbed Air and CO₂ parent/balance gases

Table 1. Purity assay of synthetic air 2286493Y, used for preparation of FF68037 and FF68033.

Component	Amount fraction (mol/mol)	Standard uncertainty (mol/mol)
N ₂ (difference)	0.780 687 665 76	0.000 040 811 55
CH ₄	0.000 000 012 94	0.000 000 000 44
Ar	0.009 380	0.000 020
O ₂	0.209 49	0.000 035
CO ₂	0.000 441 00	0.000 000 16

Table 2. Gravimetric amount fractions of parent mixture FF4241, used for preparation of FF68037.

Component	Amount fraction (mol/mol)	Standard uncertainty (mol/mol)
CH ₄	0.000 076 167	0.000 000 019
N ₂	0.780 882 149	0.000 077 975
Ar	0.009 477	0.000 011
O ₂	0.209 126	0.000 050
CO ₂	0.000 438 51	0.000 000 22

Table 3. Gravimetric amount fractions of parent mixture FF4255, used for preparation of FF68033.

Component	Amount fraction (mol/mol)	Standard uncertainty (mol/mol)
CH ₄	0.000 105 014	0.000 000 023
N ₂	0.780 838 458	0.000 064 287
Ar	0.009 392	0.000 019
O ₂	0.209 249	0.000 036
CO ₂	0.000 416 15	0.000 000 15

b) Description of the traceability and measurement method for trace methane (critical impurity) in the pure parent/balance gases

Trace methane in the balance air, 2286493Y, was value assigned by cavity ring-down spectroscopy (CRDS) (Tiger Optics, model LaserTrace3). Due to the limited availability of gas standards containing trace-level methane, value assignment was determined by dilution of a NIST Standard Reference Material (SRM) [1] containing nominal 1 μmol/mol methane in air (Table 4). An Environics Series 4040 gas dilution system was used to dilute the SRM with ultra-high purity (UHP) nitrogen, cylinder TWO7-409050. Sample and dilution flows were varied to produce a series

of dilution setpoints ranging from (1 to 20) nmol/mol, while maintaining a constant total flow of 4900 mL/min.

Table 4. NIST methane in air standard used for value assignment to balance air 2286493Y. Uncertainty is expressed at approximately 95 % confidence ($k = 2$).

SRM number	Sample number	Cylinder number	Certified amount fraction ($\mu\text{mol/mol}$)
1658a	12-2-E	CLM006912	1.19 ± 0.01

A calibration curve was determined from the dilution data using a second-order generalized least-squares regression program (GenLine) compliant with ISO 6143 [2,3]. The average instrument response and uncertainty were plotted on the x-axis, and the calculated amount fraction and uncertainty were plotted on the y-axis, for each dilution setpoint (Figure 1). The resulting regression equation was then used to predict the methane amount fraction in the balance gas, based on its measured instrument response. The regression equation and corresponding amount fraction value are included in Table 5.

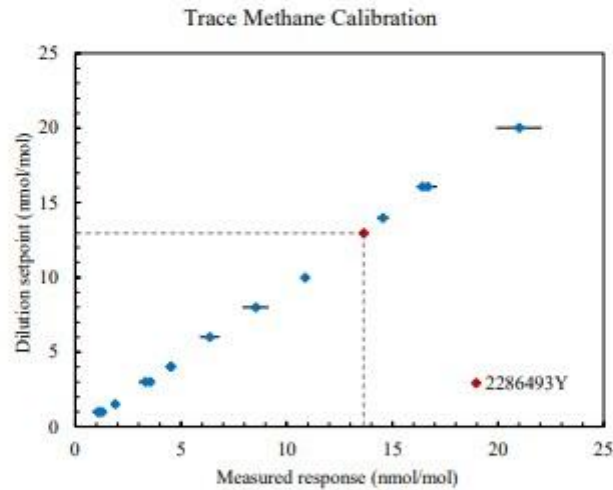

Figure 1. Calibration curve used for trace methane value assignment to balance air cylinder 2286493Y. Blue diamonds represent the amount fraction and corresponding instrument response for each dilution setpoint. The red diamond indicates the measured value and predicted amount fraction for the balance air cylinder. Error bars represent associated expanded ($k = 2$) uncertainties and are displayed for both the x and y axis, but in many cases are too small to be seen on the plot.

Table 5. Regression coefficients (b) and predicted amount fraction (y) for the trace methane in balance air cylinder 2286493Y, with associated standard uncertainties.

$y = b_0 + b_1x + b_2x^2$			y (nmol/mol)
b_0	b_1	b_2	
-0.0870 ± 0.0507	0.8645 ± 0.0219	0.0067 ± 0.0014	12.94 ± 0.44

As a verification to the value assignment using the Tiger Optics CRDS and “on-demand” dilution standards, the trace methane in the balance air was also analyzed using a Picarro 2401 CRDS and a limited set of gas cylinders ranging from (1 to 740) nmol/mol methane in air (Table 6). As shown in Figure 2, the results from both methods agreed within their associated uncertainties. However, for the final value assignment to the balance air only the Tiger Optics results were used, owing to an insufficient number of gas standards available to produce a reliable calibration curve for the Picarro analyzer.

Table 6. NIST methane in air cylinders used for secondary analysis of balance air 2286493Y. Uncertainties are expressed at approximately 95 % confidence ($k = 2$). NIST primary standard mixtures (PSMs) were prepared gravimetrically in accordance with ISO 6142-1:2015 [4]. Working standards (WSs) were value assigned by comparison to a PSM (12.4 nmol/mol, CAL6517).

Cylinder number	Amount fraction (nmol/mol)	Standard type
CA49602	0.97 ± 1.00	WS
CC66806	1.94 ± 1.00	WS
CA03034	1.94 ± 1.00	WS
FF4206	498.94 ± 1.14	PSM
FF4193	739.99 ± 1.08	PSM

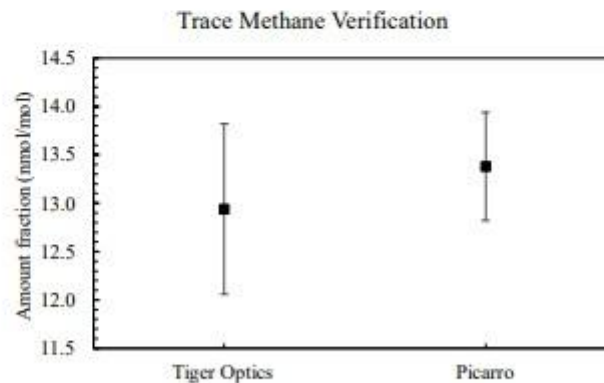
**Figure 2.** Verification of the amount fraction of trace methane in balance air 2286493Y, by comparison of the value assigned using two different instruments and calibration standards. Error bars represent expanded ($k = 2$) uncertainties.

c) Purity table for each of the final mixtures including the value and uncertainty of the methane amount fraction which arises from the sum of trace methane that is a critical impurity in the pure parent/balance gases

Table 7. Gravimetric amount fractions of FF68037.

Component	Amount fraction (mol/mol)	Standard uncertainty (mol/mol)
CH ₄	0.000 001 786 81	0.000 000 000 67
N ₂	0.780 692 195 90	0.000 066 339 08
Ar	0.009 382	0.000 020
O ₂	0.209 483	0.000 037
CO ₂	0.000 440 95	0.000 000 16

Table 8. Gravimetric amount fractions of FF68033.

Component	Amount fraction (mol/mol)	Standard uncertainty (mol/mol)
CH ₄	0.000 002 197 66	0.000 000 000 69
N ₂	0.780 690 803 23	0.000 066 441 25
Ar	0.009 380	0.000 020
O ₂	0.209 487	0.000 037
CO ₂	0.000 440 49	0.000 000 16

d) Uncertainty budget for the final mixtures including gravimetric, stability, verification components and final combined uncertainty

The final amount fraction values and associated uncertainties were assigned to the mixtures in accordance with ISO 6142-1:2015 [4], including contributions from both the gravimetry (y_{prep}) and verification analysis (y_{ver}). The detailed uncertainty budgets for the gravimetric calculations are included in Figures 3 and 4, and the uncertainty contributions from the verification are included in Figure 5. The summarized uncertainty budget for each cylinder is listed in Table 9.

For FF68037, the analyzed and gravimetric values agreed within their corresponding uncertainties, with an overall difference of -0.01 % relative. Therefore, the gravimetric amount fraction was used for the final value assignment:

$$y_{\text{FF68037}} = y_{\text{prep}} \quad (1)$$

and the combined standard uncertainty was calculated as:

$$u_c(y) = \frac{1}{2} \sqrt{u^2(y_{\text{prep}}) + u^2(y_{\text{ver}}) + (y_{\text{prep}} - y_{\text{ver}})^2} \quad (2)$$

For FF68033, the verification revealed a significant bias between the analyzed and gravimetric values, with an overall difference nearly three times the expanded gravimetric uncertainty (0.18 % relative). Since no error could be found within any of the gravimetric calculations, this bias was believed to be attributable to sample preparation, in particular to large variations in environmental conditions during cylinder weighing, causing disruptions in the mass measurements that could not be sufficiently corrected using typical buoyancy correction procedures. As a result, the analyzed amount fraction was used for the final value assignment:

$$y_{\text{FF68033}} = y_{\text{ver}} \quad (3)$$

and the combined standard uncertainty was calculated using Equation 2.

The final expanded uncertainty for both mixtures is expressed as:

$$U(y) = k u_c(y) \quad (4)$$

where the coverage factor k is equal to 2. The true value is therefore asserted to lie in the interval defined by the assigned amount fraction $\pm U$, with a confidence of approximately 95 % [5].

FF68037					
	Value	Standard Uncertainty	Sensitivity Coefficient	Contribution to Uncertainty	%Relative
Major Component MW	28.01371	0.00049	0.0009	0.00000	0.03%
Minor Component MW	16.04250	0.00066	0.0061	0.00000	0.24%
Mass Parent Gas	13.80198	0.00079	0.0099	0.00001	0.46%
Mass Balance Gas	578.75619	0.00086	0.0000	0.00000	0.00%
Minor Component Wt Fraction	0.000042184	0.000000011	17914.4917	0.00020	11.94%
Mass minor component - Parent	0.00058222	0.00000016	1340.2948	0.00022	12.60%
Mass minor component - Bal	0.00000415	0.00000014	1116.9521	0.00016	9.21%
Total mass minor component	0.00058637	0.00000021	2494.2088	0.00053	31.19%
Moles of minor component	0.00003655	0.00000001	41417.6326	0.00056	32.48%
Balance gas wt fraction (purity)	0.754981396	0.00004346	0.1068	0.00000	0.27%
Mass balance gas - parent	10.42328243	0.00156991	0.0000	0.00000	0.00%
Mass balance gas - balance	436.95015474	0.02515826	0.0002	0.00000	0.27%
Total mass balance gas	447.37343716	0.02520720	0.0002	0.00000	0.27%
Moles of balance gas	15.95980326	0.00094230	0.0054	0.00001	0.30%
Moles impurities from parent	0.10436987197	0.00002677525	0.0002	0.00000	0.00%
Moles impurities from balance	4.3817438	0.00082222	0.0047	0.00000	0.23%
Total Moles of gas	20.4559535	0.0012508	0.0072	0.00001	0.53%
Conc minor component (ppm)	1.78681	0.00067			
	Relative uncert	0.037%		0.00171	

Figure 3. Gravimetric value and uncertainty budget for FF68037. The final amount fraction is expressed in $\mu\text{mol/mol}$ with associated combined standard uncertainty.

FF68033					
	Value	Standard Uncertainty	Sensitivity Coefficient	Contribution to Uncertainty	%Relative
Major Component MW	28.01371	0.00049	0.0013	0.00000	0.04%
Minor Component MW	16.04250	0.00066	0.0089	0.00001	0.33%
Mass Parent Gas	14.23941	0.00065	0.0110	0.00001	0.41%
Mass Balance Gas	670.18896	0.00065	0.0000	0.00000	0.00%
Minor Component Wt Fraction	0.000058153	0.000000014	16418.7310	0.00022	12.66%
Mass minor component - Parent	0.00082821	0.00000020	1185.5467	0.00023	13.27%
Mass minor component - Bal	0.00000480	0.00000016	919.5362	0.00015	8.55%
Total mass minor component	0.00083301	0.00000026	2079.7317	0.00053	30.26%
Moles of minor component	0.00005193	0.00000002	34767.3093	0.00056	31.82%
Balance gas wt fraction (purity)	0.754981396	0.00004346	0.1559	0.00001	0.39%
Mass balance gas - parent	10.75348836	0.00133560	0.0000	0.00000	0.00%
Mass balance gas - balance	505.98020042	0.02912725	0.0002	0.00001	0.39%
Total mass balance gas	516.73368877	0.02915786	0.0002	0.00001	0.39%
Moles of balance gas	18.44574277	0.00108985	0.0068	0.00001	0.42%
Moles impurities from parent	0.10768959525	0.00002202428	0.0001	0.00000	0.00%
Moles impurities from balance	5.0739783	0.0009520	0.0060	0.00001	0.32%
Total Moles of gas	23.6274626	0.0014473	0.0091	0.00001	0.75%
Conc minor component (ppm)	2.19766	0.00099			
	Relative uncert	0.032%		0.00176	

Figure 4. Gravimetric value and uncertainty budget for FF68033. The final amount fraction is expressed in $\mu\text{mol/mol}$ with associated combined standard uncertainty.

Data to be fit to a function using ISO 6143 compliant GenLine				Evaluation Data		Execute		Degree = 1		
Value of Standards	Analytical Response	Responses								
Y-Values	Y-uncertainty	X-Values	X-uncertainty	X-Values	X-uncertainty	Value	Std Error			
1637.42	0.56	0.85850	0.00048	1.00000	0.00000	GENLINE - Linear (y=b0+b1*x)				
1756.75	0.72	0.92012	0.00063	0.90896	0.00049					
1836.16	0.75	0.96169	0.00044	0.93601	0.00041	b0	-10.398	3.355		
1892.84	0.79	0.99187	0.00059	0.96647	0.00036	b1	1919.971	3.312		
1929.63	0.64	1.01028	0.00071	1.15214	0.00066	cov(b0,b1)		-11.021		
1933.08	0.78	1.01235	0.00038			rms residual error		0.509		
1969.34	0.75	1.03118	0.00072							
2003.44	0.83	1.04864	0.00066			X	Y	X-Solution	Y-Solution	uTest
2050.12	0.77	1.07246	0.00096			0.85850	1637.42	0.85832	1637.55	PASS
2195.96	0.84	1.14856	0.00086			0.92012	1756.75	0.92033	1756.61	PASS
2926.17	0.98	1.53004	0.00100			0.96169	1836.16	0.96173	1836.10	PASS
						0.99187	1892.84	0.99147	1893.20	PASS
						1.01028	1929.63	1.01042	1929.57	PASS
						1.01235	1933.08	1.01230	1933.19	PASS
						1.03118	1969.34	1.03114	1969.36	PASS
						1.04864	2003.44	1.04881	2003.29	PASS
						1.07246	2050.12	1.07309	2049.91	PASS
						1.14856	2195.96	1.14904	2195.72	PASS
						1.53004	2926.17	1.52960	2926.39	PASS
						Xin	uXin	Yeval	uYeval	
						1.00000	0.00000	1909.57	0.42	
						FF68076	0.90896	0.00049	1734.77	1.08
						FF68037	0.93601	0.00041	1786.71	0.93
						FF4283	0.96647	0.00036	1845.19	0.82
						FF68033	1.15214	0.00066	2201.68	1.42

Figure 5. Analyzed amount fractions and corresponding standard uncertainties for FF68037 and FF68033 (shown in bold), as determined by a first-order GenLine regression [2,3] based on 11 primary standards.

Table 9. Final value assignment and uncertainty budget for FF68037 and FF68033, including contributions from gravimetry (y_{prep}) and verification (y_{ver}). All values are expressed as nmol/mol with associated standard uncertainties. The final expanded uncertainty, $U(y)$, is expressed at approximately 95 % confidence, $k = 2$.

Cylinder	y_{prep} ($u(y_{\text{prep}})$)	y_{ver} ($u(y_{\text{ver}})$)	$y_{\text{prep}} - y_{\text{ver}}$	y ($u_c(y)$)	$U(y)$
FF68037	1786.81 (0.67)	1786.71 (0.93)	0.10	1786.81 (0.57)	1.14
FF68033	2197.66 (0.69)	2201.68 (1.42)	-4.02	2201.68 (2.16)	4.32

Additional non-mandatory information:

e) Brief outline of the dilution series undertaken to produce the final mixtures

The dilution series used to produce the final mixtures comprised a total of five steps starting from pure methane, as illustrated in Figure 6. The cylinders shown in this figure represent a subset of a larger suite of ~40 primary standard mixtures (PSMs), ranging from 10 cmol/mol to 300 nmol/mol. Each step in the dilution series was verified against these additional standards, along with any older PSMs still available. The cylinders prepared in 2010 represent some the original suite of parent mixtures used to prepare the NIST mixtures submitted for participation in CCQM-K82 (2014) [6].

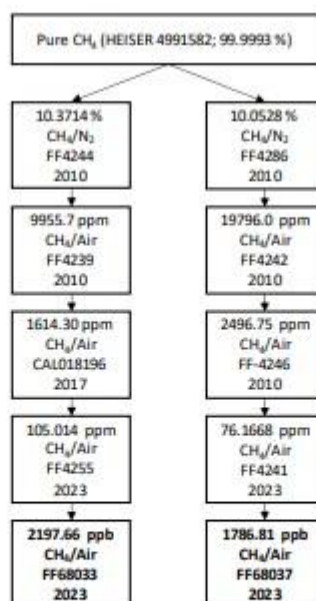

Figure 6. Dilution series used for the preparation of FF68033 and FF68037.

f) Purity table with uncertainties for the nominally pure CH₄ parent gas

Table 10. Purity assay of Heiser methane cylinder 4991582, with associated standard uncertainties.

Component	Amount fraction ($\mu\text{mol/mol}$)	Analytical instrumentation
Ethane	4.2 ± 0.2	GC/FID and HID
Propane	0.4 ± 0.4	GC/FID and HID
Carbon dioxide	0.3 ± 0.3	GC/HID
Argon	<0.1	GC/TCD/HID
Oxygen	0.5 ± 0.2	GC/TCD/HID
Nitrogen	1.7 ± 0.2	GC/FID and HID
Methane	999993.0 ± 0.6	(difference)

g) Brief outline of the verification procedure applied to the final mixtures

The mixtures were analyzed against 11 NIST PSMs ranging from nominal (1600 to 2900) nmol/mol methane in air (Table 11). The PSMs were prepared gravimetrically using a multiple step dilution starting from pure materials. A detailed description of the preparation procedure, including the dilution scheme, purity assays of the starting gases, and verification results, is included in [7].

One of the PSMs, FB03587, was used in CCQM-K82 (2014) [6] and was included in this analysis to ensure consistency within the NIST methane standards and measurement program. The PSM was originally prepared in 2012. The amount fraction assigned during this analysis agreed with the original gravimetric value (and with the KCRV) within the associated uncertainties, indicating stability of the PSMs over time. Those standards which were used to verify FB03587 for CCQM-K82 are also designated in the table.

Table 11. Methane in air primary standards used for verification of FF68037 and FF68033. Listed uncertainties are expressed at approximately 95 % confidence ($k = 2$).

Cylinder number	Amount fraction (nmol/mol)	Air matrix	Year prepared	Link to CCQM-K82
CAL018193	1637.42 ± 1.12	real	2010	
FF4264	1756.75 ± 1.44	real	2013	
FF4288	1836.16 ± 1.50	real	2010	Verification
FF4249	1892.84 ± 1.58	real	2010	Verification
FF4190	1929.63 ± 1.28	synthetic	2011	
FF4295	1933.08 ± 1.56	real	2010	Verification
CAL018216	1969.34 ± 1.50	synthetic	2011	
FF4287	2003.44 ± 1.66	real	2010	Verification
FF4267	2050.12 ± 1.54	real	2010	Verification
FB03587	2195.96 ± 1.68	real	2012	CCQM sample
FF4174	2926.17 ± 1.96	real	2011	

The methane analysis was performed using an Agilent 6890N gas chromatograph with flame ionization detection (GC/FID). The GC was fitted with a 2.74 m × 3.18 mm stainless steel column packed with Carbosieve B 80/100. The column was operated isothermally at 150 °C with UHP helium carrier gas at a flow rate of 35 mL/min. The FID was set to 250 °C, with a fuel gas mixture of 40 mL/min hydrogen and 320 mL/min air.

Gas samples were delivered to the GC using a computer operated gas analysis system (COGAS # 11) and injected onto the head of the column via a 5 mL stainless steel sample loop connected to a 6-port stainless steel gas sampling valve. This automated sampling system randomized the cylinder samples such that detector performance could be monitored for stability through use of an analytical control. Each sample in the measurement sequence was injected four times and the responses were averaged.

The GC/FID was calibrated using the 11 PSMs listed in Table 11. One NIST working standard at nominal 1900 nmol/mol (cylinder GN0018730) was used as the analytical control and was sampled throughout the measurement sequence to account for instrument drift. The PSMs and CCQM samples were each compared to the control a total of nine times over three days. Instrument response ratios (R) were determined as:

$$R = \frac{r_s}{r_c} \quad (5)$$

where r_s is the instrument response of the sample cylinder, and r_c is the drift-corrected response of the control, calculated as:

$$r_c = r_{c1} + \frac{r_{c2} - r_{c1}}{N-1} \cdot (n - 1) \quad (6)$$

In Equation 6, r_{c1} and r_{c2} are the instrument responses of the control taken before and after the sample measurements; N is the total number of measurements in the sampling sequence; and n is the order number of the sample measurement within the sequence.

An ISO 6143 compliant generalized least-squares regression program (GenLine) [2,3] was used to assign a first-order regression to the gravimetric values and response ratios of the PSMs. This regression equation was then used to predict the amount fractions of FF68037 and FF68033 from their response ratios, as shown in Figure 5.

h) Brief outline of any stability testing of the mixtures between the time they are prepared and the time they are shipped to the BIPM.

The mixtures were prepared a few weeks prior to shipment to the BIPM, which did not allow sufficient time for stability testing. NIST will reanalyze the cylinders upon return to ensure stability over the duration of the comparison.

References

- [1] C. Cecelski, K. Harris, C. Goodman, W. Kimes, P. Liu, W. Miller Jr., and J. Carney, Certification of NIST Gas Mixture Standard Reference Materials, Special Publication (NIST SP) 260-222, National Institute of Standards and Technology, Gaithersburg, MD, <https://doi.org/10.6028/NIST.SP.260-222>.
- [2] M.J.T. Milton, P.M. Harris, I.M. Smith, A.S. Brown, and B.A. Goody, Implementation of a generalized least-squares method for determining calibration curves from data with general uncertainty structures, *Metrologia*, 4(4), S291–S298 (2006).
- [3] International Organization for Standardization, ISO 6143:2001 Gas analysis – Comparison methods for determining and checking the composition of calibration gas mixtures, 2nd edition.
- [4] International Organization for Standardization, ISO 6142-1:2015 Gas analysis – Preparation of calibration gas mixtures – Part 1: Gravimetric method for Class I mixtures.
- [5] JCGM 100:2008, Evaluation of measurement data – Guide to the expression of uncertainty in measurement (Gum 1995 with minor corrections), Joint Committee for Guides in Metrology, BIPM, Sèvres, France (2008).
- [6] E. Flores, et al., International comparison CCQM-K82: Methane in air at ambient level (1800-2200) nmol/mol (Final report), *Metrologia*, 52(1A), 08001 (2015).
- [7] G.C. Rhoderick, J. Carney, and F.R. Guenther, NIST gravimetrically prepared atmospheric level methane in dry air standards suite, *Analytical Chemistry*, 84, 3802–3810 (2012).

Cylinders Composition

CH₄ amount fraction

Complete the highlighted cells below with the value of the amount fraction of methane measured in each cylinder, expressed in nmol/mol, the associated expanded uncertainty and its coverage factor k

Standard #	Cylinder ID	x_{CH_4}	$U(x_{\text{CH}_4})$	k
		nmol/mol	nmol/mol	
1	FF68037	1786.81	1.14	2.00
2	FF68033	2201.68	4.32	2.00

Matrix Gas

Complete the cells below with the composition of the matrix gas

Indicate the amount fractions of the three major compounds

Compounds at trace levels may be indicated as well in the columns (other)

Indicate the unit in the cells

Compound	N ₂	O ₂	Ar	CO ₂	CH ₄	Other
Standard #	cmol/mol	cmol/mol	cmol/mol	μmol/mol	nmol/mol	(unit)
1	78.069	20.949	0.938	441	12.94	
2	78.069	20.949	0.938	441	12.94	

Stability

Information to be submitted with mixtures

Key Comparison CCQM-K82.2023 Methane in Air at Ambient level (1800-2200) nmol/mol

Please complete this information sheet for each submitted standard and provide at least the information which is listed as mandatory below. Important: Failure to provide the mandatory information requested will exclude the standard from the set used to calculate the KCRV.

Institute	National Institute of Standards and Technology (NIST)
Address	100 Bureau Drive, Stop 8393 Gaithersburg, MD 20899-8393, USA
Contact	Christina Cecelski; Jennifer Carney
Email	christina.cecelski@nist.gov; jennifer.carney@nist.gov
Telephone	+1(301)975-5185
Transfer Standards (cylinders) Information	

Standard #	ID (Serial Number)	Date of preparation	Pressure	(unit)
1	FF68037	01 Sep 2023	1150 (7.9)	psi (MPa)
2	FF68033	21 Aug 2023	1300 (9.0)	psi (MPa)

Mandatory information

a) Purity table with uncertainties for the nominally pure N₂, O₂, Ar or scrubbed Air and CO₂ parent/balance gases

Table 1. Purity assay of synthetic air 2286493Y, used for preparation of FF68037 and FF68033.

Component	Amount fraction (mol/mol)	Standard uncertainty (mol/mol)
N ₂ (difference)	0.780 687 665 76	0.000 040 811 55
CH ₄	0.000 000 012 94	0.000 000 000 44
Ar	0.009 380	0.000 020
O ₂	0.209 49	0.000 035
CO ₂	0.000 441 00	0.000 000 16

Table 2. Gravimetric amount fractions of parent mixture FF4241, used for preparation of FF68037.

Component	Amount fraction (mol/mol)	Standard uncertainty (mol/mol)
CH ₄	0.000 076 167	0.000 000 019
N ₂	0.780 882 149	0.000 077 975
Ar	0.009 477	0.000 011
O ₂	0.209 126	0.000 050
CO ₂	0.000 438 51	0.000 000 22

Table 3. Gravimetric amount fractions of parent mixture FF4255, used for preparation of FF68033.

Component	Amount fraction (mol/mol)	Standard uncertainty (mol/mol)
CH ₄	0.000 105 014	0.000 000 023
N ₂	0.780 838 458	0.000 064 287
Ar	0.009 392	0.000 019
O ₂	0.209 249	0.000 036
CO ₂	0.000 416 15	0.000 000 15

b) Description of the traceability and measurement method for trace methane (critical impurity) in the pure parent/balance gases

Trace methane in the balance air, 2286493Y, was value assigned by cavity ring-down spectroscopy (CRDS) (Tiger Optics, model LaserTrace3). Due to the limited availability of gas standards containing trace-level methane, value assignment was determined by dilution of a NIST Standard Reference Material (SRM) [1] containing nominal 1 μmol/mol methane in air (Table 4). An Environics Series 4040 gas dilution system was used to dilute the SRM with ultra-high purity (UHP) nitrogen, cylinder TWO7-409050. Sample and dilution flows were varied to produce a series

of dilution setpoints ranging from (1 to 20) nmol/mol, while maintaining a constant total flow of 4900 mL/min.

Table 4. NIST methane in air standard used for value assignment to balance air 2286493Y. Uncertainty is expressed at approximately 95 % confidence ($k = 2$).

SRM number	Sample number	Cylinder number	Certified amount fraction ($\mu\text{mol/mol}$)
1658a	12-2-E	CLM006912	1.19 ± 0.01

A calibration curve was determined from the dilution data using a second-order generalized least-squares regression program (GenLine) compliant with ISO 6143 [2,3]. The average instrument response and uncertainty were plotted on the x-axis, and the calculated amount fraction and uncertainty were plotted on the y-axis, for each dilution setpoint (Figure 1). The resulting regression equation was then used to predict the methane amount fraction in the balance gas, based on its measured instrument response. The regression equation and corresponding amount fraction value are included in Table 5.

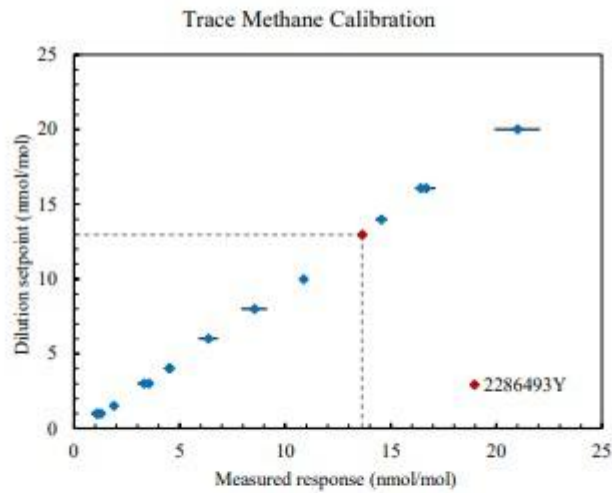

Figure 1. Calibration curve used for trace methane value assignment to balance air cylinder 2286493Y. Blue diamonds represent the amount fraction and corresponding instrument response for each dilution setpoint. The red diamond indicates the measured value and predicted amount fraction for the balance air cylinder. Error bars represent associated expanded ($k = 2$) uncertainties and are displayed for both the x and y axis, but in many cases are too small to be seen on the plot.

Table 5. Regression coefficients (b) and predicted amount fraction (y) for the trace methane in balance air cylinder 2286493Y, with associated standard uncertainties.

$y = b_0 + b_1x + b_2x^2$			y (nmol/mol)
b_0	b_1	b_2	
-0.0870 ± 0.0507	0.8645 ± 0.0219	0.0067 ± 0.0014	12.94 ± 0.44

As a verification to the value assigned using the Tiger Optics CRDS and “on-demand” dilution standards, the trace methane in the balance air was also analyzed using a Picarro 2401 CRDS and a limited set of gas cylinders ranging from (1 to 740) nmol/mol methane in air (Table 6). As shown in Figure 2, the results from both methods agreed within their associated uncertainties. However, for the final value assignment to the balance air only the Tiger Optics results were used, owing to an insufficient number of gas standards available to produce a reliable calibration curve for the Picarro analyzer.

Table 6. NIST methane in air cylinders used for secondary analysis of balance air 2286493Y. Uncertainties are expressed at approximately 95 % confidence ($k = 2$). NIST primary standard mixtures (PSMs) were prepared gravimetrically in accordance with ISO 6142-1:2015 [4]. Working standards (WSs) were value assigned by comparison to a PSM (12.4 nmol/mol, CAL6517).

Cylinder number	Amount fraction (nmol/mol)	Standard type
CA49602	0.97 ± 1.00	WS
CC66806	1.94 ± 1.00	WS
CA03034	1.94 ± 1.00	WS
FF4206	498.94 ± 1.14	PSM
FF4193	739.99 ± 1.08	PSM

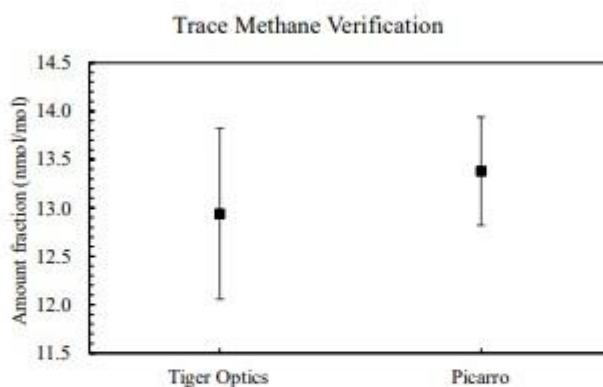
**Figure 2.** Verification of the amount fraction of trace methane in balance air 2286493Y, by comparison of the value assigned using two different instruments and calibration standards. Error bars represent expanded ($k = 2$) uncertainties.

c) Purity table for each of the final mixtures including the value and uncertainty of the methane amount fraction which arises from the sum of trace methane that is a critical impurity in the pure parent/balance gases

Table 7. Gravimetric amount fractions of FF68037.

Component	Amount fraction (mol/mol)	Standard uncertainty (mol/mol)
CH ₄	0.000 001 786 81	0.000 000 000 67
N ₂	0.780 692 195 90	0.000 066 339 08
Ar	0.009 382	0.000 020
O ₂	0.209 483	0.000 037
CO ₂	0.000 440 95	0.000 000 16

Table 8. Gravimetric amount fractions of FF68033.

Component	Amount fraction (mol/mol)	Standard uncertainty (mol/mol)
CH ₄	0.000 002 197 66	0.000 000 000 69
N ₂	0.780 690 803 23	0.000 066 441 25
Ar	0.009 380	0.000 020
O ₂	0.209 487	0.000 037
CO ₂	0.000 440 49	0.000 000 16

d) Uncertainty budget for the final mixtures including gravimetric, stability, verification components and final combined uncertainty

The final amount fraction values and associated uncertainties were assigned to the mixtures in accordance with ISO 6142-1:2015 [4], including contributions from gravimetry (y_{grav}), verification (y_{ver}), and stability (y_{stab}). The detailed uncertainty budgets for the gravimetric calculations are included in Figures 3 and 4, and the uncertainty contributions from the verification and stability analyses are included in Figures 5 and 6, respectively. The summarized uncertainty budget for each cylinder is listed in Table 9.

For FF68037, the analyzed and gravimetric values agreed within their corresponding uncertainties, with an overall difference of -0.01% relative. Therefore, the gravimetric amount fraction was used for the final value assignment:

$$y_{\text{FF68037}} = y_{\text{grav}} \quad (1)$$

and the combined standard uncertainty was calculated as:

$$u_c(y) = \frac{1}{2} \sqrt{u^2(y_{\text{grav}}) + u^2(y_{\text{ver}}) + (y_{\text{grav}} - y_{\text{ver}})^2} \quad (2)$$

For FF68033, the verification revealed a significant bias between the analyzed and gravimetric values, with an overall difference nearly three times the expanded gravimetric uncertainty (0.18 % relative). Since no error could be found within any of the gravimetric calculations, this bias was believed to be attributable to sample preparation, in particular to large variations in environmental conditions during cylinder weighing, causing disruptions in the mass measurements that could not be sufficiently corrected using typical buoyancy correction procedures. As a result, the analyzed amount fraction was used for the final value assignment:

$$y_{\text{FF68033}} = y_{\text{ver}} \quad (3)$$

and the combined standard uncertainty was calculated using Equation 2.

Both mixtures were reanalyzed for stability upon their return to NIST, in July–August 2024. A detailed description of the stability analysis is included in section h. The stability results agreed with the original assigned values within the associated expanded uncertainties, but a notable (positive) offset was observed for FF68037. As a result, no corrections to the amount fractions were made, but the final uncertainties were updated, to include any observed difference between the original value and stability reanalysis, as an approximation of long-term instability (or reproducibility) of the amount fraction over time.

$$u_{\text{final}}(y) = \frac{1}{2} \sqrt{u^2(y_{\text{grav}}) + u^2(y_{\text{ver}}) + (y_{\text{grav}} - y_{\text{ver}})^2 + (\Delta y)^2} \quad (4)$$

The final expanded uncertainty for both mixtures is expressed as:

$$U(y) = k u_{\text{final}}(y) \quad (5)$$

where the coverage factor k is equal to 2. The true value is therefore asserted to lie in the interval defined by the assigned amount fraction $\pm U$, with a confidence of approximately 95 % [5].

FF68037					
	Value	Standard Uncertainty	Sensitivity Coefficient	Contribution to Uncertainty	%Relative
Major Component MW	28.01371	0.00049	0.0009	0.00000	0.03%
Minor Component MW	16.04250	0.00066	0.0061	0.00000	0.24%
Mass Parent Gas	13.80198	0.00079	0.0099	0.00001	0.46%
Mass Balance Gas	578.75618	0.00086	0.0000	0.00000	0.00%
Minor Component Wt Fraction	0.000042184	0.000000011	17914.4917	0.00020	11.94%
Mass minor component - Parent	0.00058222	0.00000016	1340.2948	0.00022	12.60%
Mass minor component - Bal	0.00000415	0.00000014	1116.9521	0.00015	9.21%
Total mass minor component	0.00058637	0.00000021	2494.2088	0.00053	31.19%
Moles of minor component	0.00003655	0.00000001	41417.6326	0.00056	32.48%
Balance gas wt fraction (purity)	0.754981396	0.00004346	0.1068	0.00000	0.27%
Mass balance gas - parent	10.42328243	0.00156991	0.0000	0.00000	0.00%
Mass balance gas - balance	436.95015474	0.02515626	0.0002	0.00000	0.27%
Total mass balance gas	447.37343716	0.02520720	0.0002	0.00000	0.27%
Moles of balance gas	15.96980328	0.00094230	0.0054	0.00001	0.30%
Moles impurities from parent	0.10436987197	0.00002677525	0.0002	0.00000	0.00%
Moles impurities from balance	4.3817438	0.0008222	0.0047	0.00000	0.23%
Total Moles of gas	20.4559535	0.0012508	0.0072	0.00001	0.53%
Conc minor component (ppm)	1.78681	0.00067			
	Relative uncert	0.037%		0.00171	

Figure 3. Gravimetric value and uncertainty budget for FF68037. The final amount fraction is expressed in $\mu\text{mol/mol}$ with associated combined standard uncertainty.

FF68033					
	Value	Standard Uncertainty	Sensitivity Coefficient	Contribution to Uncertainty	%Relative
Major Component MW	28.01371	0.00049	0.0013	0.00000	0.04%
Minor Component MW	16.04250	0.00066	0.0089	0.00001	0.33%
Mass Parent Gas	14.23941	0.00065	0.0110	0.00001	0.41%
Mass Balance Gas	670.18896	0.00065	0.0000	0.00000	0.00%
Minor Component Wt Fraction	0.000058163	0.000000014	16418.7310	0.00022	12.66%
Mass minor component - Parent	0.00082821	0.00000020	1185.5467	0.00023	13.27%
Mass minor component - Bal	0.00000480	0.00000016	919.5362	0.00015	8.55%
Total mass minor component	0.00083301	0.00000026	2079.7317	0.00053	30.26%
Moles of minor component	0.00005193	0.00000002	34767.3093	0.00056	31.82%
Balance gas wt fraction (purity)	0.754981396	0.00004346	0.1559	0.00001	0.39%
Mass balance gas - parent	10.75348836	0.00133560	0.0000	0.00000	0.00%
Mass balance gas - balance	505.98020042	0.02912725	0.0002	0.00001	0.39%
Total mass balance gas	516.73368877	0.02915786	0.0002	0.00001	0.39%
Moles of balance gas	18.44574277	0.00108965	0.0068	0.00001	0.42%
Moles impurities from parent	0.10768059525	0.00002202428	0.0001	0.00000	0.00%
Moles impurities from balance	5.0739783	0.0009520	0.0060	0.00001	0.32%
Total Moles of gas	23.6274626	0.0014473	0.0091	0.00001	0.75%
Conc minor component (ppm)	2.19766	0.00069			
	Relative uncert	0.032%		0.00176	

Figure 4. Gravimetric value and uncertainty budget for FF68033. The final amount fraction is expressed in $\mu\text{mol/mol}$ with associated combined standard uncertainty.

Data to be fit to a function using ISO 6143 compliant GenLine				Evaluation Data		Execute		Degree = 1		
Value of Standards		Analytical Response		Responses						
Y-Values	Y-uncertainty	X-Values	X-uncertainty	X-Values	X-uncertainty					
1637.42	0.56	0.85850	0.00048	1.00000	0.00000	GENLINE - Linear (y=b0+b1*x)				
1756.75	0.72	0.92012	0.00063	0.90896	0.00049	Value Std Error				
1836.16	0.75	0.96169	0.00044	0.93601	0.00041	b0 -10.398 3.355				
1892.84	0.79	0.99187	0.00059	0.96647	0.00036	b1 1919.971 3.312				
1929.63	0.64	1.01028	0.00071	1.15214	0.00066	cov(b0,b1) -11.021				
1933.08	0.78	1.01235	0.00038			rms residual error 0.509				
1969.34	0.75	1.03118	0.00072							
2003.44	0.83	1.04864	0.00066			X	Y	X-Solution	Y-Solution	uTest
2050.12	0.77	1.07246	0.00096			0.85850	1637.42	0.85832	1637.55	PASS
2195.96	0.84	1.14856	0.00086			0.92012	1756.75	0.92033	1756.61	PASS
2926.17	0.98	1.53004	0.00100			0.96169	1836.16	0.96173	1836.10	PASS
						0.99187	1892.84	0.99147	1893.20	PASS
						1.01028	1929.63	1.01042	1929.57	PASS
						1.01235	1933.08	1.01230	1933.19	PASS
						1.03118	1969.34	1.03114	1969.36	PASS
						1.04864	2003.44	1.04881	2003.29	PASS
						1.07246	2050.12	1.07309	2049.91	PASS
						1.14856	2195.96	1.14904	2195.72	PASS
						1.53004	2926.17	1.52960	2926.39	PASS
						XIn	uXIn	Yeval	uYeval	
						1.00000	0.00000	1909.57	0.42	
						FF68076	0.90896	0.00049	1734.77	1.08
						FF68037	0.93601	0.00041	1786.71	0.93
						FF4283	0.96647	0.00036	1845.19	0.82
						FF68033	1.15214	0.00066	2201.68	1.42

Figure 5. Initial verification: amount fractions and standard uncertainties for FF68037 and FF68033 (shown in bold), as determined by first-order GenLine regression [2,3] using 11 PSMs.

Data to be fit to a function using ISO 6143 compliant GenLine				Evaluation Data		Execute		Degree = 1		
Value of Standards		Analytical Response		Responses						
Y-Values	Y-uncertainty	X-Values	X-uncertainty	X-Values	X-uncertainty					
1637.42	0.56	0.85629	0.00102	1.00000	0.00000	GENLINE - Linear (y=b0+b1*x)				
1756.75	0.72	0.91883	0.00052	0.90888	0.00020	Value Std Error				
1836.16	0.75	0.96085	0.00069	0.93607	0.00077	b0 14.405 2.885				
1892.84	0.79	0.99184	0.00100	1.15403	0.00080	b1 1895.513 2.690				
1929.63	0.64	1.01183	0.00082			cov(b0,b1) -7.659				
1933.08	0.78	1.01191	0.00048			rms residual error 0.708				
1969.34	0.75	1.03121	0.00081			X	Y	X-Solution	Y-Solution	uTest
2003.44	0.83	1.04958	0.00083			0.85629	1637.42	0.85624	1637.43	PASS
2050.12	0.77	1.07408	0.00073			0.91883	1756.75	0.91907	1756.51	PASS
2195.96	0.84	1.15032	0.00067			0.96085	1836.16	0.96103	1836.05	PASS
2926.17	0.98	1.53618	0.00059			0.99184	1892.84	0.99112	1893.08	PASS
						1.01183	1929.63	1.01061	1930.02	PASS
						1.01191	1933.08	1.01209	1932.83	PASS
						1.03121	1969.34	1.03132	1969.29	PASS
						1.04958	2003.44	1.04939	2003.54	PASS
						1.07408	2050.12	1.07399	2050.17	PASS
						1.15032	2195.96	1.15073	2195.62	PASS
						1.53618	2926.17	1.53615	2926.20	PASS
						XIn	uXIn	Yeval	uYeval	
						1.00000	0.00000	1909.92	0.49	
						FF68076	0.90888	0.00020	1737.20	0.73
						FF68037	0.93607	0.00077	1788.73	1.57
						FF68033	1.15403	0.00080	2201.89	1.61

Figure 6. Stability reanalysis: amount fractions and standard uncertainties for FF68037 and FF68033 (shown in bold), as determined by first-order GenLine regression [2,3] using 11 PSMs.

Table 9. Final value assignment and uncertainty budget for FF68037 and FF68033, including contributions from gravimetry (y_{grav}), verification (y_{ver}), and stability (Δy). All values are expressed as nmol/mol with associated standard uncertainties. The final expanded uncertainty, $U(y)$, is expressed at approximately 95 % confidence, $k = 2$.

	FF68037	FF68033
y_{grav}	1786.81	2197.66
$u(y_{\text{grav}})$	0.67	0.69
y_{ver}	1786.71	2201.68
$u(y_{\text{ver}})$	0.93	1.42
$y_{\text{grav}} - y_{\text{ver}}$	0.10	-4.02
y	1786.81	2201.68
$u_c(y)$	0.57	2.16
y_{stab}	1788.73	2201.89
$u(y_{\text{stab}})$	1.57	1.61
$\Delta y (y_{\text{stab}} - y)$	1.92	0.21
$u_{\text{final}}(y)$	1.12	2.16
$U(y)$	2.24	4.32

Additional non-mandatory information:

e) Brief outline of the dilution series undertaken to produce the final mixtures

The dilution series used to produce the final mixtures comprised a total of five steps starting from pure methane, as illustrated in Figure 7. The cylinders shown in this figure represent a subset of a larger suite of ~40 PSMs, ranging from 10 cmol/mol to 300 nmol/mol. Each step in the dilution series was verified against these additional standards, along with any older PSMs still available. The cylinders prepared in 2010 represent some of the original suite of parent mixtures used to prepare the NIST mixtures submitted for participation in CCQM-K82 (2014) [6].

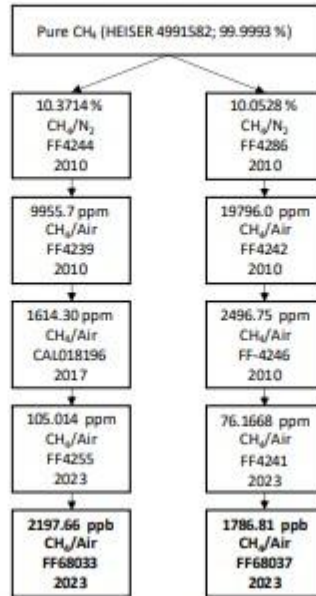

Figure 7. Dilution series used for the preparation of FF68033 and FF68037.

f) Purity table with uncertainties for the nominally pure CH₄ parent gas

Table 10. Purity assay of Heiser methane cylinder 4991582, with associated standard uncertainties.

Component	Amount fraction ($\mu\text{mol/mol}$)	Analytical instrumentation
Ethane	4.2 ± 0.2	GC/FID and HID
Propane	0.4 ± 0.4	GC/FID and HID
Carbon dioxide	0.3 ± 0.3	GC/HID
Argon	< 0.1	GC/TCD/HID
Oxygen	0.5 ± 0.2	GC/TCD/HID
Nitrogen	1.7 ± 0.2	GC/TCD/HID
Methane	999993.0 ± 0.6	(difference)

g) Brief outline of the verification procedure applied to the final mixtures

The mixtures were analyzed against 11 NIST PSMs ranging from nominal (1600 to 2900) nmol/mol methane in air (Table 11). The PSMs were prepared gravimetrically using a multiple step dilution starting from pure materials. A detailed description of the preparation procedure, including the dilution scheme, purity assays of the starting gases, and verification results, is included in [7].

One of the PSMs, FB03587, was used in CCQM-K82 (2014) [6] and was included in this analysis to ensure consistency within the NIST methane standards and measurement program. The PSM was originally prepared in 2012. The amount fraction assigned during this analysis agreed with the original gravimetric value (and with the KCRV) within the associated uncertainties, indicating stability of the PSMs over time. Those standards which were used to verify FB03587 for CCQM-K82 are also designated in the table.

Table 11. Methane in air primary standards used for verification of FF68037 and FF68033. Listed uncertainties are expressed at approximately 95 % confidence ($k = 2$).

Cylinder number	Amount fraction (nmol/mol)	Air matrix	Year prepared	Link to CCQM-K82
CAL018193	1637.42 ± 1.12	real	2011	
FF4264	1756.75 ± 1.44	real	2013	
FF4288	1836.16 ± 1.50	real	2010	Verification
FF4249	1892.84 ± 1.58	real	2010	Verification
FF4190	1929.63 ± 1.28	synthetic	2011	
FF4295	1933.08 ± 1.56	real	2010	Verification
CAL018216	1969.34 ± 1.50	synthetic	2011	
FF4287	2003.44 ± 1.66	real	2010	Verification
FF4267	2050.12 ± 1.54	real	2010	Verification
FB03587	2195.96 ± 1.68	real	2012	CCQM sample
FF4174	2926.17 ± 1.96	real	2011	

The methane analysis was performed using an Agilent 6890N gas chromatograph with flame ionization detection (GC/FID). The GC was fitted with a 2.74 m × 3.18 mm stainless steel column packed with Carbosieve B 80/100. The column was operated isothermally at 150 °C with UHP helium carrier gas at a flow rate of 35 mL/min. The FID was set to 250 °C, with a fuel gas mixture of 40 mL/min hydrogen and 320 mL/min air.

Gas samples were delivered to the GC using a computer operated gas analysis system (COGAS # 11) and injected onto the head of the column via a 5 mL stainless steel sample loop connected to a 6-port stainless steel gas sampling valve. This automated sampling system randomized the cylinder samples such that detector performance could be monitored for stability through use of an analytical control. Each sample in the measurement sequence was injected four times and the responses were averaged.

The GC/FID was calibrated using the 11 PSMs listed in Table 11. One NIST working standard at nominal 1900 nmol/mol (cylinder GN0018730) was used as the analytical control and was sampled throughout the measurement sequence to account for instrument drift. The PSMs and CCQM samples were each compared to the control a total of nine times over three days. Instrument response ratios (R) were determined as:

$$R = \frac{r_s}{r_c} \quad (6)$$

where r_s is the instrument response of the sample cylinder, and r_c is the drift-corrected response of the control, calculated as:

$$r_c = r_{c1} + \frac{r_{c2} - r_{c1}}{N-1} \cdot (n-1) \quad (7)$$

In Equation 7, r_{c1} and r_{c2} are the instrument responses of the control taken before and after the sample measurements; N is the total number of measurements in the sampling sequence; and n is the order number of the sample measurement within the sequence.

An ISO 6143 compliant generalized least-squares regression program (GenLine) [2,3] was used to assign a first-order regression to the gravimetric values and response ratios of the PSMs. This regression equation was then used to predict the amount fractions of FF68037 and FF68033 from their response ratios, as shown in Figure 5.

h) Brief outline of any stability testing of the mixtures between the time they are prepared and the time they are shipped to the BIPM.

The mixtures were prepared a few weeks prior to shipment to the BIPM, which did not allow sufficient time for stability testing. Therefore, the cylinders were reanalyzed upon their return to NIST, approximately 11 months after initial preparation and verification, to evaluate stability over the duration of the comparison.

The comparison mixtures and 11 PSMs were reanalyzed over approximately 3 weeks (for a total of 6 ratios per cylinder), following the same procedure described in section g. The resulting amount fraction values are shown in Figure 6.

During the stability reverification, a shift in the analysis function was observed, as can be seen by comparing the regression parameters in Figures 5 and 6, as well as the black and red dotted lines in Figure 8. This shift yielded a considerable change in the amount fraction value assigned to cylinder FF68037, as shown in Figure 9.

It was not entirely certain whether observed changes in value assignment were related solely to lack of reproducibility of the measurement system, or to instability of the gas mixture. Therefore, although the cylinder amount fraction values were left unchanged, a stability component was incorporated into the final uncertainty (using Equation 4), to conservatively account for any potential deviations over time. The stability uncertainty was applied to both cylinders but made a negligible contribution to the final uncertainty for FF68033.

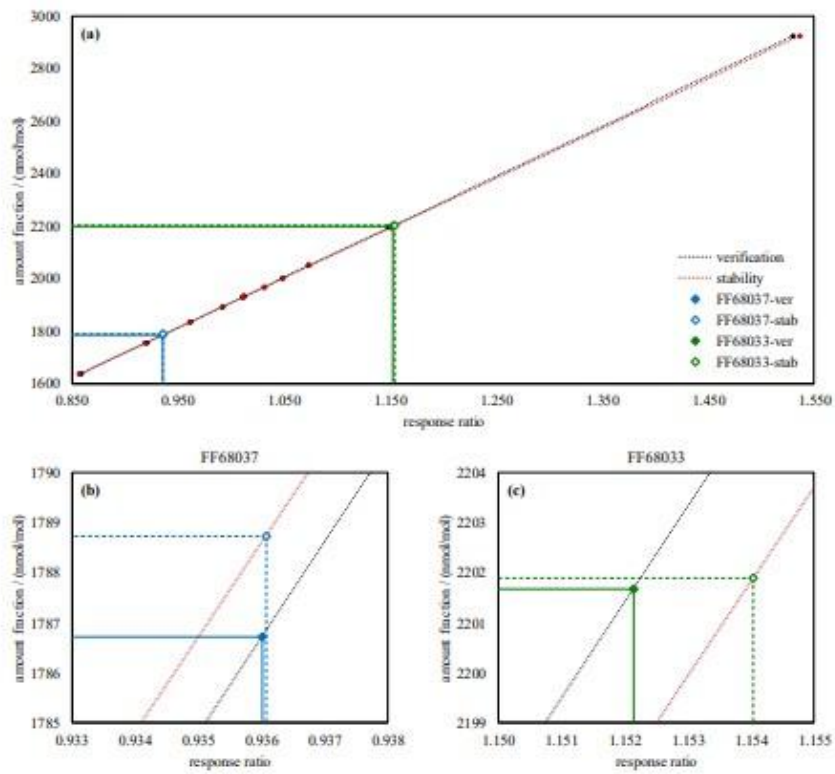

Figure 8. (a) Initial verification (black dotted line with black diamonds) and stability reverification (red dotted line with red diamonds), with zoomed-in subsets shown in (b) and (c). The solid diamonds of blue and green represent the initial verification results for FF68037 and FF68033, respectively, while the open diamonds of the same color represent the results from the stability reanalysis.

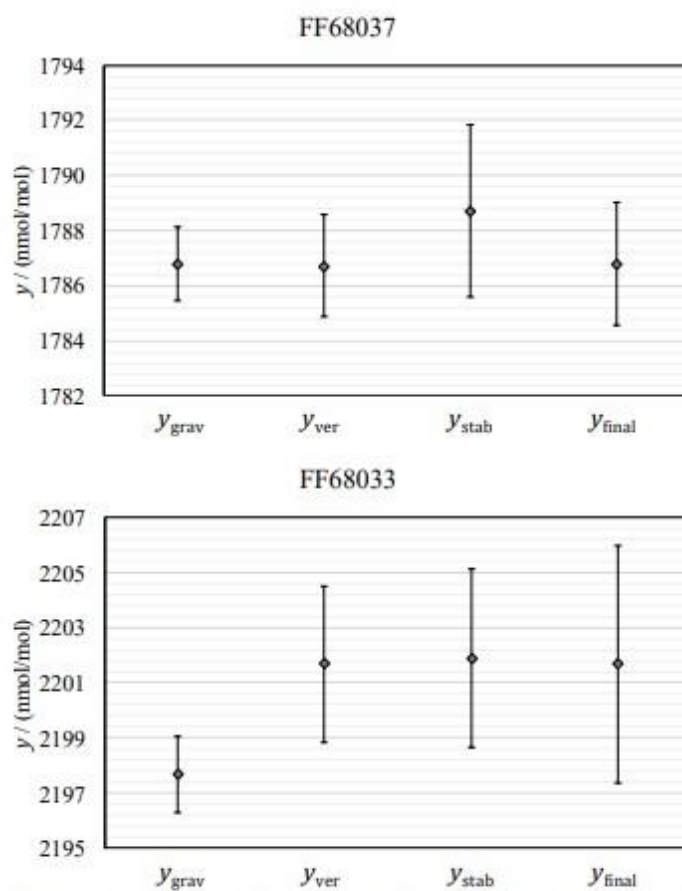

Figure 9. Final amount fraction value (y_{final}) assigned to FF68037 (top) and FF68033 (bottom), as compared to the values determined by gravimetry (y_{grav}), verification (y_{ver}), and stability testing (y_{stab}). Error bars represent associated expanded ($k = 2$) uncertainties.

References

- [1] C. Ceccelski, K. Harris, C. Goodman, W. Kimes, P. Liu, W. Miller Jr., and J. Carney, Certification of NIST Gas Mixture Standard Reference Materials, Special Publication (NIST SP) 260-222, National Institute of Standards and Technology, Gaithersburg, MD, <https://doi.org/10.6028/NIST.SP.260-222>.
- [2] M.J.T. Milton, P.M. Harris, I.M. Smith, A.S. Brown, and B.A. Goody, Implementation of a generalized least-squares method for determining calibration curves from data with general uncertainty structures, *Metrologia*, 4(4), S291–S298 (2006).
- [3] International Organization for Standardization, ISO 6143:2001 Gas analysis – Comparison methods for determining and checking the composition of calibration gas mixtures, 2nd edition.
- [4] International Organization for Standardization, ISO 6142-1:2015 Gas analysis – Preparation of calibration gas mixtures – Part 1: Gravimetric method for Class I mixtures.
- [5] JCGM 100:2008, Evaluation of measurement data – Guide to the expression of uncertainty in measurement (Gum 1995 with minor corrections), Joint Committee for Guides in Metrology, BIPM, Sèvres, France (2008).
- [6] E. Flores, et al., International comparison CCQM-K82: Methane in air at ambient level (1800-2200) nmol/mol (Final report), *Metrologia*, 52(1A), 08001 (2015).
- [7] G.C. Rhoderick, J. Carney, and F.R. Guenther, NIST gravimetrically prepared atmospheric level methane in dry air standards suite, *Analytical Chemistry*, 84, 3802–3810 (2012).

Cylinders Composition

CH₄ amount fraction

Complete the highlighted cells below with the value of the amount fraction of methane measured in each cylinder, expressed in nmol/mol, the associated expanded uncertainty and its coverage factor k

Standard #	Cylinder ID	x_{CH_4}	$U(x_{\text{CH}_4})$	k
		nmol/mol	nmol/mol	
1	FF68037	1786.81	2.24	2.00
2	FF68033	2201.68	4.32	2.00

Matrix Gas

Complete the cells below with the composition of the matrix gas

Indicate the amount fractions of the three major compounds

Compounds at trace levels may be indicated as well in the columns (other)

Indicate the unit in the cells

Compound	N ₂	O ₂	Ar	CO ₂	CH ₄	Other
Standard #	cmol/mol	cmol/mol	cmol/mol	μmol/mol	nmol/mol	(unit)
1	78.069	20.949	0.938	441	12.94	
2	78.069	20.949	0.938	441	12.94	

National Metrology Institute of South Africa (NMISA)

Information to be submitted with mixtures

Key Comparison CCQM-K82.2023 Methane in Air at Ambient level (1800-2200) nmol/mol

Please complete this information sheet for each submitted standard and provide at least the information which is listed as mandatory below. Important: Failure to provide the mandatory information requested will exclude the standard from the set used to calculate the KCRV.

Institute	National Metrology Institute of South Africa
Address	Building 4W CSIR Campus Meiring Naude Road Brummeria 0184
Contact	Mphara Mogale
Email	mmogale@nmisa.org
Telephone	012 947 2816
Transfer Standards (cylinders) Information	

Standard #	ID (Serial Number)		Date of preparation	Pressure	(unit)
1	D73 3629		15 June 2023	104	Bar
2	D67 9445		14 June 2023	118	Bar

Mandatory information

a) Purity table with uncertainties for the nominally pure N₂, O₂, Ar or scrubbed Air and CO₂ parent/balance gases.

Table 1: Purity table with uncertainties for pure Ar gas

Component	Amount fraction (μmol/mol)	Uncertainty (μmol/mol), k=1
Ar	999992,815	0,2372
C ₂ H ₆	0,0385	0,02223
CH ₄	0,02535	0,01464
CO	0,01415	0,00817
CO ₂	0,092	0,05312
H ₂	3,2	0,065
H ₂ O	0,01	0,00577
N ₂	3,8	0,22
O ₂	0,005	0,00289

Table 2: Purity table with uncertainties for pure N₂ gas

Component	Amount fraction (μmol/mol)	Uncertainty (μmol/mol), k=1
Ar	7,2300	0,0470
C ₂ H ₆	0,0385	0,0222
CH ₄	0,0254	0,0146
CO	0,0142	0,0082
CO ₂	0,0920	0,0531
H ₂	2,3900	0,0340
H ₂ O	0,0100	0,0058
N₂	999984,6230	0,2260
O ₂	5,5800	0,2100

Table 3: Purity table with uncertainties for pure CO₂ gas

Component	Amount fraction (μmol/mol)	Uncertainty (μmol/mol), k=1
Ar	0,078	0,045
C ₂ H ₆	0,039	0,022
CH ₄	0,779	0,008
CO	0,014	0,008
CO ₂	999976,998	1,230
H ₂	6,240	0,260
H ₂ O	2,000	1,150
N ₂	10,800	0,290
O ₂	3,013	0,150

Table 4: Purity table with uncertainties for pure O₂ gas

Component	Amount fraction (μmol/mol)	Uncertainty (μmol/mol), k=1
Ar	2,500	1,443
C ₂ H ₆	0,077	0,044
CH ₄	0,051	0,029
CO	0,028	0,016
CO ₂	0,184	0,106
H ₂	2,462	0,073
H ₂ O	1,000	0,577
N ₂	4,046	0,064
O ₂	999989,652	1,562

b) Description of the traceability and measurement method for trace methane (critical impurity) in the pure parent/balance gases.

Measurement method

The amount fraction of trace methane in pure carbon dioxide gas was determined by direct comparison, and by the detection limit method in high pure oxygen, argon and nitrogen, using primary standard gas mixtures prepared by gravimetry in accordance with ISO 6142. Measurements were performed using gas chromatography (GC) coupled with flame ionisation detection (FID) with the following conditions.

Table 5: Measurement parameters for CH₄ impurity in pure balance gases.

Parameter	GC-FID
Oven	35 °C
Detector temp	250 °C
Carrier gas	Helium
Column	Shin Carbon ST
Sample flow	35 ml/min

Traceability

The amount fraction of methane is traceable to the national standard of mass and by comparison, to NMISA primary standard gas mixtures.

- c) Purity table for each of the final mixtures including the value and uncertainty of the methane amount fraction which arises from the sum of trace methane that is a critical impurity in the pure parent/balance gases.

Table 6: Purity table with uncertainties for cylinder D67 94445

Component	Amount fraction ($\mu\text{mol/mol}$)	Uncertainty ($\mu\text{mol/mol}$), $k=1$
N ₂	779933,3428	4,71190396
O ₂	210586,2675	4,61788106
Ar	9001,786607	1,00196841
CO ₂	473,6918603	0,04318383
H ₂	2,41221045	0,02481254
CH ₄	2,21806996	0,01039528
H ₂ O	0,21942615	0,12162678
C ₂ H ₆	0,04663615	0,0157873
CO	0,01720080	0,00580729

Table 7: Purity table with uncertainties for cylinder D73 3629

Component	Amount fraction ($\mu\text{mol/mol}$)	Uncertainty ($\mu\text{mol/mol}$), $k=1$
N ₂	780642,1125	5,19270938
O ₂	210091,0321	4,96090269
Ar	9007,763543	1,88685047
CO ₂	254,5876094	0,04337917
H ₂	2,41171594	0,0264891
CH ₄	1,81262486	0,01113081
H ₂ O	0,21849882	0,12135043
C ₂ H ₆	0,0466118	0,01691109
CO	0,01718791	0,00622105

d) Uncertainty budget for the final mixtures including gravimetric, stability, verification components and final combined uncertainty.

Table 8: Uncertainty budget for final mixtures

Cylinder/Serial Number	Gravimetric Preparation ($\mu\text{mol/mol}$), u_{grav}	Verification uncertainty ($\mu\text{mol/mol}$), u_{ver}	Stability uncertainty ($\mu\text{mol/mol}$), u_{stab}	Combined uncertainty ($\mu\text{mol/mol}$), u_{comb}	Uncertainty ($\mu\text{mol/mol}$), $k=2$
D73 3629	0,01113081	0,0097434	0,0109069	0,0183790	0,037
D67 9445	0,01039528	0,0149737	0,0157640	0,0240993	0,048

Standard #	Cylinder ID	x_{CH_4}	$U(x_{CH_4})$	k
		nmol/mol	nmol/mol	
1	D73 3629	1813	37	2
2	D67 9445	2218	48	2

Matrix Gas

Complete the cells below with the composition of the matrix gas
 Indicate the amount fractions of the three major compounds
 Compounds at trace levels may be indicated as well in the columns (other)
 Indicate the unit in the cells

Compound	N ₂	O ₂	Ar	CO ₂	Other	Other
Standard #	mol/mol	mol/mol	mmol/mol	μmol/mol	(unit)	(unit)
1	0,78064	0,21009	9,007	254,59		
2	0,77993	0,21059	9,001	473,69		

Stability

Information to be submitted with mixtures

Key Comparison CCQM-K82.2023 Methane in Air at Ambient level (1800-2200) nmol/mol

Please complete this information sheet for each submitted standard and provide at least the information which is listed as mandatory below. Important: Failure to provide the mandatory information requested will exclude the standard from the set used to calculate the KCRV.

Institute	National Metrology Institute of South Africa				
Address	Building 4W CSIR Campus Meiring Naude Road Brummeria 0184				
Contact	Mphara Mogale				
Email	mmogale@nmisa.org				
Telephone	012 947 2816				
Transfer Standards (cylinders) Information					
Standard #	ID (Serial Number)		Date of preparation	Pressure	(unit)
1	D73 3629		15 June 2023	104	Bar
2	D67 9445		14 June 2023	118	Bar

Mandatory information

a) Purity table with uncertainties for the nominally pure N₂, O₂, Ar or scrubbed Air and CO₂ parent/balance gases.

Table 1: Purity table with uncertainties for pure Ar gas

Component	Amount fraction (μmol/mol)	Uncertainty (μmol/mol), k=1
Ar	999992,815	0,2372
C ₂ H ₆	0,0385	0,02223
CH ₄	0,02535	0,01464
CO	0,01415	0,00817
CO ₂	0,092	0,05312
H ₂	3,2	0,065
H ₂ O	0,01	0,00577
N ₂	3,8	0,22
O ₂	0,005	0,00289

Table 2: Purity table with uncertainties for pure N₂ gas

Component	Amount fraction (μmol/mol)	Uncertainty (μmol/mol), k=1
Ar	7,2300	0,0470
C ₂ H ₆	0,0385	0,0222
CH ₄	0,0254	0,0146
CO	0,0142	0,0082
CO ₂	0,0920	0,0531
H ₂	2,3900	0,0340
H ₂ O	0,0100	0,0058
N ₂	999984,6230	0,2260
O ₂	5,5800	0,2100

Table 3: Purity table with uncertainties for pure CO₂ gas

Component	Amount fraction (μmol/mol)	Uncertainty (μmol/mol), k=1
Ar	0,078	0,045
C ₂ H ₆	0,039	0,022
CH ₄	0,779	0,008
CO	0,014	0,008
CO ₂	999976,998	1,230
H ₂	6,240	0,260
H ₂ O	2,000	1,150
N ₂	10,800	0,290
O ₂	3,013	0,150

Table 4: Purity table with uncertainties for pure O₂ gas

Component	Amount fraction (μmol/mol)	Uncertainty (μmol/mol), k=1
Ar	2,500	1,443
C ₂ H ₆	0,077	0,044
CH ₄	0,051	0,029
CO	0,028	0,016
CO ₂	0,184	0,106
H ₂	2,462	0,073
H ₂ O	1,000	0,577
N ₂	4,046	0,064
O ₂	999989,652	1,562

b) Description of the traceability and measurement method for trace methane (critical impurity) in the pure parent/balance gases.

Measurement method

The amount fraction of trace methane in pure carbon dioxide gas was determined by direct comparison, and by the detection limit method in high pure oxygen, argon and nitrogen, using primary standard gas mixtures prepared by gravimetry in accordance with ISO 6142. Measurements were performed using gas chromatography (GC) coupled with flame ionisation detection (FID) with the following conditions.

Table 5: Measurement parameters for CH₄ impurity in pure balance gases.

Parameter	GC-FID
Oven	35 °C
Detector temp	250 °C
Carrier gas	Helium
Column	Shin Carbon ST
Sample flow	35 ml/min

Traceability

The amount fraction of methane is traceable to the national standard of mass and by comparison, to NMISA primary standard gas mixtures.

- c) Purity table for each of the final mixtures including the value and uncertainty of the methane amount fraction which arises from the sum of trace methane that is a critical impurity in the pure parent/balance gases.

Table 6: Purity table with uncertainties for cylinder D67 94445

Component	Amount fraction ($\mu\text{mol/mol}$)	Uncertainty ($\mu\text{mol/mol}$), $k=1$
N ₂	779933,3428	4,71190396
O ₂	210586,2675	4,61788106
Ar	9001,786607	1,00196841
CO ₂	473,6918603	0,04318383
H ₂	2,41221045	0,02481254
CH ₄	2,21806996	0,01039528
H ₂ O	0,21942615	0,12162678
C ₂ H ₆	0,04663615	0,0157873
CO	0,01720080	0,00580729

Table 7: Purity table with uncertainties for cylinder D73 3629

Component	Amount fraction ($\mu\text{mol/mol}$)	Uncertainty ($\mu\text{mol/mol}$), $k=1$
N ₂	780642,1125	5,19270938
O ₂	210091,0321	4,96090269
Ar	9007,763543	1,88685047
CO ₂	254,5876094	0,04337917
H ₂	2,41171594	0,0264891
CH ₄	1,81262486	0,01113081
H ₂ O	0,21849882	0,12135043
C ₂ H ₆	0,0466118	0,01691109
CO	0,01718791	0,00622105

d) Uncertainty budget for the final mixtures including gravimetric, stability, verification components and final combined uncertainty.

Table 8: Uncertainty budget for final mixtures (first submission)

Cylinder/Serial Number	Gravimetric Preparation ($\mu\text{mol/mol}$), u_{grav}	Verification uncertainty ($\mu\text{mol/mol}$), u_{ver}	Stability uncertainty ($\mu\text{mol/mol}$), u_{stab}	Combined uncertainty ($\mu\text{mol/mol}$), u_{comb}	Uncertainty ($\mu\text{mol/mol}$), $k=2$
D73 3629	0,01113081	0,0097434	0,0109069	0,0183790	0,037
D67 9445	0,01039528	0,0149737	0,0157640	0,0240993	0,048

Table 9: Uncertainty budget for final mixtures (second submission)

Cylinder/Serial Number	First verification ($\mu\text{mol/mol}$), u_{ver}	Second verification ($\mu\text{mol/mol}$), u_{stab}	Combined uncertainty ($\mu\text{mol/mol}$), u_{comb}	Uncertainty ($\mu\text{mol/mol}$), $k=2$
D73 3629	0,0183790	0,0127988	0,0223964	0,045
D67 9445	0,0240993	0,0156166	0,0287168	0,057

Cylinders Composition

CH₄ amount fraction

Complete the highlighted cells below with the value of the amount fraction of methane measured in each cylinder, expressed in nmol/mol, the associated expanded uncertainty and its coverage factor k

Standard #	Cylinder ID	x_{CH_4}	$U(x_{\text{CH}_4})$	k
		nmol/mol	nmol/mol	
1	D73 3629	1813	45	2
2	D67 9445	2218	57	2

Matrix Gas

Complete the cells below with the composition of the matrix gas

Indicate the amount fractions of the three major compounds

Compounds at trace levels may be indicated as well in the columns (other)

Indicate the unit in the cells

Compound	N ₂	O ₂	Ar	CO ₂	Other	Other
Standard #	mol/mol	mol/mol	mmol/mol	μmol/mol	(unit)	(unit)
1	0,78064	0,21009	9,007	254,59		
2	0,77993	0,21059	9,001	473,69		

National Metrology Institute of Türkiye (UME)

Key Comparison CCQM-K82.2023 Methane in Air at Ambient level (1800-2200) nmol/mol

Participating institute information				
Institute	TÜBİTAK UME			
Address	Baris Mah. Dr. Zeki Acar Cad. No:1 41470 Gebze / Kocaeli TÜRKİYE			
Contact	Tanil Tarhan			
Email	tanil.tarhan@tubitak.gov.tr			
Telephone	+ 90 262 679 5000 / 6401			
Transfer Standards (cylinders) Information				
Standard #	ID (Serial Number)	Date of preparation	Pressure	(unit)
1	PSM034418	04.09.2023	122	bar
2	PSM034390	05.09.2023	121	bar

a) Purity table with uncertainties for the nominally pure N₂, O₂, Ar or scrubbed Air and CO₂ parent/balance gases

Purity tables of the pure gases used in the preparation of the mixtures are given below:

Pure CH₄ (cylinder code: AL6060)

Component	Mole fraction (μmol/mol)	Standard uncertainty (μmol/mol)
H ₂	0.0287	0.0002
Ar	0.1041	0.0050
O ₂	1.6529	0.1036
N ₂	4.9208	0.2183
CH ₄	999993.2004	0.2409
CO	0.0931	0.0029
CO ₂	-	-

Pure N₂ (cylinder code: LG6537)

Component	Mole fraction (μmol/mol)	Standard uncertainty (μmol/mol)
H ₂	0.0313	0.0004
Ar	301.9	0.5
O ₂	3.4902	0.0371
N ₂	999693.9	0.5
CH ₄	0.0036	0.0001
CO	0.3546	0.0048
CO ₂	0.2730	0.0004

Pure O₂ (cylinder code: LG3367)

Component	Mole fraction (μmol/mol)	Standard uncertainty (μmol/mol)
H ₂	-	-
Ar	0.5579	0.0141
O ₂	999998.6522	0.0187
N ₂	0.2804	0.0123
CH ₄	0.004552	0.000005
CO	0.0074	0.0005
CO ₂	0.4976	0.0006

Pure Ar (cylinder code: LG3610)

Component	Mole fraction (μmol/mol)	Standard uncertainty (μmol/mol)
H ₂	0.0341	0.0003
Ar	999999.2078	0.0052
O ₂	-	-
N ₂	0.2017	0.0051
CH ₄	0.1002	0.0004
CO	0.0787	0.0006
CO ₂	0.3776	0.0007

Pure CO₂ (cylinder code: LG0182)

Component	Mole fraction (μmol/mol)	Standard uncertainty (μmol/mol)
H ₂	0.0443	0.0004
Ar	0.1037	0.0035
O ₂	0.4423	0.0779
N ₂	1.3591	0.1295
CH ₄	0.0694	0.0024
CO	0.1373	0.0019
CO ₂	999907.84	0.14

b) Description of the traceability and measurement method for trace methane (critical impurity) in the pure parent/balance gases

Trace methane (CH₄) in pure parent gases were analyzed using Perkin Elmer Clarus 590 gas chromatography (GC) equipped with pulsed discharge helium ionization detector (PDHID). Verification of the mixtures was carried out using own standard, UME034415 (~ 1 μmol/mol each of Ar, CH₄, CO, H₂, N₂, O₂, CO₂ in helium mixture).

Cylinders were equipped with pressure reducers and connected directly to GC using electronic pressure controller before sample inlet in order to keep flows constant. They were flushed three times before the first measurement. Each cylinder was measured 50 replicates which is a sufficient to obtain stable results. The measurement data were collected manually and evaluated using MS Excel.

c) Purity table for each of the final mixtures including the value and uncertainty of the methane amount fraction which arises from the sum of trace methane that is a critical impurity in the pure parent/balance gases

Cylinder	PSM034418		PSM034390	
	Mole fraction (μmol/mol)	Standard uncertainty (μmol/mol)	Mole fraction (μmol/mol)	Standard uncertainty (μmol/mol)
Ar	9381.5469	0.9740	9312.8309	0.9702
CH ₄	1.7945	0.0007	2.2165	0.0009
CO	0.0651	0.0014	0.0652	0.0014
CO ₂	369.7517	0.0861	369.7464	0.0861
H ₂	0.1824	0.0006	0.1827	0.0006
N ₂	780818.6976	6.8565	781798.7964	6.8239
O ₂	209427.9618	6.8586	208516.1619	6.8267

d) Uncertainty budget for the final mixtures including gravimetric, stability, verification components and final combined uncertainty

The basis for the uncertainty budget is formed by the uncertainty evaluation from the gravimetric preparation and analytical measurements. Gravimetric preparation contains uncertainty sources from weighing and those from purity of the parent gases. Gravimetric preparation and uncertainty evaluation have been performed in accordance with ISO 6142-1 [1]. The measurement uncertainty of each mixture was determined according to ISO 6143 [2].

The combined standard uncertainty of each mixture was determined by the following equation:

$$u_c = \sqrt{u_m^2 + u_g^2}$$

where

u_m , standard uncertainty from measurements

u_g , standard uncertainty from gravimetric preparation

The expanded uncertainty was determined by multiplying the combined standard uncertainty by a coverage factor of 2 with a confidence interval of 95%.

e) Brief outline of the dilution series undertaken to produce the final mixtures

Mixtures were prepared according to the scheme shown in Figure 1. Seven different types of the pre-mixtures were prepared. Four of them are methane in nitrogen mixtures with the concentrations of 10 %, 0.5 %, 0.02 %, and 0.005 %, respectively. Two of them are carbon dioxide in nitrogen mixtures with the concentrations of 5 % and 0.5 %. One of them is argon in nitrogen mixture with the concentration of 15 %.

0.005 % methane in nitrogen, 0.5 % carbon dioxide in nitrogen and 15 % argon in nitrogen pre-mixtures were used together with pure nitrogen and pure oxygen for the preparation of final mixtures.

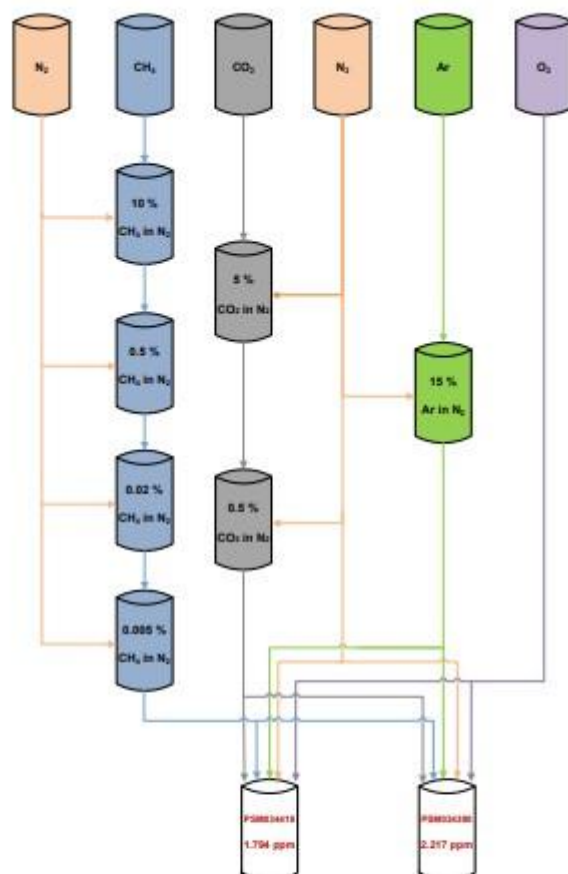

Figure 1. Preparation scheme for the mixtures.

f) Purity table with uncertainties for the nominally pure CH₄ parent gasPure CH₄ (cylinder code: AL6060)

Component	Mole fraction ($\mu\text{mol/mol}$)	Standard uncertainty ($\mu\text{mol/mol}$)
H ₂	0.0287	0.0002
Ar	0.1041	0.0050
O ₂	1.6529	0.1016
N ₂	4.9208	0.2583
D ₂	999993.2004	0.2409
CO	0.0931	0.0029
CO ₂	-	-

g) Brief outline of the verification procedure applied to the final mixtures

Verification of the mixtures was carried out using own standard (UME499834, 99.7 $\mu\text{mol/mol}$ methane in air mixture) by dynamic dilution according to ISO 6145-7 [3].

The standard gas mixture used for the verification of the cylinders was diluted to 3 points (1.5 $\mu\text{mol/mol}$, 2.0 $\mu\text{mol/mol}$ and 2.5 $\mu\text{mol/mol}$) with dynamic dilution system including thermal mass flow controllers (MFC), molbloc-L flow elements controlled with Molboxes and electronic pressure controllers. The capacities of the MFCs used for the dilution were 100 sccm and 5000 sccm. The dilution measurement was maintained until the stable responses were obtained from the CRDS.

During the data evaluation of static cylinders, a total of 95 readings were taken between 14 and 15 minutes to determine average values and uncertainties for each cylinder at each measurement. For the standard used in dynamic dilution, the last 5 minutes of data (475 measurements) were used. The software "CurveFit" was utilized to determine the fitting data for the calibrations. The value for goodness of fit in each measurement was found to be less than 2 in each case for linear function.

References

[1] International Organization for Standardization, ISO 6142-1:2015 "Gas analysis - Preparation of calibration gas mixtures - Part 1: Gravimetric method for Class I mixtures"

[2] International Organization for Standardization, ISO 6143:2001 "Gas analysis - Comparison methods for determining and checking the composition of calibration gas mixtures"

[3] International Organization for Standardization, ISO 6145-7:2018 "Gas analysis - Preparation of calibration gas mixtures using dynamic methods, Part 7: Thermal mass-flow controllers".

Authorship

Participant's List : Dr. Aylin BOZTEPE, Dr. Tanil TARHAN, Dr. Erinc ENGIN, Dilara KURT

Cylinders Composition

CH₄ amount fraction

Complete the highlighted cells below with the value of the amount fraction of methane measured in each cylinder, expressed in nmol/mol, the associated expanded uncertainty and its coverage factor k

Standard #	Cylinder ID	x_{CH_4}	$U(x_{\text{CH}_4})$	k
		nmol/mol	nmol/mol	
1	PSM034418	1794.50	3.14	2
2	PSM034390	2216.51	4.30	2

Matrix Gas

Complete the cells below with the composition of the matrix gas

Indicate the amount fractions of the three major compounds

Compounds at trace levels may be indicated as well in the columns (other)

Indicate the unit in the cells

Compound	N ₂	O ₂	Ar	CO ₂		
Standard #	μmol/mol	μmol/mol	μmol/mol	μmol/mol		
1	780818.7	209428.0	9381.5	369.8		
2	781798.8	208516.2	9312.8	369.7		

Stability

9/25/2024

We performed stability analyses and found that there is no stability issue on our mixtures.

National Oceanic and Atmospheric Administration (NOAA)

Information to be submitted with mixtures

Key Comparison CCQM-K82.2023 Methane in Air at Ambient level (1800-2200) nmol/mol

Please complete this information sheet for each submitted standard and provide at least the information which is listed as mandatory below. Important: Failure to provide the mandatory information requested will exclude the standard from the set used to calculate the KCRV.

Institute	NOAA			
Address	325 Broadway Boulder, CO 80305 USA			
Contact	Brad Hall, Andrew Crotwell			
Email	Bradley.Hall@noaa.gov Andy.Crotwell@noaa.gov			
Telephone	+ 1 720 248 8325			
Transfer Standards (cylinders) Information				
Standard #	ID (Serial Number)	Date of preparation	Pressure	(unit)
1	FB04226	19 April 2023	1950	psi

Mandatory information

a) Purity table with uncertainties for the nominally pure N₂, O₂, Ar or scrubbed Air and CO₂ parent/balance gases

The samples provided for this comparison consist of modified natural air, with CH₄ amount fractions value-assigned by analysis on the WMO-CH₄-X2004A scale. Since samples were not gravimetrically prepared, we cannot provide an uncertainty budget in the customary form. Instead, we provide purity tables for the high-purity CH₄ and purified whole air (dilution gas) that were used to prepare the primary standards upon which the scale is based.

The CH₄ standards that comprise the WMO-CH₄-X2004A scale are descendent from gravimetrically-prepared 1% CH₄ in air mixtures that were prepared in 1991. We have done our best to extract the relevant information here (Dlugokencky et al., 2005, doi:10.1029/2005JD006035), acknowledging that some notes from that time period are incomplete. We have reassessed our uncertainty estimates since the last CCQM-K82 comparison.

There are 22 primary standards that comprise the X2004A scale. Sixteen standards were prepared during 1991-1995. An additional six standards were prepared from an existing 1% parent mixture in 2013.

Purity tables for dilution gas used to prepare primary standards upon which the X2004A scale is based are shown below.

Purity Table: Dilution gas (scrubbed real air), for primary standards made 1991-1995 (N=16)

Component	Mole fraction	Uncertainty (k=1)
O ₂	0.20963	0.00008
N ₂	0.78104	0.00008
Ar	0.00933	0.000003
CO ₂	< 1e-6	0.5e-6
CH ₄	5e-9	2e-9

Purity Table: Dilution gas (scrubbed real air), for primary standards made in 2013 (N=6)

Component	Mole fraction	Uncertainty (k=1)
O ₂	0.20963	0.00008
N ₂	0.78104	0.00008
Ar	0.009332	0.000003
CO ₂	< 1e-6	0.5e-6
CH ₄	3.4e-9	0.7e-9

b) Description of the traceability and measurement method for trace methane (critical impurity) in the pure parent/balance gases;

There are 22 primary standards that comprise the X2004A scale. Sixteen standards were prepared during 1991-1995. An additional six standards were prepared from an existing 1% parent mixture in 2013.

For standards prepared in the 1990s, the GC-FID detection level was not sufficient to quantify trace CH₄ in the dilution gas at levels below ~5 nmol/mol. Instead, it was estimated based on the residuals to a linear fit to GC-FID analysis of the primary standards in 2004 (Dlugokencky et al., 2005) and experience analyzing similar purified whole air in the 2000s (Scott Marrin, Inc) with a limit of detection <= 1 nmol/mol. Dlugokencky et al. (2005) reported an intercept of -5 ± 1 nmol/mol, and adjusted the values of the 1991-1995 primary standards by this amount. This would imply an uncertainty in the dilution gas of 1 nmol/mol ($k=1$). However, residuals from the linear fit of the 1991-1995 primary standards varied by more than twice this value. The full range of residuals, when grouped by preparation method (see Dlugokencky et al., 2005), is ~7 nmol/mol, from which we would derive a standard uncertainty of 2 nmol/mol using a uniform distribution. Therefore, we accept 2 nmol/mol as a better estimate of this uncertainty for all 16 standards prepared in the 1990s.

For standards prepared in 2013, the value and uncertainty of CH₄ in the zero gas was estimated based on measurements by GC-FID, with the response linearly extrapolated from primary standards at nominal 35 and 100 nmol/mol and using integration parameters adjusted to enable detection of small peaks. We detected an average of 3.4 ± 0.7 nmol/mol CH₄ in a series of scrubbed whole air cylinder (Scott Marrin, Inc).

c) Purity table for each of the final mixtures including the value and uncertainty of the methane amount fraction which arises from the sum of trace methane that is a critical impurity in the pure parent/balance gases

The samples provided for this comparison consist of modified natural air, with CH₄ amount fractions value-assigned by analysis on the WMO-CH₄-X2004A scale. Since samples were not gravimetrically prepared, we cannot provide an uncertainty budget in the customary form. Instead, we provide purity tables for the high-purity CH₄ and purified whole air (dilution gas) that were used to prepared the primary standards upon which the scale is based.

d) Uncertainty budget for the final mixtures including gravimetric, stability, verification components and final combined uncertainty

Typical uncertainty budget of a primary standard at 1800 nmol/mol (1991-1995)

Component	Relative Contribution
reagent purity	2%
MW major component	1%
transfer efficiency	2%
MW dilution gas (scrubbed real air)	6%
Mass determination and uncertainty inherited from 1% parent	41%
CH ₄ in dilution gas	47%

Total uncertainty for a typical primary standard (k=1):
 2.6 nmol/mol at 1800 nmol/mol
 3.0 nmol/mol at 2200 nmol/mol

The current analytical system for calibrations is based on a Picarro 2301 (CRDS). Previously, we used a gas chromatograph with flame ionization detection (Dlugokencky et al., 2005). The WMO X2004A CH₄ reference scale is based on 22 gravimetrically-prepared standards, with a nominal range of 300-5000 nmol/mol (see Dlugokencky et al., 2005; https://gml.noaa.gov/ccl/ch4_scale.html). The scale was developed and transferred to 14 secondary standards based on six response curves; 5 from the GC-FID system and one from the CRDS (https://gml.noaa.gov/ccl/ch4_scale.html). To estimate the uncertainty of the X2004A

CH₄ scale, we calculated the uncertainty of each response curve relative to the 22 primary standards, taking into account the repeatability of measurement and the uncertainties in the primary standards, and averaged the uncertainties among the various response curves. Since most of the primary standards are descendent from a single parent mixture, we do not consider the standards as independent in this step. We exclude the uncertainty associated with that parent and add it in quadrature separately. Then we added 0.4 nmol/mol and 0.1 nmol/mol in quadrature to account for the scale transfer uncertainty (primary to secondary) and reproducibility of the tertiary value assignment (secondary to tertiary), respectively. Cylinders FB04227 and FB04226 submitted for this comparison are at the tertiary level in the hierarchy.

The resulting expanded uncertainties for samples FB04227 and FB04226 are 3.4 and 4.1 nmol/mol, respectively.

Additional non-mandatory information:

e) Brief outline of the dilution series undertaken to produce the final mixtures

The mixtures were prepared by filling cylinders with whole air, modified to reach the target mixing ratios by adding ultra-pure air or a high-concentration methane spike. Cylinders were filled using a Rix SA-6A compressor.

f) Purity table with uncertainties for the nominally pure CH₄ parent gas

The CH₄ standards that comprise the WMO-CH₄-X2004A scale are descendent from gravimetrically-prepared 1% CH₄ in air mixtures that were prepared in 1991. We have done our best to extract the relevant information here (Dlugokencky et al., 2005, doi:10.1029/2005JD006035), acknowledging that some notes from that time period are incomplete.

Purity Table: CH₄ reagent

Component	Mole fraction	Uncertainty (k=1)
O ₂	< 100 µmol/mol	
N ₂	< 100 µmol/mol	
H ₂ O ¹	< 10 µmol/mol	
ethane, propane	< 25 µmol/mol	
CH ₄	0.9998+	0.00006

¹analysis by electrolytic method (Meeco)

g) Brief outline of the verification procedure applied to the final mixtures

The samples provided for this comparison consist of modified natural air, with CH₄ amount fractions value-assigned by analysis on the WMO-CH₄-X2004A scale.

h) Brief outline of any stability testing of the mixtures between the time they are prepared and the time they are shipped to the BIPM.

The sample was analyzed three times over a period of 3 weeks during July 2023. No specific stability testing was performed since we have not observed stability problems with methane in air in similar cylinders.

Cylinders Composition

CH₄ amount fraction

Complete the highlighted cells below with the value of the amount fraction of methane measured in each cylinder, expressed in nmol/mol, the associated expanded uncertainty and its coverage factor k

Standard #	Cylinder ID	x_{CH_4}	$U(x_{\text{CH}_4})$	k
		nmol/mol	nmol/mol	
1	FB04227	1813.2	3.4	2
2	FB04226	2200.4	4.1	2

Matrix Gas

Complete the cells below with the composition of the matrix gas

Indicate the amount fractions of the three major compounds

Compounds at trace levels may be indicated as well in the columns (other)

Indicate the unit in the cells

Compound	N ₂	O ₂	Ar	CO ₂	H ₂ O	Other
Standard #	%	%	%	umol/mol	umol/mol	(unit)
1	78.07	20.96	0.93	389	< 2	
2	78.07	20.96	0.93	424	< 2	

Stability

Cylinders Composition

CH₄ amount fraction

Complete the highlighted cells below with the value of the amount fraction of methane measured in each cylinder, expressed in nmol/mol, the associated expanded uncertainty and its coverage factor k

Standard #	Cylinder ID	x_{CH_4}	$U(x_{\text{CH}_4})$	k
		nmol/mol	nmol/mol	
1	FB04227	1813.3	3.4	2
2	FB04226	2200.5	4.1	2

Matrix Gas

Complete the cells below with the composition of the matrix gas
 Indicate the amount fractions of the three major compounds
 Compounds at trace levels may be indicated as well in the columns (other)
 Indicate the unit in the cells

Compound	N ₂	O ₂	Ar	CO ₂	H ₂ O	Other
Standard #	%	%	%	umol/mol	umol/mol	(unit)
1	78.07	20.96	0.93	389	< 2	
2	78.07	20.96	0.93	424	< 2	

National Physical Laboratory (NPL)

Information to be submitted with mixtures

Key Comparison CCQM-K82.2023 Methane in Air at Ambient level (1800-2200) nmol/mol

Please complete this information sheet for each submitted standard and provide at least the information which is listed as mandatory below. Important: Failure to provide the mandatory information requested will exclude the standard from the set used to calculate the KCRV.

Institute	National Physical Laboratory
Address	Hampton Road, Teddington, United Kingdom, TW11 0LW
Contact	Aimee Hillier
Email	aimee.hillier@npl.co.uk
Telephone	+442089437183

Transfer Standards (cylinders) Information

Standard #	ID (Serial Number)	Date of preparation	Pressure	(unit)
1	D133091	18/07/2023	110	bar
2	D132886	18/07/2023	110	bar

Mandatory information**a) Purity table with uncertainties for the nominally pure N₂, O₂, Ar or scrubbed Air and CO₂ parent/balance gases**

Table 1: Purity table for pure nitrogen with expanded uncertainties.

Component	Amount fraction (μmol/mol)	Uncertainty (μmol/mol)
CO	0.00012	0.00015
CO ₂	0.033	0.024
O ₂	0.41	0.19
C ₂ H ₆	0.1	0.029
H ₂ O	0.5	0.14
N ₂	999987.02	0.34
CH ₄	0.00002	0.00021
H ₂	0.1	0.029
Ar	11.84	0.23

Table 2: Purity table for pure oxygen with expanded uncertainties.

Component	Amount fraction (μmol/mol)	Uncertainty (μmol/mol)
CH ₄	0.05698	0.00045
CO	0.0042	0.0011
N ₂	0.5	0.14
O ₂	999998.31	0.25
H ₂	0.05	0.014
Ar	0.5	0.14
H ₂ O	0.5	0.14
CO ₂	0.033	0.024
C ₂ H ₆	0.05	0.014

Table 3: Purity table for pure argon with expanded uncertainties.

Component	Amount fraction (μmol/mol)	Uncertainty (μmol/mol)
Ar	999998.87	0.29
C ₂ H ₆	0.1	0.029
H ₂ O	0.02	0.006
N ₂	1	0.29
O ₂	0.01	0.0029

b) Description of the traceability and measurement method for trace methane (critical impurity) in the pure parent/balance gases:

Purity analysis of the nitrogen and a CH₄ free synthetic air prepared from the same pure argon, oxygen and nitrogen used to prepare the NPL PRMs and matching validation standards for trace CH₄ impurities was carried out using standard addition. A PRM traceable through NPL's hierarchy containing nominally 3 μmol mol⁻¹ methane in synthetic air was diluted with a CH₄ free synthetic air using a custom-built dilutor based on critical flow orifices. Dilution ratios between 1:1100 and 1:150 were achieved through opening combinations of the three 'standard' critical flow orifices. The dilutor is described in detail in

Hill-Pearce et al. (2018).³ A linear regression was generated using the XLgenline software from the amount fraction of methane (x-axis) and the zero-corrected analyser response (y-axis).² The amount fraction of methane in the nitrogen or synthetic air was calculated from where the linear regression intersects the x-axis.

The dilution factor through each of the critical flow orifices was calibrated before use by the dilution of a nominally 2000 $\mu\text{mol mol}^{-1}$ methane in nitrogen PRM and certification of the output through each 'standard' critical flow orifice against a calibration curve produced of methane in nitrogen PRMs in the amount fraction range of 1-8 $\mu\text{mol mol}^{-1}$.

Due to analytical challenges of analysing pure oxygen, the trace methane impurity in the synthetic air was quantified. The trace methane impurity from the nitrogen was subtracted from the synthetic air and the remaining methane impurity scaled by the oxygen amount fraction in the synthetic air to the methane impurity in the pure oxygen. As the Ar/O₂ ratio is the same between the synthetic air used for impurity analysis and the matrix of the NPL PRMs and to simplify the uncertainty calculations, all the methane impurity was assigned to the pure oxygen and the argon was not separately purity analysed.

c) Purity table for each of the final mixtures including the value and uncertainty of the methane amount fraction which arises from the sum of trace methane that is a critical impurity in the pure parent/balance gases

Table 4: Purity table for PRM D133091 showing gravimetric amount fractions with expanded uncertainties.

Component	Amount fraction ($\mu\text{mol/mol}$)	Uncertainty ($\mu\text{mol/mol}$)
N ₂	782729.0	10.6
O ₂	208010.3	11.0
Ar	9258.2	3.7
CH ₄	1.7896	0.0006
H ₂ O	0.5	0.11
C _x H _y	0.09	0.022
H ₂	0.089	0.022
CO ₂	0.033	0.019
CO	0.00097	0.00025

Table 5: Purity table for PRM D132886 showing gravimetric amount fractions with expanded uncertainties

Component	Amount fraction ($\mu\text{mol/mol}$)	Uncertainty ($\mu\text{mol/mol}$)
N ₂	781407.9	10.6
O ₂	209289.0	10.9
Ar	9300.2	3.7
CH ₄	2.1866	0.0006
H ₂ O	0.5	0.11
C _x H _y	0.09	0.022
H ₂	0.089	0.022
CO ₂	0.033	0.019
CO	0.00097	0.00025

d) Uncertainty budget for the final mixtures including gravimetric, stability, verification components and final combined uncertainty

Analytical uncertainty

Following the measurement equation above, the combined uncertainty $u(x_u)$ for a single validation measurement was calculated from:

$$\frac{u(x_u)}{x_u} = \sqrt{\frac{u(x_s)^2}{x_s^2} + \frac{u(\bar{r})^2}{\bar{r}^2}}$$

Where $u(x_s)$ is the standard uncertainty of the validation standard and the standard uncertainty $u(\bar{r})$ is the standard deviation of the four ratio measurements. Sensitivity coefficients are calculated by taking the partial derivative with respect to each measurement input. Table 6 and Table 7 show an example uncertainty budget for one validation of D133091 and D132886 respectively.

Table 6: Example analytical uncertainty budget for a single validation of the NPL PRM D133091 against the in-house validation standard D133099.

	Unit	Value	Standard u/c	Sensitivity coefficient	u/c contribution	u/c type	Distribution
x_s	μmol/mol	1.79E+00	1.22E-03	9.98E-01	1.21E-03	A	normal
\bar{r}	-	9.98E-01	7.01E-05	1.79E+00	1.26E-04	A	normal
x_u	μmol/mol	1.79					
$u(x_u)$	μmol/mol	1.22E-03					
$U(x_u)$	μmol/mol	2.44E-03					

Table 7: Example analytical uncertainty budget for a single validation of the NPL PRM D132886 against the in-house validation standard D133112.

	Unit	Value	Standard u/c	Sensitivity coefficient	u/c contribution	u/c type	Distribution
x_s	μmol/mol	1.79E+00	1.22E-03	9.98E-01	1.21E-03	A	normal
\bar{r}	-	9.98E-01	7.01E-05	1.79E+00	1.26E-04	A	normal
x_u	μmol/mol	1.79					
$u(x_u)$	μmol/mol	1.22E-03					
$U(x_u)$	μmol/mol	2.44E-03					

The analytical uncertainty from the four repeat validations were combined by taking a weighted average, according to the uncertainty in each measurement, to give x_u . Sensitivity coefficients are given to provide equal input from each measurement, giving the analytical uncertainty for the final measurement $u(x_u)$. Table 8 and Table 9 show the combined analytical uncertainty for D133091 and D132886 respectively.

Table 8: Combined analytical uncertainty budget for the four repeat validations of NPL PRM D133091 against the in-house validation standard D133099.

	Unit	Value	Standard u/c	Sensitivity coefficient	u/c contribution	u/c type	Distribution
x_1	μmol/mol	1.7898	1.23E-03	0.25	3.07E-04	A	normal
x_2	μmol/mol	1.7898	1.23E-03	0.25	3.06E-04	A	normal
x_3	μmol/mol	1.7898	1.22E-03	0.25	3.04E-04	A	normal
x_4	μmol/mol	1.7897	1.22E-03	0.25	3.05E-04	A	normal
x_u	μmol/mol	1.7898					

$u(x_a)$	$\mu\text{mol/mol}$	6.11E-04
$U(x_a)$	$\mu\text{mol/mol}$	1.22E-03

Table 9: Combined analytical uncertainty budget for the four repeat validations of NPL PRM D132886 against the in-house validation standard D133112.

	Unit	Value	Standard u/c	Sensitivity coefficient	u/c contribution	u/c type	Distribution
x_1	$\mu\text{mol/mol}$	1.7898	1.23E-03	0.25	3.07E-04	A	normal
x_2	$\mu\text{mol/mol}$	1.7898	1.23E-03	0.25	3.06E-04	A	normal
x_3	$\mu\text{mol/mol}$	1.7898	1.22E-03	0.25	3.04E-04	A	normal
x_4	$\mu\text{mol/mol}$	1.7897	1.22E-03	0.25	3.05E-04	A	normal
x_a	$\mu\text{mol/mol}$	1.7898					
$u(x_a)$	$\mu\text{mol/mol}$	6.11E-04					
$U(x_a)$	$\mu\text{mol/mol}$	1.22E-03					

Combined uncertainty

The combined uncertainty is calculated by summing in quadrature the analytical $u(x_a)$, and gravimetric, $u(x_g)$, uncertainties according to the equation:

$$u(x) = \sqrt{u(x_g)^2 + u(x_a)^2}$$

Table 10: Final uncertainty budget for NPL PRM D133091, combining analytical and gravimetric uncertainty contributions.

	unit	value
$u(x_a)$	$\mu\text{mol/mol}$	6.11E-04
$u(x_g)$	$\mu\text{mol/mol}$	5.92E-04
x	$\mu\text{mol/mol}$	1.79E+00
$u(x)$	$\mu\text{mol/mol}$	8.51E-04
$U(x) (k = 2)$	$\mu\text{mol/mol}$	1.70E-03
$U(x) (k = 2)$	%	0.10

Table 11: Final uncertainty budget for NPL PRM D132886, combining analytical and gravimetric uncertainty contributions.

	unit	value
$u(x_a)$	$\mu\text{mol/mol}$	8.18E-04
$u(x_g)$	$\mu\text{mol/mol}$	6.44E-04
x	$\mu\text{mol/mol}$	2.19E+00
$u(x)$	$\mu\text{mol/mol}$	1.04E-03
$U(x) (k = 2)$	$\mu\text{mol/mol}$	2.08E-03
$U(x) (k = 2)$	%	0.10

Additional non-mandatory information:

e) Brief outline of the dilution series undertaken to produce the final mixtures

Two NPL primary reference materials (D133091 and D132886) were prepared by gravimetry in accordance with ISO 6142-1 in 10 L aluminium cylinders treated with Spectraseal™ (BOC) internal passivation process.³ The PRMs were prepared from dilution from a nominally 2000 $\mu\text{mol mol}^{-1}$

methane in nitrogen parent cylinder (D132897) via an indirect transfer vessel addition. A transfer vessel addition was also used to prepare the methane parent cylinder, by the addition of pure methane (N6.0, CK gases). The NPL PRMs were prepared in a synthetic air matrix by the direct addition of argon (BIP, Air products), nitrogen (Alphagaz 2, Air Liquide) and oxygen (N6.0, BOC) targeted to atmospheric blending ratios. The argon was added from a nominally 30 cmol mol^{-1} argon in nitrogen parent mixture (D132918). Two validation reference materials (D133099 and D133112) were prepared in the same way from the nominally $2000 \text{ } \mu\text{mol mol}^{-1}$ methane in nitrogen parent cylinder (D133106). The dilution hierarchy is detailed in Figure 1, and the composition of the two PRMs are detailed in Table 4 and Table 5.

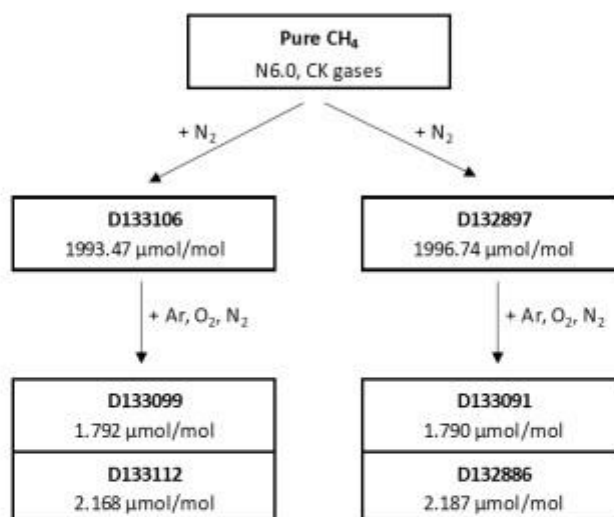

Figure 1: Dilution hierarchy for the preparation of four NPL PRMs from pure methane; two NPL PRMs sent to the coordinating laboratory (D133091 and D132886) and two NPL PRMs used as validation standards at NPL (D133099 and D133112).

f) Purity table with uncertainties for the nominally pure CH₄ parent gas

Component	Amount fraction ($\mu\text{mol/mol}$)	Uncertainty ($\mu\text{mol/mol}$)
CH ₄	999999.01	0.15
N ₂	0.38	0.06
O ₂	0.2	0.03
C _x H _y	0.02	0.003
H ₂ O	0.39	0.06

g) Brief outline of the verification procedure applied to the final mixtures

Two in house validation standards were prepared at matching amount fractions to the NPL PRM comparison mixtures. The amount fraction of the NPL PRMs were validated against their matching standards and other historic NPL in house standards at the same nominal amount fraction as the NPL PRMs using cavity ring-down spectroscopy (Picarro, G2301). A regulator was used to reduce the pressure of the PRMs to 2 bar (g) before introduction to the analyser, with an overflow of 0.5 L min^{-1}

vented to the atmosphere to ensure a stable (atmospheric) inlet pressure and to prevent contamination with laboratory air. Each PRM was introduced to the analyser for five minutes, and the sequence repeated four times. The stable analyser response to each five-minute sample was averaged. A synthetic air reference material prepared from the same argon, oxygen, and nitrogen as the NPL PRMs was sampled before and after the sequence of PRMs to subtract the analyser response to the matrix gas.

For each measurement sequence, a ratio of the matrix subtracted analyser response to the NPL PRM and in-house validation standard was calculated according to the equation:

$$r = \frac{(y_u - y_z)}{(y_c - y_z)}$$

Where y_u , y_c , and y_z are the analyser response to the NPL PRM, in-house validation standard and the CH₄ free synthetic air respectively. The analytically certified amount fraction of the NPL PRM (x_u) was determined by multiplying the average ratio (\bar{r}) across the four sequence repeats against the gravimetric amount fraction of the in-house validation standard (x_c) according to the equation:

$$x_u = x_c \bar{r}$$

The analytical uncertainty within a measurement is determined through the repeatability in the NPL PRM validated amount fraction across the four sequence repeats. The validation procedure was repeated on four separate dates between 21/07/2023 and 25/09/2023.

h) Brief outline of any stability testing of the mixtures between the time they are prepared and the time they are shipped to the BIPM.

The two NPL PRMs were validated against their matching standards and historical NPL PRMs with the same amount fraction range four times between 21/07/2023 and 25/09/2023. All certified amount fractions of the NPL PRMs agreed with the gravimetric amount fractions within the expanded uncertainty ($k=2$).

References:

1. Hill-Pearce, R. E.; Resner, K. V.; Worton, D. R.; Brewer, P. J., Synthetic Zero Air Reference Material for High Accuracy Greenhouse Gas Measurements. *Analytical chemistry* **2018**, *91* (3), 1974-1979.
2. NPL, XLGENLINE V1.1.
3. ISO, 6142-1: Gas analysis-Preparation of calibration gas mixtures-Part 1: Gravimetric method for Class I mixtures. *Geneva, Switzerland* **2015**.

Cylinders Composition

CH₄ amount fraction

Complete the highlighted cells below with the value of the amount fraction of methane measured in each cylinder, expressed in nmol/mol, the associated expanded uncertainty and its coverage factor k

Standard #	Cylinder ID	x_{CH_4}	$U(x_{\text{CH}_4})$	k
		nmol/mol	nmol/mol	
1	D133091	1789.6	1.7	2
2	D132886	2186.6	2.1	2

Matrix Gas

Complete the cells below with the composition of the matrix gas

Indicate the amount fractions of the three major compounds

Compounds at trace levels may be indicated as well in the columns (other)

Indicate the unit in the cell: (unit)

Compound	N ₂	O ₂	Ar	CO ₂	Other	Other
Standard #	μmol/mol	μmol/mol	μmol/mol	μmol/mol	(unit)	(unit)
1	782729.0	208010.3	9258.2	0.033		
2	781407.9	209289.0	9300.2	0.033		

Stability

6/28/2024

We have completed the re-measurement of our K82 mixtures, we have seen no drift or stability issues in the measurements. Therefore we are happy with the values submitted when the mixtures were sent to BIPM.

National Physical Laboratory (NPLI)

Information to be submitted with mixtures

Key Comparison CCQM-K82.2023 Methane in Air at Ambient level (1800-2200) nmol/mol

Please complete this information sheet for each submitted standard and provide at least the information which is listed as mandatory below. Important: Failure to provide the mandatory information requested will exclude the standard from the set used to calculate the KCRV.

Institute	CSIR-National Physical Laboratory; NPLI
Address	CSIR-National Physical Laboratory, Dr. K.S. Krishnan Marg, New Delhi – 110012, INDIA
Contact	Dr Daya Soni
Email	dsoni@nplindia.org
Telephone	+91 11 47091628
Transfer Standards (cylinders) Information	

Standard #	ID (Serial Number)	Date of preparation	Pressure	(unit)
1.	D001986	22.08.2023	115	Bar
2.	D001989	14.08.2023	115	Bar

Mandatory information

a) Purity table with uncertainties for the nominally pure N₂, O₂, Ar or scrubbed Air and CO₂ parent/balance gases

Pure balance gas	CH ₄ (nmol/mol)	u (at k=1) (nmol/mol)	H ₂ O (μmol/mol)	u (at k=1) (μmol/mol)	CO (μmol/mol)	u(at k=1) (μmol/mol)
Argon	0.03	0.01	0.81	0.06	0.27	0.04
Oxygen	7.37	0.05	0.95	0.03	ND	-
Nitrogen	0.42	0.23	1.96*	0.41	0.80	0.03

*moisture in balance nitrogen includes average data of nitrogen cylinders used for premixtures preparation. Moisture in nitrogen cylinders used in final preparation could not be determined due to technical problem with moisture CRDS analyser.

b) Description of the traceability and measurement method for trace methane (critical impurity) in the pure parent/balance gases;

CW-CRDS analyzer of 'Tiger Optics' with model "Laser Trace" is used for moisture quantification which has an operational range of 0–500 ppm and a sensitivity of 100 ppt. Model "MTO-1000-CH4" is used for determination of methane in N₂, O₂ and Ar balance gases and the operational range for methane is 0-5000 ppm with a sensitivity of 1 ppb. CO measurement in balance gases was done using CRDS Model HALO 3 F7602 with serial no. 4467-91-0. The operational range of CRDS for CO is 0-20000 ppb. For H₂O, CH₄, and CO, the lowest detection limits are 200 ppt, 2 ppb, and 100 ppb, respectively. CO₂ is determined by GC-FID (Agilent 6890 N) with methanizer using Hayesep-D SS column (80/ 100 mesh, 1/8 OD, 10 ft). Limit of detection for CO₂ measured via GC-FID is 0.73 ppm calculated using signal to noise ratio for NPLI prepared Primary Reference Gas Mixture (PRGM)

Analysis of impurities was done in controlled environmental conditions at (23±2) °C temperature and (45±15) % RH. The temperature stability of gas mixtures was reassured by storing them in the laboratory overnight before analysis. A pressure regulator and stainless-steel tubing is used for the sample gas introduction into the analyzer to avoid any chances of permeation of air from the ambient. For the determination of impurities, N₂ cylinder was connected to each CRDS analyzer in which all kinds of trace impurities are to be quantified. The Balance gas cylinder was connected to a sample line of CRDS analyzer maintaining the flow of 0.5–1 lpm in the sample line. The sample was then introduced into the ring-down cavity via a

pressure regulator at around 2 bar line pressure for continuous 1 hours to get a steady concentration of trace impurity obtained. The same sample cylinder was connected to the CRDS sample line for further three days.

Measurement of all the reported impurities are done three times in the respective balance gas and Type A uncertainty is estimated from standard deviation and uncertainty is reported at $k=1$. CO in O₂ balance could not be determined as O₂ matrix was not allowed in HALO 3 model used for measurement of CO.

Balance gas	Impurities	Measurement Method	Traceability
Argon	CH ₄	CRDS	NPLI CH ₄ PRGM
	CO	CRDS	NPLI CO PRGM
	H ₂ O	CRDS	-
Oxygen	CH ₄	CRDS	NPLI CH ₄ PRGM
	H ₂ O	CRDS	-
Nitrogen	CH ₄	CRDS	NPLI CH ₄ PRGM
	CO	CRDS	NPLI CO PRGM
	H ₂ O	CRDS	-
	CO ₂	GC-FID (Agilent 6890 N) with methanizer using Hayesep-D SS column (80/ 100 mesh, 1/8"OD, 10 ft).	NPLI CO ₂ PRGM

*CRDS for moisture was calibrated by NIST moisture standards by the vender at the time of purchase.

c) Purity table for each of the final mixtures including the value and uncertainty of the methane amount fraction which arises from the sum of trace methane that is a critical impurity in the pure parent/balance gases

Cylinder No D001986

Component	Mole fraction	Expanded Uncertainty (k=2)
CH ₄	1787.45 nmol/mol	3.69 nmol/mol
Ar	0.009343 mol/mol	0.000030 mol/mol
O ₂	0.20832 mol/mol	0.00060 mol/mol
N ₂	0.78233 mol/mol	0.00153 mol/mol

Cylinder No D001989

Component	Mole fraction; $\mu\text{mol/mol}$	Expanded Uncertainty (k=2)
CH ₄	2199.66 nmol/mol	4.54 nmol/mol
Ar	0.009607 mol/mol	0.000023 mol/mol
O ₂	0.20912 mol/mol	0.00049 mol/mol
N ₂	0.78127 mol/mol	0.00184 mol/mol

d) Uncertainty budget for the final mixtures including gravimetric, stability, verification components and final combined uncertainty

The final uncertainty budget was estimated by combining two uncertainty components (i.e., preparation of PRGM and its verification analysis).

I. Gravimetric Uncertainty estimation of all the prepared gas mixtures (PRGMs) has been calculated according to ISO 6142: Preparation of Calibration gas mixtures – Gravimetric method taking into consideration of following factors:

1. Raymor Balance
2. Mass Pieces
3. Buoyancy corrections for weights
4. Handling of cylinder
5. Residual gases in the cylinder
6. Expansion of the cylinder due to filling of gas at High pressure

II. Uncertainties in the verification analysis includes following contributing factors

1. Repeatability

2. Reproducibility &

3. Instrument response

Uncertainty due to verification analysis is 0.25 % relative at (k=1)

Uncertainty budget in the table includes preparative uncertainty (both gravimetric and uncertainty due to impurities analysis) as given by the equation.

$$x_{i,\text{prep}} = x_{i,\text{grav}} + \Delta x_{i,\text{purity}}$$

$$u^2(x_{i,\text{prep}}) = u^2(x_{i,\text{grav}}) + u^2(\Delta x_{i,\text{purity}})$$

Uncertainty Budget for the Cylinder D001986 (Only preparative uncertainty budget)

		Mass Values	Evaluation Type A & B	Distribution	standard uncertainty	Sensitivity coefficient	uncertainty contribution
Weighing 1st Premixture	CH ₄	55.5635 g			0.0061 g	0.0049724	3.0332E-05
	N ₂	1353.1710 g	A, B	Normal	0.0078 g	0.0322743	0.00025174
Weighing 2nd Premixture	CH ₄	43.2626 g	A, B	Normal	0.0048 g	0.000698	3.3482E-06
	N ₂	1305.3894	A, B	Normal	0.0059 g	0.000022	1.3219E-07
Weighing 3rd Premixture	CH ₄	63.6600 g	A, B	Normal	0.0091 g	-0.0007	-6.6701E-06
	N ₂	1300.2870 g	A, B	Normal	0.0102 g	0.00000004	4.3251E-10
Weighing Final mixture Premixture :		23.8019 g	A, B	Normal	0.0188 g	-0.0005	-6.4853E-06
	Ar	18.2844 g	A, B	Normal	0.0194 g	-0.0004	-8.6284E-06
	O ₂	328.5575 g	A, B	Normal	0.0197 g	-0.0003	-5.9983E-06
	N ₂	1049.8155 g	A, B	Normal	0.0219 g	0.0001	2.1941E-06
	uc	nmol/mol					0.454
	uc (impurity measurement)		0.1% rel				1.787
	Combined standard uncertainty (nmol/mol)						1.844
	Expanded uncertainty (k=2)						3.688

Uncertainty Budget for the Cylinder D001989

	Mass Values	Evaluation Type A & B	Distribution	standard uncertainty	Sensitivity coefficient	uncertainty contribution	
Weighing 1st Premixur	CH4	55.5635 g		0.0061 g	0.00497	3.03E-05	
	N2	1353.171 g	A, B	Normal	0.0078 g	0.03227	2.52E-04
Weighing 2nd Premixur	CH4	43.2626 g	A, B	Normal	0.0048 g	0.00070	3.35E-06
	N2	1305.3894 g	A, B	Normal	0.0059 g	0.00002	1.32E-07
Weighing 3rd Premixur	CH4	61.495 g	A, B	Normal	0.0119 g	-0.00074	-6.67E-06
	N2	1294.604 g	A, B	Normal	0.0144 g	0.00000	4.33E-10
Weighing Final mixture	Premixture	30.1188 g	A, B	Normal	0.0159 g	-0.00045	-8.49E-06
	Ar	18.7923 g	A, B	Normal	0.0165 g	-0.00044	-8.63E-06
	O2	327.6485 g	A, B	Normal	0.0178 g	-0.00030	-6.00E-06
	N2	1041.5398 g	A, B	Normal	0.0189 g	0.00010	2.19E-06
	uc (nmol/mol)					0.559	
	uc (impurity measurement)	0.1% ref				2.200	
	Combined standard uncertainty (nmol/mol)					2.270	
	Expanded uncertainty (k=2)					4.539	

Additional non-mandatory information:

e) Brief outline of the dilution series undertaken to produce the final mixtures

All pre mixtures of CH₄/N₂ were prepared gravimetrically following ISO 6142-1 standard. An equal arm double pan gas balance (Raymer HCE-25G) with 25 kg maximum capacity and 1 mg sensitivity, calibrated at NPLI, is used for preparation of all PRGMs. The balance is kept in a vibration free room and temperature and RH maintained at (23±2) °C and (45±15) % throughout the period of preparation of PRGMs. A complete preparation scheme including gas mixtures of CCQM.K82.2023 is given in Fig 1.

The gravimetric preparation procedure involves following steps

Preparation of gas mixtures of CH₄/ N₂ :

Aluminum cylinders (Make; Luxfer, UK) with 10 L water capacity are used for gas mixture preparation. Vacuum system (Make; Zinke, Germany) was used for the evacuation of cylinder up to 10⁻³ mbar with simultaneously heating at 60-70 °C to remove trace gases present in the cylinder. Transfer of component gas (pure methane) and balance gas (nitrogen) was done using a gas filling system (Make: Zinke, Germany). Al cylinders 10 litre were evacuated and purged with nitrogen gas and again evacuated with heating of the cylinders at 60-70°C. This process is repeated thrice before any preparation of gas mixture was carried out. The theoretical calculations were carried out for the desired concentrations as per ISO 6142.

Gas mixtures of CH₄ in nitrogen gas from pure gas were prepared in three steps. First series of first step was prepared in the concentrations around 6.69 and 5.11 cmol/mol. These gas mixtures were diluted in the concentration ranges from (2000 to 2200 μmol/mol) which were further diluted in the range of 100-120 μmol/mol. A fresh 100 μmol/mol CH₄/N₂ gas mixture is prepared and compared with already prepared gas mixtures of the same ranges. These cylinders were validated in accordance to ISO 6143: Gas analysis - Comparison method for determining and checking the composition of calibration gas mixtures.

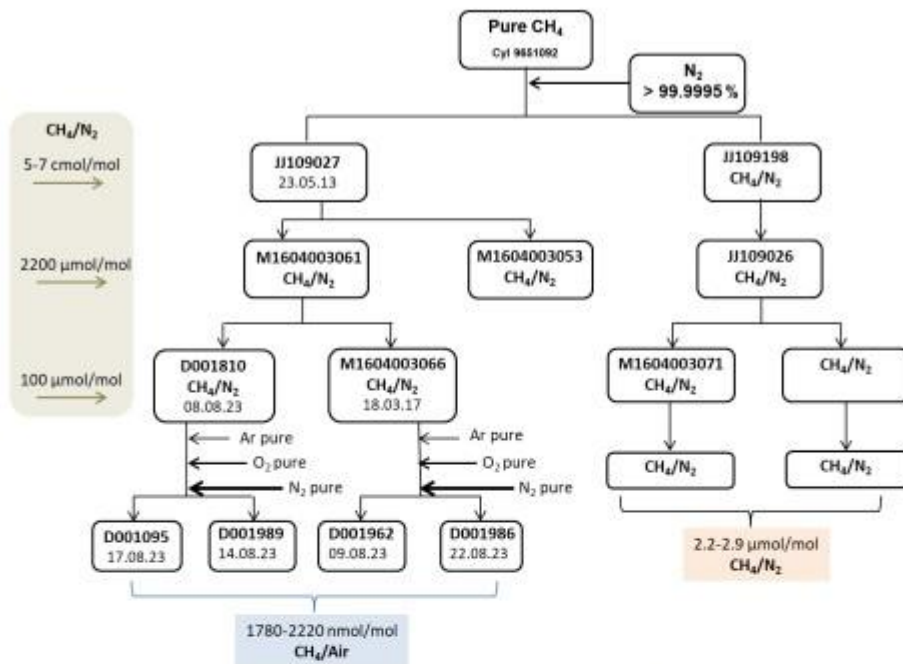

Fig 1. Dilution series of CH₄ in synthetic air

Preparation of CH₄ in Synthetic air :

In Final step, four mixtures were prepared from the two series of CH₄ premixtures prepared in nitrogen gas in the concentration around 100 and 103 μmol/mol. The theoretical calculations for all the four components were carried out simulating the desired concentration range as given in CCQM K-82.2023 protocol. The required amount of pre mixture of CH₄ in Nitrogen is transferred in the pre prepared evacuated cylinder. These mixtures were now added with desired amount of pure Argon gas, pure oxygen gas and finally top up has been done by nitrogen gas to simulate the synthetic air concentration. Two cylinders were prepared in the ranges of 1780-1790 nmol/mol methane in synthetic air each from 100 and 103 μmol/mol CH₄/N₂ premixture and two were prepared in the range of 2190-2220 nmol/mol each from 100 and 103 μmol/mol CH₄/N₂ premixture. CO₂ balance gas is not added to the mixture.

f) Purity table with uncertainties for the nominally pure CH₄ parent gas

Pure methane (Cyl no. 9651092) of 99.998 % procured from Spectra gases, USA was used for the preparation of premixtures used for preparation of final mixtures for this key comparison. The gas was checked for the CO, CO₂ using GC FID but the other impurities are not detected.

g) Brief outline of the verification procedure applied to the final mixtures

Verification of CH₄ in Synthetic Air Mixtures

The prepared synthetic air gas mixture cylinders were verified for CH₄ composition with using above prepared mixtures of CH₄ in Synthetic air PRGM as per ISO 6143.

The standard and sample gases were first injected using stream selection valve and MFC into 10-port gas sampling valves of the Agilent Gas Chromatograph with flame ionization detector (FID) Model 6890N/ US 10723001. The Analytical Condition are given in table:

Method	DEF_GC.S
Oven Temp	40 °C
Column 1	Porapak Q , 80/100; 1/8" OD, 10 ft
Carrier gas	HELIUM
Column Flow	60 mL/min
Detector	FID
Detector Temperature	270 °C
Aux 1 Temp (GSV)	100 °C
Injector	100 °C
Valve 2 GSV	2 mL loop
Valve 7	Multi position SSV
H ₂ Flow	35 mL/min
Air Flow	400 mL/min
MFC	40 mL/min

The average response was calculated by using the repeatable data values rejecting first two values each time for each measurement series. The analysis of the cylinders was carried out minimum three times. The collected data is analyzed and the uncertainty budget was evaluated.

h) Brief outline of any stability testing of the mixtures between the time they are prepared and the time they are shipped to the BIPM.

Although the stability testing of the CH₄ in synthetic air gas mixtures prepared for this key comparison is not done but the stability testing of premixtures of CH₄ in N₂ used for the preparation of final mixtures and other ambient range CH₄ in N₂ has been tested in the laboratory for last five years for long term stability and found to be stable for their gravimetric prepared values. So no uncertainty contribution from stability testing is included in the uncertainty budget of the prepared gas mixtures.

Cylinder Pressure shipped to BIPM

Date of shipping 29th Aug 2023

Standard	Cylinder No	Sample code	Pressure
Standard 1	D001986	L1	115 bar (1668 psi)
Standard 2	D 001989	H2	115 bar (1668 psi)

Other Information: The work related to preparation, verification and data analysis was done by Dr Daya Soni, Dr Khem Singh and Dr Shankar G Aggarwal.

Cylinders Composition

CH₄ amount fraction

Complete the highlighted cells below with the value of the amount fraction of methane measured in each cylinder, expressed in nmol/mol, the associated expanded uncertainty and its coverage factor k

Standard #	Cylinder ID	x_{CH_4}	$U(x_{CH_4})$	k
		nmol/mol	nmol/mol	
1	D001986	1787.45	3.69	2
2	D001989	2199.66	4.54	2

Matrix Gas

Complete the cells below with the composition of the matrix gas

Indicate the amount fractions of the three major compounds

Compounds at trace levels may be indicated as well in the columns (other)

Indicate the unit in the cells

Compound	N ₂	O ₂	Ar	CO ₂	Other	Other
Standard #	mol/mol	mol/mol	mol/mol	μmol/mol	(unit)	(unit)
1	0.7823	0.2083	0.00934	0.00	ND	ND
2	0.7813	0.2091	0.00961	0.00	ND	ND

Stability

Information to be submitted with mixtures

Key Comparison CCQM-K82.2023 Methane in Air at Ambient level (1800-2200) nmol/mol

Please complete this information sheet for each submitted standard and provide at least the information which is listed as mandatory below. Important: Failure to provide the mandatory information requested will exclude the standard from the set used to calculate the KCRV.

Institute	CSIR-National Physical Laboratory; NPLI
Address	CSIR-National Physical Laboratory, Dr. K.S. Krishnan Marg, New Delhi – 110012, INDIA
Contact	Dr Daya Soni
Email	dsoni@nplindia.org
Telephone	+91 11 47091628
Transfer Standards (cylinders) Information	

Standard #	ID (Serial Number)	Date of preparation	Pressure	(unit)
1.	D001986	22.08.2023	115	Bar
2.	D001989	14.08.2023	115	Bar

Mandatory information

a) Purity table with uncertainties for the nominally pure N₂, O₂, Ar or scrubbed Air and CO₂ parent/balance gases

Pure balance gas	CH ₄ (nmol/mol)	u (at k=1) (nmol/mol)	H ₂ O (μmol/mol)	u (at k=1) (μmol/mol)	CO (μmol/mol)	u(at k=1) (μmol/mol)
Argon	0.03	0.01	0.81	0.06	0.27	0.04
Oxygen	7.37	0.05	0.95	0.03	ND	-
Nitrogen	0.42	0.23	1.96*	0.41	0.80	0.03

*moisture in balance nitrogen includes average data of nitrogen cylinders used for premixtures preparation. Moisture in nitrogen cylinders used in final preparation could not be determined due to technical problem with moisture CRDS analyser.

b) Description of the traceability and measurement method for trace methane (critical impurity) in the pure parent/balance gases;

CW-CRDS analyzer of 'Tiger Optics' with model "Laser Trace" is used for moisture quantification which has an operational range of 0–500 ppm and a sensitivity of 100 ppt. Model "MTO-1000-CH₄" is used for determination of methane in N₂, O₂ and Ar balance gases and the operational range for methane is 0-5000 ppm with a sensitivity of 1 ppb. CO measurement in balance gases was done using CRDS Model HALO 3 F7602 with serial no. 4467-91-0. The operational range of CRDS for CO is 0-20000 ppb. For H₂O, CH₄, and CO, the lowest detection limits are 200 ppt, 2 ppb, and 100 ppb, respectively. CO₂ is determined by GC-FID (Agilent 6890 N) with methanizer using Hayesep-D SS column (80/ 100 mesh, 1/8 OD, 10 ft). Limit of detection for CO₂ measured via GC-FID is 0.73 ppm calculated using signal to noise ratio for NPLI prepared Primary Reference Gas Mixture (PRGM)

Analysis of impurities was done in controlled environmental conditions at (23±2) °C temperature and (45±15) % RH. The temperature stability of gas mixtures was reassured by storing them in the laboratory overnight before analysis. A pressure regulator and stainless-steel tubing is used for the sample gas introduction into the analyzer to avoid any chances of permeation of air from the ambient. For the determination of impurities, N₂ cylinder was connected to each CRDS analyzer in which all kinds of trace impurities are to be quantified. The Balance gas cylinder was connected to a sample line of CRDS analyzer maintaining the flow of 0.5–1 lpm in the sample line. The sample was then introduced into the ring-down cavity via a

pressure regulator at around 2 bar line pressure for continuous 1 hours to get a steady concentration of trace impurity obtained. The same sample cylinder was connected to the CRDS sample line for further three days.

Measurement of all the reported impurities are done three times in the respective balance gas and Type A uncertainty is estimated from standard deviation and uncertainty is reported at $k=1$. CO in O₂ balance could not be determined as O₂ matrix was not allowed in HALO 3 model used for measurement of CO.

Balance gas	Impurities	Measurement Method	Traceability
Argon	CH ₄	CRDS	NPLI CH ₄ PRGM
	CO	CRDS	NPLI CO PRGM
	H ₂ O	CRDS	-
Oxygen	CH ₄	CRDS	NPLI CH ₄ PRGM
	H ₂ O	CRDS	-
Nitrogen	CH ₄	CRDS	NPLI CH ₄ PRGM
	CO	CRDS	NPLI CO PRGM
	H ₂ O	CRDS	-
	CO ₂	GC-FID (Agilent 6890 N) with methanizer using Hayesep-D SS column (80/ 100 mesh, 1/8"OD, 10 ft).	NPLI CO ₂ PRGM

*CRDS for moisture was calibrated by NIST moisture standards by the vender at the time of purchase.

c) Purity table for each of the final mixtures including the value and uncertainty of the methane amount fraction which arises from the sum of trace methane that is a critical impurity in the pure parent/balance gases

Cylinder No D001986

Component	Mole fraction	Expanded Uncertainty (k=2)
CH ₄	1787.45 nmol/mol	3.69 nmol/mol
Ar	0.009343 mol/mol	0.000030 mol/mol
O ₂	0.20832 mol/mol	0.00060 mol/mol
N ₂	0.78233 mol/mol	0.00153 mol/mol

Cylinder No D001989

Component	Mole fraction	Expanded Uncertainty (k=2)
CH ₄	2199.66 nmol/mol	4.54 nmol/mol
Ar	0.009607 mol/mol	0.000023 mol/mol
O ₂	0.20912 mol/mol	0.00049 mol/mol
N ₂	0.78127 mol/mol	0.00184 mol/mol

d) Uncertainty budget for the final mixtures including gravimetric, stability, verification components and final combined uncertainty

The final uncertainty budget was estimated by combining two uncertainty components (i.e., preparation of PRGM and its verification analysis).

I. Gravimetric Uncertainty estimation of all the prepared gas mixtures (PRGMs) has been calculated according to ISO 6142: Preparation of Calibration gas mixtures – Gravimetric method taking into consideration of following factors:

1. Raymor Balance
2. Mass Pieces
3. Buoyancy corrections for weights
4. Handling of cylinder
5. Residual gases in the cylinder
6. Expansion of the cylinder due to filling of gas at High pressure

II. Uncertainties in the verification analysis includes following contributing factors

1. Repeatability

2. Reproducibility &

3. Instrument response

Uncertainty due to verification analysis is 0.25 % relative at (k=1)

Uncertainty budget in the table includes preparative uncertainty (both gravimetric and uncertainty due to impurities analysis) as given by the equation.

$$x_{i,\text{prep}} = x_{i,\text{grav}} + \Delta x_{i,\text{purity}}$$

$$u^2(x_{i,\text{prep}}) = u^2(x_{i,\text{grav}}) + u^2(\Delta x_{i,\text{purity}})$$

Uncertainty Budget for the Cylinder D001986 (Only preparative uncertainty budget)

		Mass Values	Evaluation Type A & B	Distribution	standatd uncertainty	Sensitivity coefficient	uncertainty contribution
Weighing 1st Premixture	CH ₄	55.5635 g			0.0061 g	0.0049724	3.0332E-05
	N ₂	1353.1710 g	A, B	Normal	0.0078 g	0.0322743	0.00025174
Weighing 2nd Premixture	CH ₄	43.2526 g	A, B	Normal	0.0048 g	0.000698	3.3482E-06
	N ₂	1305.3894	A, B	Normal	0.0059 g	0.000022	1.3219E-07
Weighing 3rd Premixture	CH ₄	63.6600 g	A, B	Normal	0.0091 g	-0.0007	-6.6701E-08
	N ₂	1300.2870 g	A, B	Normal	0.0102 g	0.00000004	4.3251E-10
Weighing Final mixture Premixture :		23.8019 g	A, B	Normal	0.0188 g	-0.0005	-8.4853E-08
	Ar	18.2844 g	A, B	Normal	0.0194 g	-0.0004	-8.6284E-08
	O ₂	328.5575 g	A, B	Normal	0.0197 g	-0.0003	-5.9983E-08
	N ₂	1049.8155 g	A, B	Normal	0.0219 g	0.0001	2.1941E-08
	uc	nmol/mol					0.454
	uc (impurity measurement)		0.1% rel				1.787
	Combined standard uncertainty (nmol/mol)						1.844
	Expanded uncertainty (k=2)						3.688

Uncertainty Budget for the Cylinder D001989

		Mass Values	Evaluation Type A & B	Distribution	standard uncertainty	Sensitivity coefficient	uncertainty contribution
Weighing 1st Premixur	CH4	55.5635 g			0.0061 g	0.00497	3.03E-05
	N2	1353.171 g	A, B	Normal	0.0078 g	0.03227	2.52E-04
Weighing 2nd Premixur	CH4	43.2626 g	A, B	Normal	0.0048 g	0.00070	3.35E-06
	N2	1305.3894 g	A, B	Normal	0.0059 g	0.00002	1.32E-07
Weighing 3rd Premixur	CH4	61.495 g	A, B	Normal	0.0119 g	-0.00074	-6.67E-06
	N2	1294.604 g	A, B	Normal	0.0144 g	0.00000	4.33E-10
Weighing Final mixture	Premixture :	30.1188 g	A, B	Normal	0.0159 g	-0.00045	-8.49E-06
	Ar	18.7923 g	A, B	Normal	0.0165 g	-0.00044	-8.63E-06
	O2	327.6485 g	A, B	Normal	0.0178 g	-0.00030	-8.00E-06
	N2	1041.5398 g	A, B	Normal	0.0189 g	0.00010	2.19E-06
	uc	(nmol/mol)					0.559
	uc (impurity measurement)		0.1% rel				2.200
	Combined standard uncertainty (nmol/mol)						2.270
	Expanded uncertainty (k=2)						4.539

Additional non-mandatory information:

e) Brief outline of the dilution series undertaken to produce the final mixtures

All pre mixtures of CH₄/N₂ were prepared gravimetrically following ISO 6142-1 standard. An equal arm double pan gas balance (Raymer HCE-25G) with 25 kg maximum capacity and 1 mg sensitivity, calibrated at NPLI, is used for preparation of all PRGMs. The balance is kept in a vibration free room and temperature and RH maintained at (23±2) °C and (45±15) % throughout the period of preparation of PRGMs. A complete preparation scheme including gas mixtures of CCQM.K82.2023 is given in Fig 1.

The gravimetric preparation procedure involves following steps

Preparation of gas mixtures of CH₄/ N₂ :

Aluminum cylinders (Make; Luxfer, UK) with 10 L water capacity are used for gas mixture preparation. Vacuum system (Make; Zinke, Germany) was used for the evacuation of cylinder up to 10⁻³ mbar with simultaneously heating at 60-70 °C to remove trace gases present in the cylinder. Transfer of component gas (pure methane) and balance gas (nitrogen) was done using a gas filling system (Make: Zinke, Germany). All cylinders 10 litre were evacuated and purged with nitrogen gas and again evacuated with heating of the cylinders at 60-70°C. This process is repeated thrice before any preparation of gas mixture was carried out. The theoretical calculations were carried out for the desired concentrations as per ISO 6142.

Gas mixtures of CH₄ in nitrogen gas from pure gas were prepared in three steps. First series of first step was prepared in the concentrations around 6.69 and 5.11 cmol/mol. These gas mixtures were diluted in the concentration ranges from (2000 to 2200 μmol/mol) which were further diluted in the range of 100-120 μmol/mol. A fresh 100 μmol/mol CH₄/N₂ gas mixture is prepared and compared with already prepared gas mixtures of the same ranges. These cylinders were validated in accordance to ISO 6143: Gas analysis - Comparison method for determining and checking the composition of calibration gas mixtures.

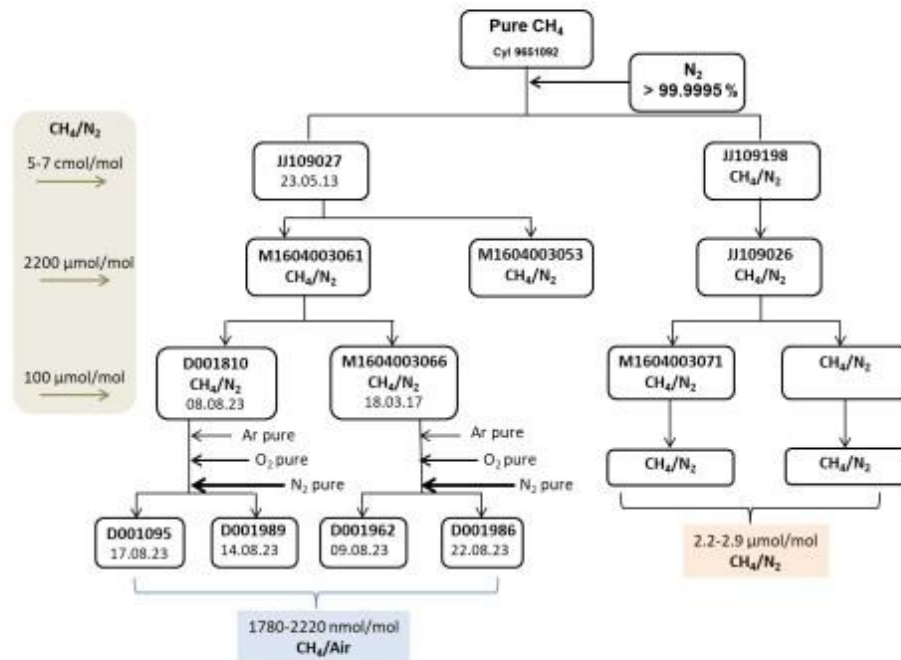
Fig 1. Dilution series of CH₄ in synthetic air

Preparation of CH₄ in Synthetic air :

In Final step, four mixtures were prepared from the two series of CH₄ premixtures prepared in nitrogen gas in the concentration around 100 and 103 μmol/mol. The theoretical calculations for all the four components were carried out simulating the desired concentration range as given in CCQM K-82.2023 protocol. The required amount of pre mixture of CH₄ in Nitrogen is transferred in the pre prepared evacuated cylinder. These mixtures were now added with desired amount of pure Argon gas, pure oxygen gas and finally top up has been done by nitrogen gas to simulate the synthetic air concentration. Two cylinders were prepared in the ranges of 1780-1790 nmol/mol methane is synthetic air each from 100 and 103 μmol/mol CH₄/N₂ premixture and two were prepared in the range of 2190-2220 nmol/mol each from 100 and 103 μmol/mol CH₄/N₂ premixture. CO₂ balance gas is not added to the mixture.

f) Purity table with uncertainties for the nominally pure CH₄ parent gas

Pure methane (Cyl no. 9651092) of 99.998 % procured from Spectra gases, USA was used for the preparation of premixtures used for preparation of final mixtures for this key comparison. The gas was checked for the CO, CO₂ using GC FID but the other impurities are not detected.

g) Brief outline of the verification procedure applied to the final mixtures

Verification of CH₄ in Synthetic Air Mixtures

The prepared synthetic air gas mixture cylinders were verified for CH₄ composition with using above prepared mixtures of CH₄ in Synthetic air PRGM as per ISO 6143.

The standard and sample gases were first injected using stream selection valve and MFC into 10-port gas sampling valves of the Agilent Gas Chromatograph with flame ionization detector (FID) Model 6890N/ US 10723001. The Analytical Condition are given in table:

Method	DEF_GC.S
Oven Temp	40 °C
Column 1	Porapak Q , 80/100; 1/8" OD, 10 ft
Carrier gas	HELIUM
Column Flow	60 mL/min
Detector	FID
Detector Temperature	270 °C
Aux 1 Temp (GSV)	100 °C
Injector	100 °C
Valve 2 GSV	2 mL loop
Valve 7	Multi position SSV
H ₂ Flow	35 mL/min
Air Flow	400 mL/min
MFC	40 mL/min

The average response was calculated by using the repeatable data values rejecting first two values each time for each measurement series. The analysis of the cylinders was carried out minimum three times. The collected data is analyzed and the uncertainty budget was evaluated.

h) Brief outline of any stability testing of the mixtures between the time they are prepared and the time they are shipped to the BIPM.

Although the stability testing of the CH₄ in synthetic air gas mixtures prepared for this key comparison is not done but the stability testing of premixtures of CH₄ in N₂ used for the preparation of final mixtures and other ambient range CH₄ in N₂ has been tested in the laboratory for last five years for long term stability and found to be stable for their gravimetric prepared values. So no uncertainty contribution from stability testing is included in the uncertainty budget of the prepared gas mixtures.

Cylinder Pressure shipped to BIPM

Date of shipping 29th Aug 2023

Standard	Cylinder No	Sample code	Pressure
Standard 1	D001986	L1	115 bar (1668 psi)
Standard 2	D 001989	H2	115 bar (1668 psi)

Result of Stability testing after receiving samples from BIPM

Uncertainty Estimation

Analysis of CH₄ in synthetic air gas mixture is done after 12 months of preparation using gravimetrically prepared primary reference gas mixtures as calibration standards. Uncertainty due to verification analysis is added to the preparative uncertainty to get the final uncertainty of assigned value of CH₄ in synthetic air gas mixture as per given equation:

$$u^2(x_i) = u^2(x_{i,prep}) + u^2(x_{i,ver}) \quad (1)$$

The analytical uncertainty components used for estimation of verification uncertainty are:

1. Repeatability and reproducibility
2. Instrument (GC) response in form of peak area
3. Primary reference gas mixture standard

In the case of calculation of amount fraction of a gas using GC (i.e., concentration against peak area), the sensitivity coefficient is taken as 1. Hence, the combined verification uncertainty is calculated using equation (2):

$$\left[\frac{u_{\text{ver(sample)}}}{x_{\text{sample}}} \right] = \sqrt{\left[\frac{u(x_y)}{x_{\text{sample}}} \right]^2 + \left[\frac{u(GC_{\text{response}})}{GC_{\text{response}}} \right]^2 + \left[\frac{u(x_{\text{PRGM}})}{x_{\text{PRGM}}} \right]^2} \quad (2)$$

After incorporation verification uncertainty, the expanded uncertainty for both the mixtures of methane in synthetic air is given in table below:

Cylinder No D001986

Component	Mole fraction; x_1 nmol/mol	u_{prep} nmol/mol	u_{ver} nmol/mol	u_c nmol/mol	U, Expanded Uncertainty ($k=2$) nmol/mol
CH ₄	1787.45	1.85	4.74	5.08	10.17

Cylinder No D001989

Component	Mole fraction nmol/mol	u_{prep} nmol/mol	u_{ver} nmol/mol	u_c nmol/mol	U, Expanded Uncertainty ($k=2$) nmol/mol
CH ₄	2199.66	2.27	3.32	4.02	8.04

Other Information: The work related to preparation, verification and data analysis was done by Dr Daya Soni, Dr Khem Singh and Dr Shankar G Aggarwal.

Cylinders Composition

CH₄ amount fraction

Complete the highlighted cells below with the value of the amount fraction of methane measured in each cylinder, expressed in nmol/mol, the associated expanded uncertainty and its coverage factor k

Standard #	Cylinder ID	x_{CH_4}	$U(x_{\text{CH}_4})$	k
		nmol/mol	nmol/mol	
1	D001986	1787.45	10.17	2
2	D001989	2199.66	8.04	2

Matrix Gas

Complete the cells below with the composition of the matrix gas

Indicate the amount fractions of the three major compounds

Compounds at trace levels may be indicated as well in the columns (other)

Indicate the unit in the cells

Compound	N ₂	O ₂	Ar	CO ₂	Other	Other
Standard #	mol/mol	mol/mol	mol/mol	μmol/mol	(unit)	(unit)
1	0.7823	0.2083	0.00934	0.00	ND	ND
2	0.7813	0.2091	0.00961	0.00	ND	ND

Bibliography

1. H. Nara, H. Tanimoto, Y. Tohjima, H. Mukai, Y. Nojiri, K. Katsumata and C. W. Rella, *Atmos. Meas. Tech.*, 2012, **5**, 2689-2701.
2. E. Flores, J. Viallon, T. Choteau, P. Moussay, R. I. Wielgosz, N. Kang, B. M. Kim, E. Zalewska, A. A. M. H. v. d. Veen, L. Konopelko, H. Wu, H. Qiao, G. Rhoderick, F. R. Guenther, T. Watanabe, T. Shimosaka, K. Kato, B. Hall and P. Brewer, *Metrologia (Tech.Suppl.)*, 2014 **Volume 52**.
3. E. Flores, F. Idrees, P. Moussay, T. Choteau and R. Wielgosz, Vienne, 2014.