

# TDCR: Triple-to-Double Coincidence Ratio

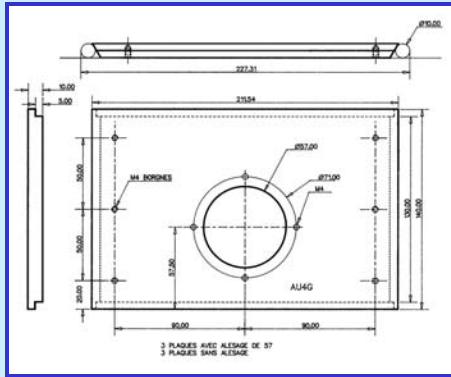

Side view of the measuring chamber

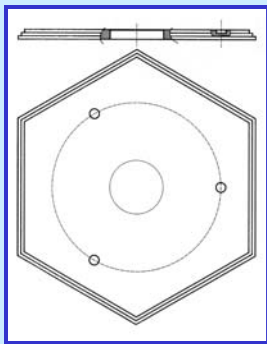

Cover of the measuring chamber

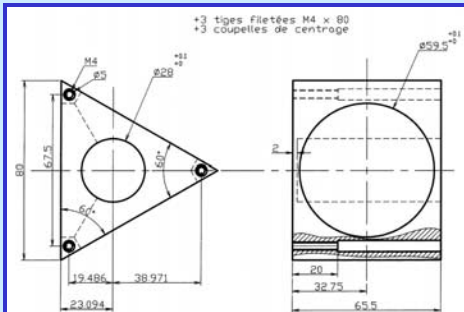

Source and photomultiplier holder

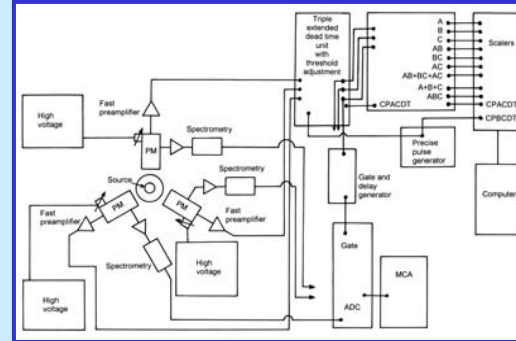

Schematic of experimental set up

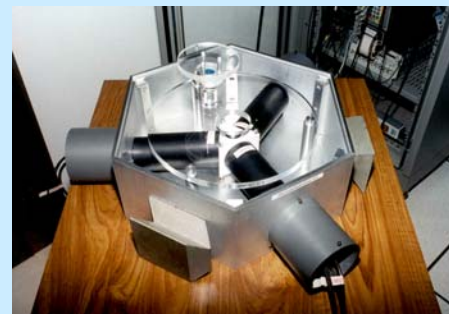

View of the counting set up

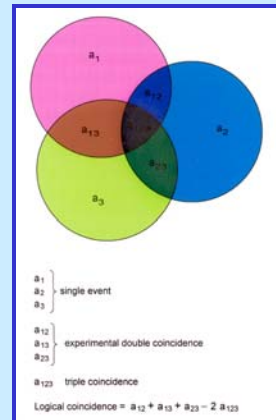

Logical relationship between different number of counts



Inner view of the coincidence unit

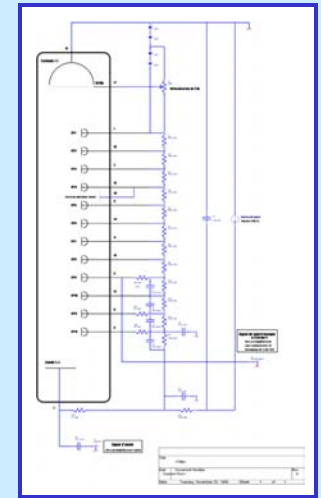

Schematic of a photomultiplier basis

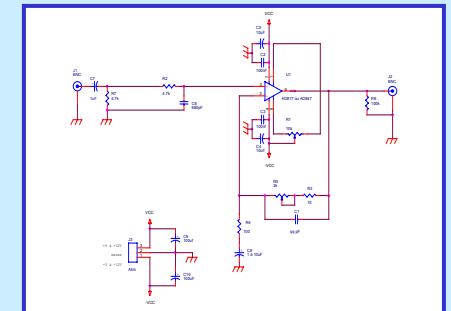

Diagram of a spectrometry preamplifier

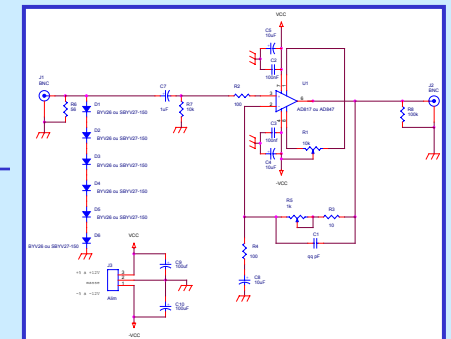

Diagram of an anode preamplifier