

**BUREAU INTERNATIONAL DES POIDS ET MESURES**

**DETERMINATION OF THE DIFFERENTIAL TIME CORRECTIONS  
FOR GPS TIME EQUIPMENT LOCATED AT THE  
OP, NTSC, CRL, NMIJ, TL, and NML**

W. Lewandowski and P. Moussay



2003

Pavillon de Breteuil, F-92312 SEVRES Cedex



## **Abstract**

Following a suggestion at the 4th meeting of the CCTF Working Group on Two-Way Satellite Time Transfer (TWSTFT), the BIPM is conducting a series of differential calibrations of GPS equipment located in time laboratories equipped with two-way stations. This report describes measurements which took place from 8 July to 6 November 2002, involving GPS time equipment located at the Observatoire de Paris (OP, Paris, France), the National Time Service Center of China (NTSC, Lintong, P.R. China), the Communication Research Laboratory (CRL, Tokyo, Japan), the National Metrology Institute of Japan (NMIJ, Tsukuba, Japan), the Telecommunication Laboratories (TL, Chung-Li, Taiwan), and the National Measurement Laboratory (NML, Sydney, Australia).

## **INTRODUCTION**

Following a suggestion at the 4th meeting of the CCDS Working Group on TWSTFT [1], the BIPM is conducting a series of differential calibrations of GPS equipment located in time laboratories equipped with two-way stations [2, 3].

As for previous trips the GPS time equipment located at the OP was chosen as reference: to check the reproducibility of the measurements, the calibrations were organized as round trips beginning and ending at the OP. Although the OP is not yet equipped with a TWSTFT station, it has often served in the past as reference laboratory for GPS calibrations. Over the last twenty years its GPS time receiver has been compared several times with the NIST absolutely-calibrated reference GPS time receiver. The difference between these two has never exceeded a few nanoseconds.

Repeated determinations of the differential time corrections for the GPS time equipment located in the various laboratories should:

- improve the accuracy of the access to UTC of participating laboratories;
- provide valuable information about the stability of GPS time equipment;
- serve as provisional differential calibrations of the two-way equipment at the laboratories.

This report describes an exercise which took place from 8 July to 6 November 2002. Subsequent visits are scheduled to take place approximately annually.

## EQUIPMENT

Details of the receivers involved are provided in Table 1. More information about the set-up of equipment at each location is provided in Appendix I.

**Table 1.** GPS equipment involved in this comparison.

Laboratory	Receiver maker	Receiver type	Receiver ser. no.
OP	AOA	TTR-5	NBS051
NTSC	3S Navigation	R100/30T	0045
CRL (TTR6)	AOA	TTR-6	451
CRL (R100)	3S Navigation	R100/40T	0017
NMIJ	AOA	TTR-6	484
TL	AOA	TTR-6	479
NML	NML/Topcon	Topcon Euro-80	8RQRFKXT534
BIPM Portable receiver	AOS	TTS-2	020

The portable BIPM H receiver is equipped with a C101 cable. Its delay measured at the BIPM is  $(184.34 \pm 0.4)$  ns, where the number following the symbol  $\pm$  is the numerical value of the standard uncertainty ( $1\sigma$ ) and not a confidence interval.

This delay was measured using a double-weight pulse method with a time interval counter steered by an external frequency source (an HP 5071A clock). We measured at the very beginning of the linear part of the rising pulse at each end of the cable using a 0.5 V trigger level [4].

The cable delay was also measured at the visited laboratories, and the results are reported in Appendix II.

## CONDITIONS OF COMPARISON

For the present comparison, the portable equipment comprised the receiver, its antenna and a calibrated antenna cable. The laboratories visited supplied: (a) a 10 MHz reference signal; and (b) a series of 1 s pulses from the local reference,  $UTC(k)$ , via a cable of known delay. In each laboratory the portable receiver was connected to the same clock as the local receiver and the antenna of the portable receiver was placed close to the local antenna. The differential coordinates of the antenna phase centres were known at each site with standard uncertainties ( $1\sigma$ ) of a few centimetres.

## RESULTS

The processing of the comparison data obtained in laboratory  $k$  consists first of computing, for each track  $i$ , the time differences

$$dt_{k,i} = [UTC(k) - GPS\ time]_{BIPMH,i} - [UTC(k) - GPS\ time]_{k,i} .$$

The noise exhibited by the time series  $dt_k$  is then analysed, for each of the laboratories visited, by use of the modified Allan variance. In each case, white phase noise was exhibited up to an averaging interval of about one day. We illustrate this in Figure 1.

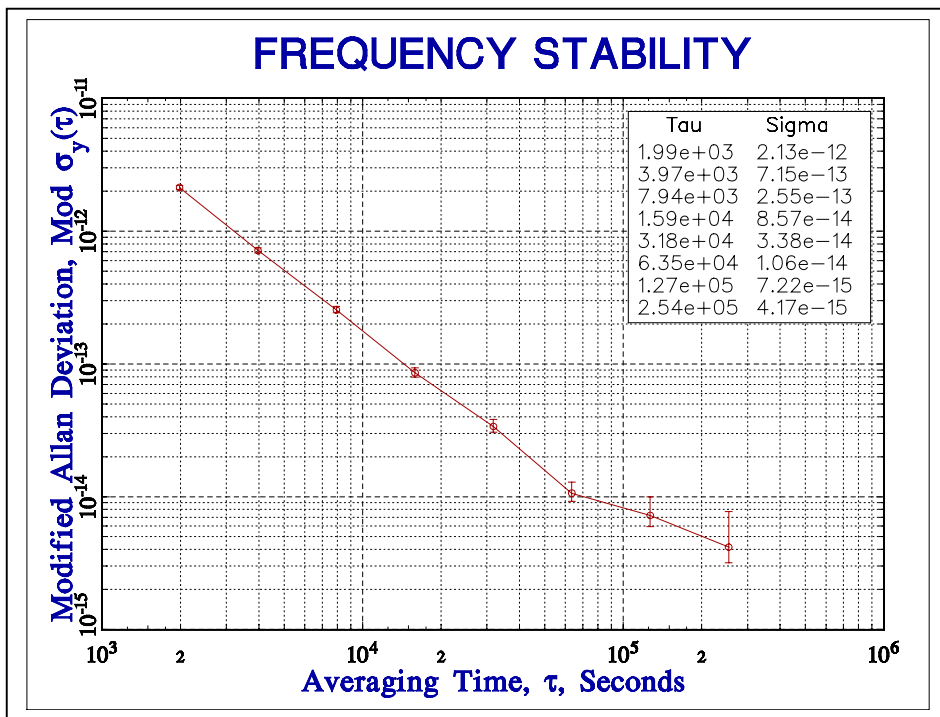

**Figure 1.** Square root of the modified Allan variance of the time series  $dt_{OP}$  for the period: 26 December 2001 to 08 January 2002.

The one-day averages are reported in Figure 2 and Appendix III. The level of noise for a one-day averaging period is reported in Table 2.

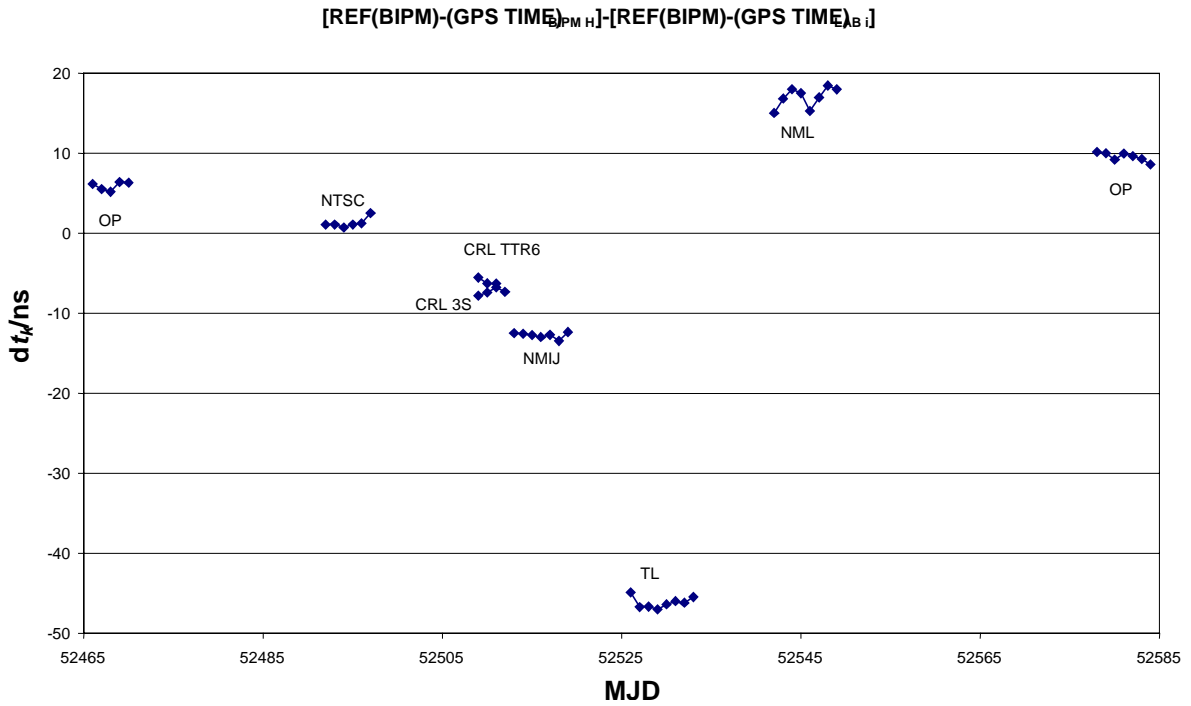

**Figure 2.** Daily averages of  $dt_{k,i}$  for each laboratory (see Appendix III).

Next, we computed mean offsets for the full duration of the comparison at each location, and the corresponding standard deviations of individual common-view observations (see Table 2).

**Table 2.** Mean offsets for the full duration of the comparison at each location.

Lab	Period 2002	Total number of common views	Mean offset /ns	Standard deviation of individual common-view observations/ns	Level of noise for 1 day /ns	Dispersion of daily mean /ns
OP	8–15 July	178	6.0	2.3	0.6	0.5
NTSC	5–11 Aug	1840	1.1	3.6	0.6	0.6
CRL TTR6	16–26 Aug	126	−6.2	4.9	1.0	0.4
CRL R100	16–26 Aug	1231	−7.2	5.0	1.0	0.4
NMIJ	27 Aug–2 Sep	247	−12.7	3.8	0.6	0.4
TL	9–16 Sep	225	−46.3	2.8	0.5	0.7
NML	24 Sep–2 Oct	1797	17.1	3.6	1.0	1.3
OP	31 Oct–6 Nov	261	9.5	3.4	0.6	0.6

The “closure” – the difference between the first and last sets of measurements made at the OP – was within an acceptable range. After averaging the results of the two sets of measurements at the OP, we then derived differential time corrections which should be made (added) to time differences derived during the GPS comparisons of the time scales kept by these laboratories. The results are summarized in Table 3.

**Table 3.** Differential time correction  $d$  to be added to  $[UTC(k_1) - UTC(k_2)]$ , and its estimated uncertainty  $u(d)$  for the period of comparison ( $1 \sigma$ ).

$[UTC(k_1) - UTC(k_2)]$	$d/\text{ns}$	$u(d)/\text{ns}$
$[UTC(\text{NTSC}) - UTC(\text{OP})]$	-7	4
$[UTC(\text{CRLtr6}) - UTC(\text{OP})]$	-14	4
$[UTC(\text{CRLR100}) - UTC(\text{OP})]$	-15	4
$[UTC(\text{NMIJ}) - UTC(\text{OP})]$	-20	4
$[UTC(\text{TL}) - UTC(\text{OP})]$	-54	4
$[UTC(\text{AUS}) - UTC(\text{OP})]$	9	4

The uncertainties given in this table are conservative. They are mainly driven by the uncertainty due to the ‘round-trip’ reproducibility at the OP.

## CONCLUSION

These measurements are part of a series of differential calibrations of GPS equipment located in time laboratories equipped with TWSTFT stations. They provide an independent calibration of TWSTFT equipment and also improve accuracy of the access to UTC of participating laboratories.

The measurements reported were performed under good conditions although with somewhat large closure of the travelling equipment at the OP. In most cases the GPS time equipment of the participating laboratories did not agree with the reference equipment at the OP; the differences reach some tens of nanoseconds. Readjustment of the delays of GPS time equipment in these laboratories might be necessary. It should be stressed that these laboratories are linked to the UTC system through TWSTFT links, which were calibrated by GPS links. The results of this calibration indicate that a new calibration of these TWSTFT links is required.

Repeated calibration trips will be necessary also for monitoring the time equipment delays in these participating laboratories.

## Acknowledgements

The authors wish to express their gratitude to their colleagues at the participating laboratories for the unreserved collaboration they received. Without this, the work could not have been accomplished.

## REFERENCES

- [1] The CCDS Working Group on Two-Way Satellite Time Transfer, *Report of the 4th Meeting*, Turin, October 1996.
- [2] J.A. Davis, P.R. Pearce, D. Kirchner, H. Ressler, P. Hetzel, A. Söring, G. De Jong, F. Baumont, L. Veenstra, "Two-Way Satellite Time Transfer Experiments Between Six European Laboratories Using the INTELSAT (VA-F13) Satellite", *Proc. 8th EFTF*, pp. 296-314, March 1994.
- [3] D. Kirchner, H. Ressler, R. Robnik, "Recent work in the field of two-way satellite time transfer carried out at the TUG", *Proc. 11th EFTF*, pp. 205-208, March 1997.
- [4] G. de Jong, "Measuring the propagation time of coaxial cables used with GPS receivers," *Proc. 17th PTTI*, pp. 223-232, December 1985.

## **Appendix I**

**Set-ups of local and portable equipment at each location  
(forms completed by the participating laboratories)**



## BIPM GPS calibration information sheet

Laboratory:	BNM – SYRTE, Observatoire de Paris	
Date and hour of the beginning of measurements:	8 July 2002 (52463) 10h02	
Date and hour of the end of measurements:	15 July 2002 (52470) 11h58	
<b>Receiver setup information</b>		
	<b>Local: NBS 51</b>	<b>Portable: BIPM H</b>
• Maker:	Allen Osborne Associates	BIPM
• Type:	TTR-5	TTS-2
• Serial number:	051	FR72753545
• Receiver internal delay :	54 ns	-19,36 ns
• Antenna cable identification:	505 IF	C101
Corresponding cable delay :	168 ns $\pm$ 0,3 ns	184,3 ns $\pm$ 0,4 ns
• UTC cable identification:	503	497
Corresponding cable delay :	/	/
Delay to local UTC :	304 ns	306 ns
• Receiver trigger level:	0.5 V	0.5 V
• Coordinates reference frame:	ITRF	ITRF
Latitude:	4 202 780,30 m	4 202 781,970 m
Longitude:	171 370,03 m	171 364,125 m
Height:	4 778 660,12 m	4 778 658,526 m
<b>Antenna information</b>		
	<b>Local:</b>	<b>Portable:</b>
• Maker:	A.O.A.	Matsushita elec. works
• Type:	/	GPS
• Serial number:	/	0709 AU 53022
If the antenna is temperature stabilised		
• Set temperature value :	/	
<b>Local antenna cable information</b>		
• Maker:	/	
• Type:	RG-58	
• Is it a phase stabilised cable:	No	
• Length of cable outside the building :	Approximately 6 meters	
<b>General information</b>		
• Rise time of the local UTC pulse:	4 ns	
• Is the laboratory air conditioned:	Yes	
• Set temperature value and uncertainty :	(21,5 $\pm$ 2) °C	
• Set humidity value and uncertainty :	/	
<b>Cable delay control</b>		
Cable identification	delay measured by BIPM	Delay measured by local method
BIPM C101	184,3 ns $\pm$ 0,4 ns	184,6 ns $\pm$ 0,3 ns

### Plot of the experiment set-up:

Link to the local UTC of both receivers and Antenna positions

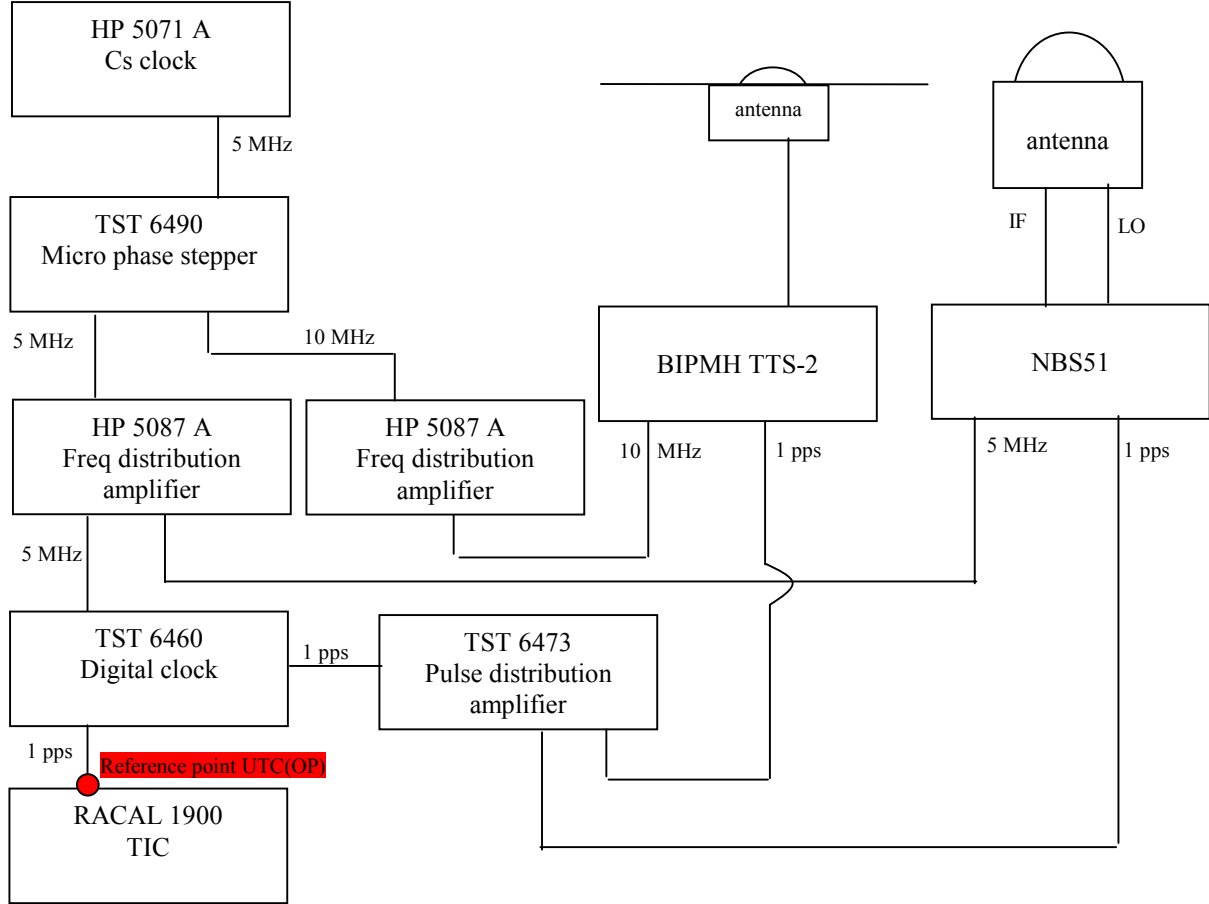

### Description of the local method of cable delay measurement:

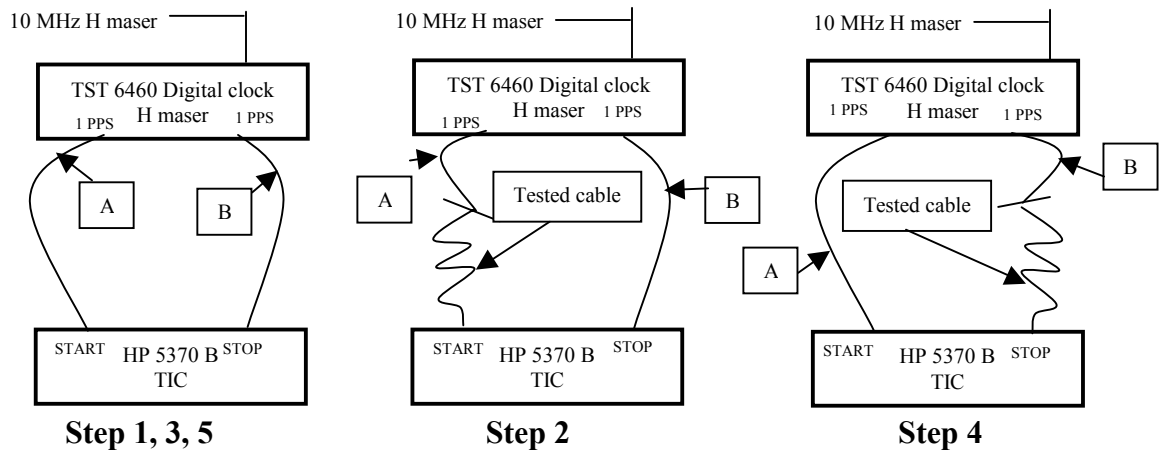

The method used to calibrate the cables is a double weight method in five steps as shown above.

At each step (i) the TIC gives the result ( $R_i$ ) of 100 measurements.

The test cable delay is then obtained by the following formula:

$$\text{Delay} = \frac{R_2 - \left(\frac{R_1 + R_3}{2}\right) + \left(\frac{R_3 + R_5}{2}\right) - R_4}{2} + \text{corrections}$$

The corrections are the estimated delay introduced by adaptors : - 0,1 ns / adaptor

## BIPM GPS calibration information sheet

Laboratory:	NTSC	
Date and hour of the beginning of measurements:	5 August 2002 (52491) 14 <sup>h</sup> 02 <sup>m</sup>	
Date and hour of the end of measurements:	11 August 2002 (52497) 11 <sup>h</sup> 16 <sup>m</sup>	
<b>Receiver setup information</b>		
	Local: NTSC 0045	Portable: BIPM H
• Maker:	3S Navigation	BIPM
• Type:	R100/30T	TTS-2
• Serial number:	0045	FR72753545
• Receiver internal delay (GPS) :	199.8 ns	-19,36 ns
• Receiver internal delay (GLO) :		
• Antenna cable identification:	Non-specified	C101
Corresponding cable delay :	262,26 ± 1,0ns	184,3 ns ± 0,4 ns
• UTC cable identification:	SYV-50-3	SYV-50-3
Corresponding cable delay :		15.5 ns
Delay to local UTC :	8,8 ns	15,58 ns
• Receiver trigger level:	0,5 V	0.5 V
• Coordinates reference frame:	ITRF	ITRF
Latitude or X m	-1735231.87 m	-1735232.87 m
Longitude or Y m	+4976846.80 m	4976844.75 m
Height or Z m	+3580529.00 m	3580530.92 m
<b>Antenna information</b>		
	Local:	Portable:
• Maker:	3S Navigation	Matsushita elec. works
• Type:	TSA-100	GPS
• Serial number:		0709 AU 53022
If the antenna is temperature stabilised YES		
• Set temperature value :	23.9°C/Cooler and 40.5° C/Heater	
<b>Local antenna cable information</b>		
• Maker:	/	
• Type:	/	
• Is it a phase stabilised cable:	No	
• Length of cable outside the building :	About 8 meters	
<b>General information</b>		
• Rise time of the local UTC pulse:	8.8 ns	
• Is the laboratory air conditioned:	yes	
• Set temperature value and uncertainty :	22.6 ± 0.2°C	
• Set humidity value and uncertainty :	55.1% ± 2.7%	
<b>Cable delay control</b>		
Cable identification	delay measured by BIPM	Delay measured by local method
BIPM C101	184,34 ns ± 0,4 ns	183.75 ns ± 0.01 ns

### Plot of the experiment set-up:

Link to the local UTC of both receivers and Antenna positions

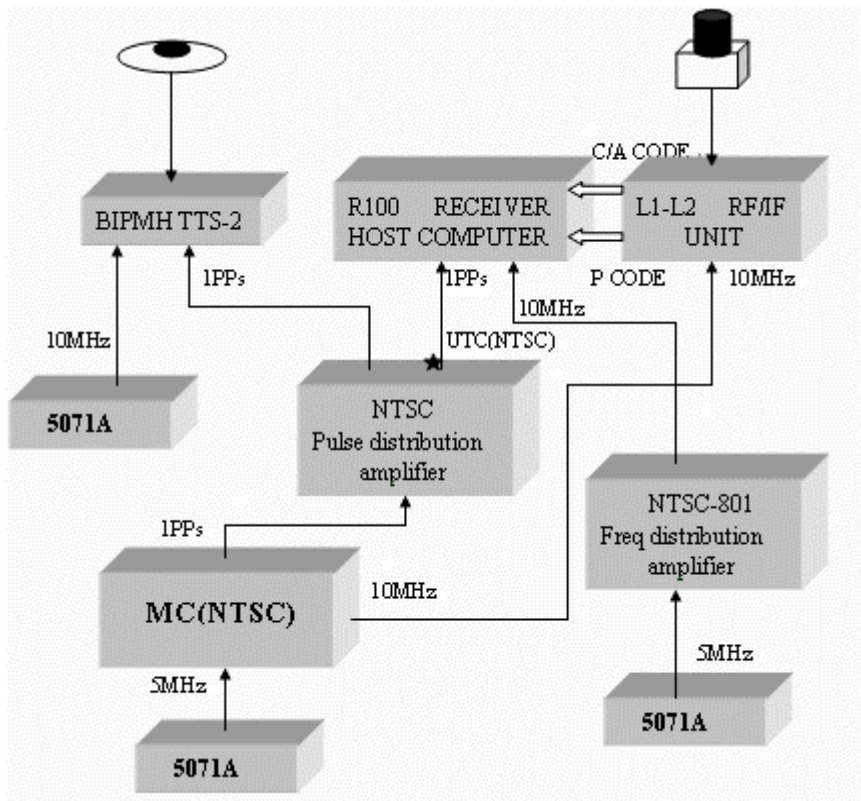

### Description of the local method of cable delay measurement:

- R1, the average of 20 TIC readings of differences between two pulses from the same source.
- R2, the average of those as a) with cable under test in Stop-Input of TIC.
- CAB Delay = R2 - R1.

## BIPM GPS calibration information sheet

Laboratory:		CRL TOKYO JAPAN		
Date and hour of the beginning of measurements:		16 Aug. 2002 (MJD 52502) UTC:01h50m15s		
Date and hour of the end of measurements:		26 Aug. 2002 (MJD 52512) UTC:00h38m00s		
<b>Receiver setup information</b>				
	<b>Local:</b> TTR6□□□□	<b>Local:R100</b>	<b>Portable: BIPM H</b>	
• Maker:	AOA□	3S Navigation	BIPM	
• Type:	TTR-6	R100 40T	TTS-2	
• Serial number:	451	0017	FR72753545	
• Receiver internal delay (GPS) :	44.8ns	333.0ns	-19,36 ns	
• Receiver internal delay (GLO) :		134.0ns		
• Antenna cable identification:	TTR6(219.6ns)	R100a(204.0ns)	C101	
Corresponding cable delay :	250.0ns	204.0ns	184,3 ns ± 0,4 ns	
• UTC cable identification:	GPS G	UTC(CRL)1pps D2	UTC(CRL)1pps D1	
Corresponding cable delay :	□□			
Delay to local UTC :	Header Value	316.1ns	415.5ns	
	Meas. Value	304.9ns	325.6ns	324.9ns
• Receiver trigger level:	0.5V	0.5V	0.5 V	
• Coordinates reference frame:	WGS-84	WGS-84	WGS-84	
Latitude or X m	-3942161.90m	-3942160.08m	-3942162.97m	
Longitude or Y m	3368284.20m	3368286.24m	3368282.20m	
Height or Z m	3701886.69m	3701887.32m	3701886.59m	
<b>Antenna information</b>				
	<b>Local: TTR6</b>	<b>Local:R100</b>	<b>Portable:</b>	
• Maker:	AOA	3S Navigation	Matsushita elec. works	
• Type:		TSA-100	GPS	
• Serial number:	449(Down Converter)	0010	0709 AU 53022	
If the antenna is temperature stabilised				
• Set temperature value :		Heater 105°F Cooler 75°F		
<b>Local antenna cable information</b>				
• Maker:				
• Type:	RG58AU	RG214/U		
• Is it a phase stabilised cable:	No	No	No	
• Length of cable outside the building :	Approx. 18 m	Approx. 18 m	Approx. 18 m	
<b>General information</b>				
• Rise time of the local UTC pulse:	4.7ns(10%-90%)pulse height 4.59v DC			
• Is the laboratory air conditioned:	YES			
• Set temperature value and uncertainty :	GPS RX Room□23□±2□			
• Set humidity value and uncertainty :	N/A			
<b>Cable delay control</b>				
Cable identification	delay measured by BIPM		Delay measured by local method	
BIPM C101	184,34 ns ± 0,4 ns		184.41 ns : by <a href="mailto:TI-Counter@lpps">TI-Counter@lpps</a> 182.69 ns : by <a href="mailto:Agilent8720ES@1.22760GHz">Agilent8720ES@1.22760GHz</a> 182.71 ns : by <a href="mailto:Agilent8720ES@1.57542GHz">Agilent8720ES@1.57542GHz</a>	

### Plot of the experiment set-up:

Link to the local UTC of both receivers and Antenna positions

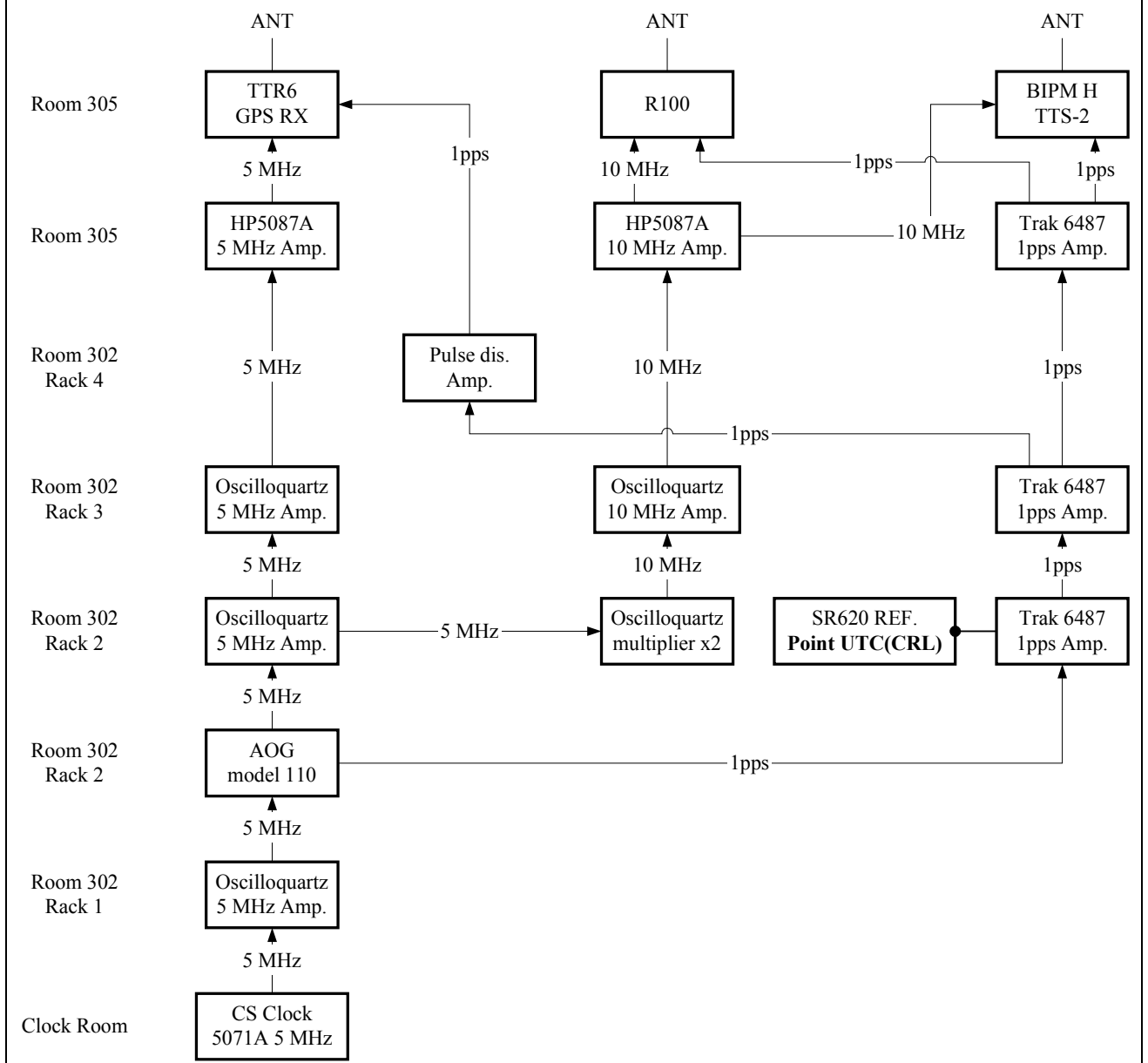

### Description of the local method of cable delay measurement:

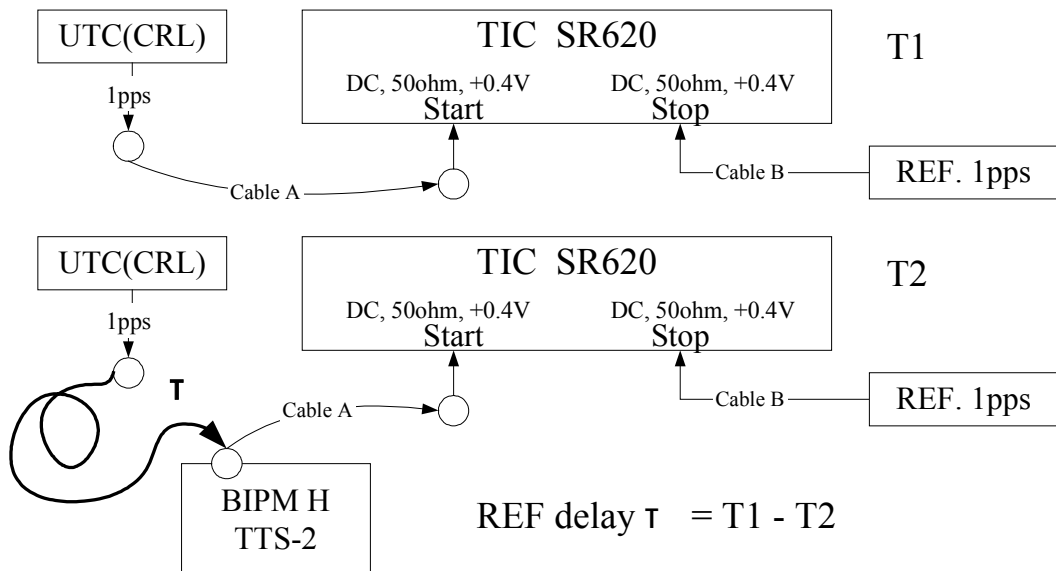

## BIPM GPS calibration information sheet

Laboratory:	National Metrology Institute of Japan (NMIJ)	
Date and hour of the beginning of measurements:	2002 Aug. 27 5:00	
Date and hour of the end of measurements:	2002 Sep. 2 1:00	
<b>Receiver setup information</b>		
	<b>Local:</b>	<b>Portable: BIPM H</b>
• Maker:	Allen Osborne Associates	BIPM
• Type:	TTR-6	TTS-2
• Serial number:	484	FR72753545
• Receiver internal delay (GPS) :	50 ns	-19,36 ns
• Receiver internal delay (GLO) :		
• Antenna cable identification:		C101
Corresponding cable delay :	259 ns	184,3 ns $\pm$ 0,4 ns
• UTC cable identification:		
Corresponding cable delay :	14 ns	49.6 ns
Delay to local UTC :	136 ns	187.9 ns
• Receiver trigger level:		0.5 V
• Coordinates reference frame:	ITRF94	ITRF94
Latitude or X m	-3962298.00	-3962299.52
Longitude or Y m	3308877.62	3308876.76
Height or Z m	3733535.02	3733532.03
<b>Antenna information</b>		
	<b>Local:</b>	<b>Portable:</b>
• Maker:	Allen Osborne Associates	Matsushita elec. works
• Type:	GPS	GPS
• Serial number:	682	0709 AU 53022
If the antenna is temperature stabilised		
• Set temperature value :		
<b>Local antenna cable information</b>		
• Maker:	FUJIKURA	
• Type:	RG-58A/U / RG 55/U (two types are connected)	
• Is it a phase stabilised cable:		
• Length of cable outside the building :	About 15 m	
<b>General information</b>		
• Rise time of the local UTC pulse:	3.7 ns	
• Is the laboratory air conditioned:	Yes	
• Set temperature value and uncertainty :	23 degC	uncertainty: 1degC
• Set humidity value and uncertainty :	60%	uncertainty: 10%
<b>Cable delay control</b>		
Cable identification	delay measured by BIPM	Delay measured by local method
BIPM C101	184,34 ns $\pm$ 0,4 ns	189.6 ns

### Plot of the experiment set-up:

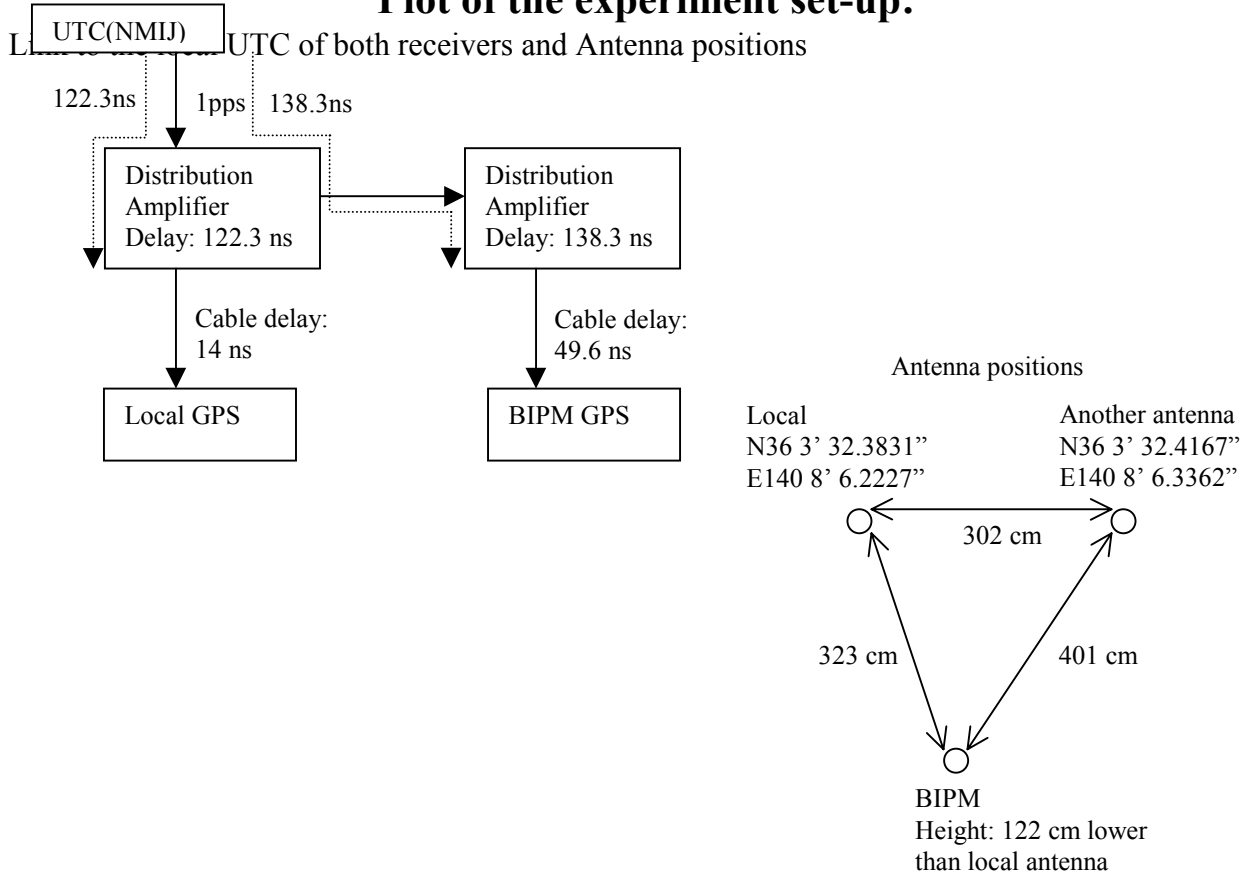

### Description of the local method of cable delay measurement:

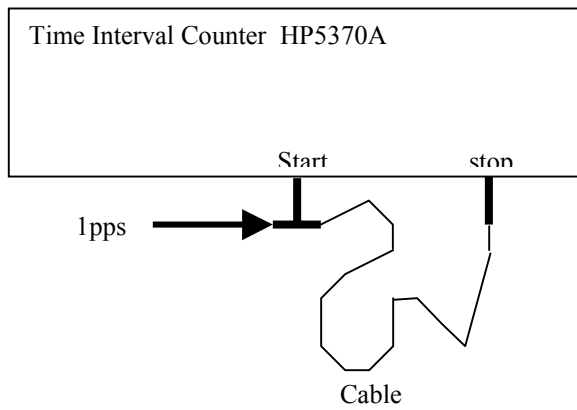

## BIPM GPS calibration information sheet

Laboratory:	NML (Sydney, Australia)	
Date and hour of the beginning of measurements:	24/09/02 (MJD 52542) 04:14 UTC	
Date and hour of the end of measurements:	02/10/02 (MJD 52549) 00:50 UTC	
<b>Receiver setup information</b>		
	Local:	Portable: BIPM H
• Maker:	NML/Topcon	BIPM
• Type:	Topcon Euro-80	TTS-2
• Serial number:	8RQRFKXT534	FR72753545
• Receiver internal delay (GPS) :	46.5 ns nominal (uncalibrated)	-19,36 ns
• Receiver internal delay (GLO) :		
• Antenna cable identification:	TCDF-1	C101
Corresponding cable delay :	75.9 ns $\pm$ 1 ns	184,3 ns $\pm$ 0,4 ns
• UTC cable identification:	UTC(AUS) 9/1/02	BIPM
Corresponding cable delay :	76.0 ns $\pm$ 1 ns	24.76 ns $\pm$ 1 ns
Delay to local UTC :	76.0 ns $\pm$ 1 ns	24.76 ns $\pm$ 1 ns
• Receiver trigger level:	0.5 V	0.5 V
• Coordinates reference frame:	ITRF 2000	ITRF 2000
Latitude or X m	-4 648 200.294	-4 648 198.199
Longitude or Y m	2 560 484.056	2 560 482.139
Height or Z m	-3 526 505.254	-3 526 509.320
<b>Antenna information</b>		
	Local:	Portable:
• Maker:	Topcon	Matsushita elec. works
• Type:	Regant-1	GPS
• Serial number:	RA0122	0709 AU 53022
If the antenna is temperature stabilised		
• Set temperature value :	N/A	N/A
<b>Local antenna cable information</b>		
• Maker:	Rojone	
• Type:	LMR400	
• Is it a phase stabilised cable:	No	
• Length of cable outside the building :	14 m	
<b>General information</b>		
• Rise time of the local UTC pulse:	2.5 ns [10%–90%, using a 2 GHz CRO]	
• Is the laboratory air conditioned:	Yes	
• Set temperature value and uncertainty :	(19.5 $\pm$ 1.0) °C [measured range over calibration]	
• Set humidity value and uncertainty :	(50 $\pm$ 10) %	
<b>Cable delay control</b>		
Cable identification	delay measured by BIPM	Delay measured by local method
BIPM C101	184,34 ns $\pm$ 0,4 ns	183.94 ns $\pm$ 1 ns

## Plot of the experiment set-up:

Link to the local UTC of both receivers and Antenna positions

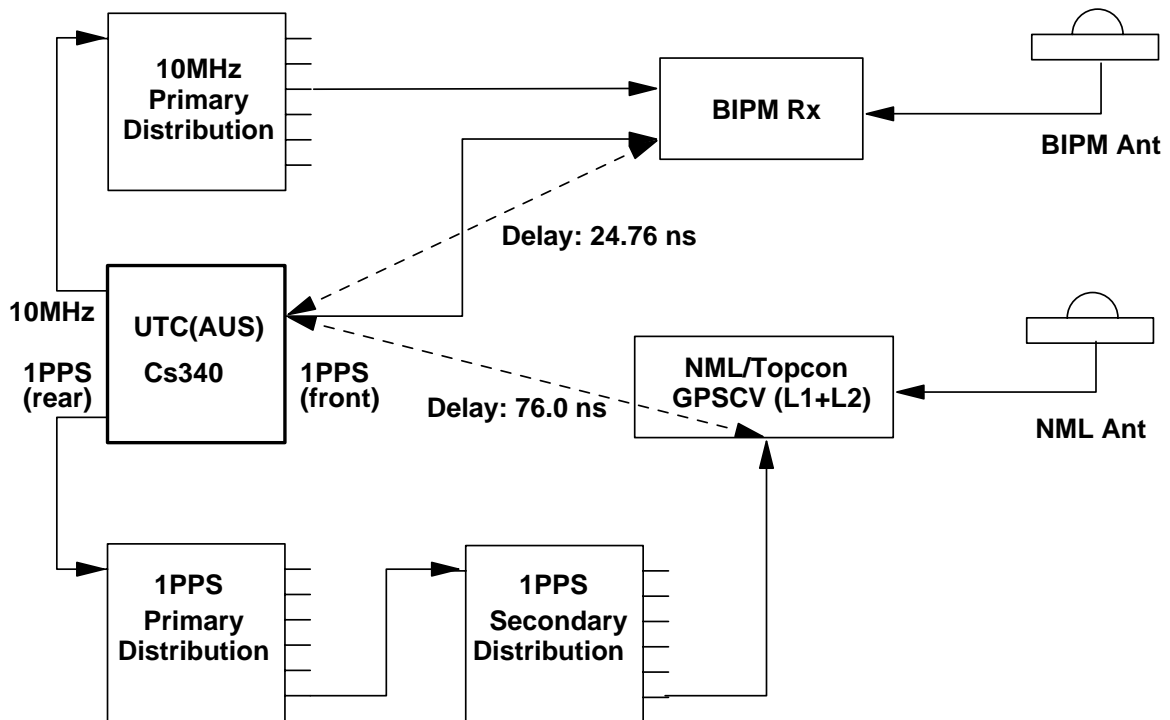

The epoch of UTC(AUS) is defined as the epoch at which the 1pps pulse exits the front panel of Cs 340, and all cable delays are measured relative to this point.

## Description of the local method of cable delay measurement:

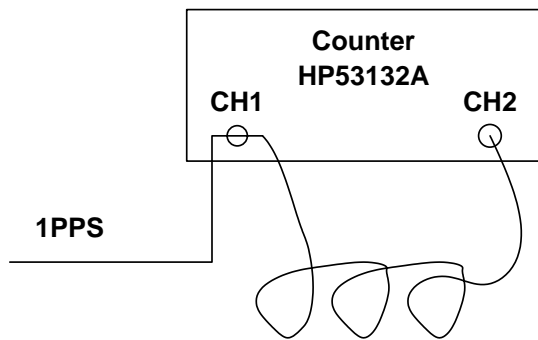

**Cable to be measured**

	CH1	CH2
Trigger	0.5V	0.5V
Termination	1 M $\Omega$	50 $\Omega$

**Mode: Time interval Ch1 to Ch2**

The counter is externally referenced to Cs 340 via 10 MHz secondary distribution. The delay of the C101 antenna cable was measured with a TNC-to-BNC adapter added to each end of the cable.

Values reported for cable delays are the mean of 100 measurements, as calculated by the counter. The typical standard deviation of these measurements is 0.1ns. However, we observe a typical day-to-day variation of up to  $\pm 0.5$  ns in the delay measured for a given cable, and we therefore estimate the uncertainty of this measurement method at  $\pm 1$  ns.

## BIPM GPS calibration information sheet

Laboratory: BNM-SYRTE (ex LPTF)	BIPM	
Date and hour of the beginning of measurements:	52578 - 09 h 18 min UTC	
Date and hour of the end of measurements:	52584 - 08 h 06 min UTC	
<b>Receiver setup information</b>		
	Local: NBS 51	Portable: BIPM H
• Maker:	Allen Osborne Associates	BIPM
• Type:	TTR-5	TTS-2
• Serial number:	051	FR72753545
• Receiver internal delay :	54 ns	-19,36 ns
• Antenna cable identification:	505 IF	C101
Corresponding cable delay :	168 ns $\pm$ 0,3 ns	184,3 ns $\pm$ 0,4 ns
• UTC cable identification:	503	497
Corresponding cable delay :	/	/
Delay to local UTC :	304 ns	306 ns
• Receiver trigger level:	0.5 V	0.5 V
• Coordinates reference frame:	ITRF	ITRF
Latitude:	4 202 780,30 m	4 202 781,970 m
Longitude:	171 370,03 m	171 364,125 m
Height:	4 778 660,12 m	4 778 658,526 m
<b>Antenna information</b>		
	Local:	Portable:
• Maker:	A.O.A.	Matsushita elec. works
• Type:	/	GPS
• Serial number:	/	0709 AU 53022
If the antenna is temperature stabilised		
• Set temperature value :	/	
<b>Local antenna cable information</b>		
• Maker:	/	
• Type:	RG-58	
• Is it a phase stabilised cable:	No	
• Length of cable outside the building :	Approximately 6 meters	
<b>General information</b>		
• Rise time of the local UTC pulse:	4 ns	
• Is the laboratory air conditioned:	Yes	
• Set temperature value and uncertainty :	(21,5 $\pm$ 2) °C	
• Set humidity value and uncertainty :	/	
<b>Cable delay control</b>		
Cable identification	delay measured by BIPM	Delay measured by local method
BIPM C101	184,3 ns $\pm$ 0,4 ns	184,3 ns $\pm$ 0,3 ns

### Plot of the experiment set-up:

Link to the local UTC of both receivers and Antenna positions

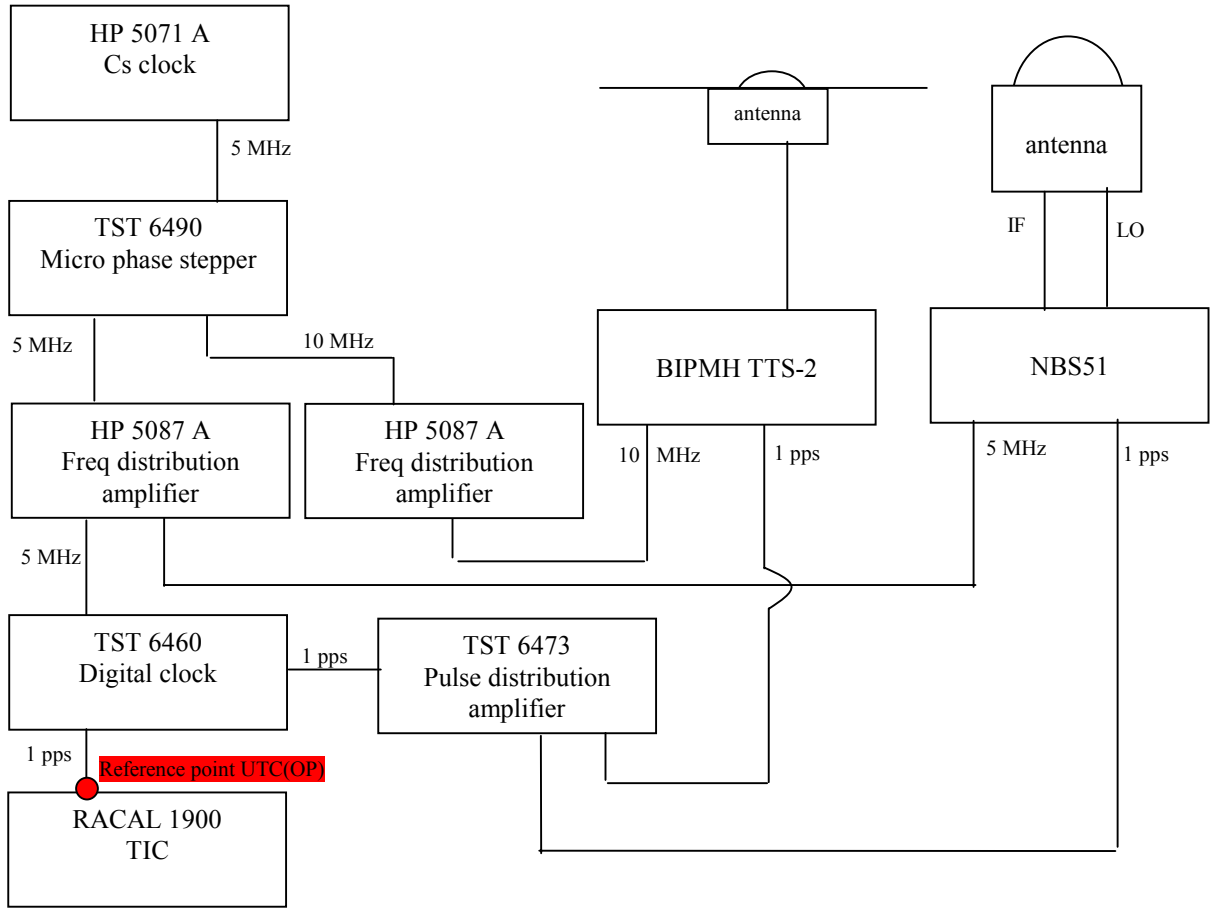

### Description of the local method of cable delay measurement:

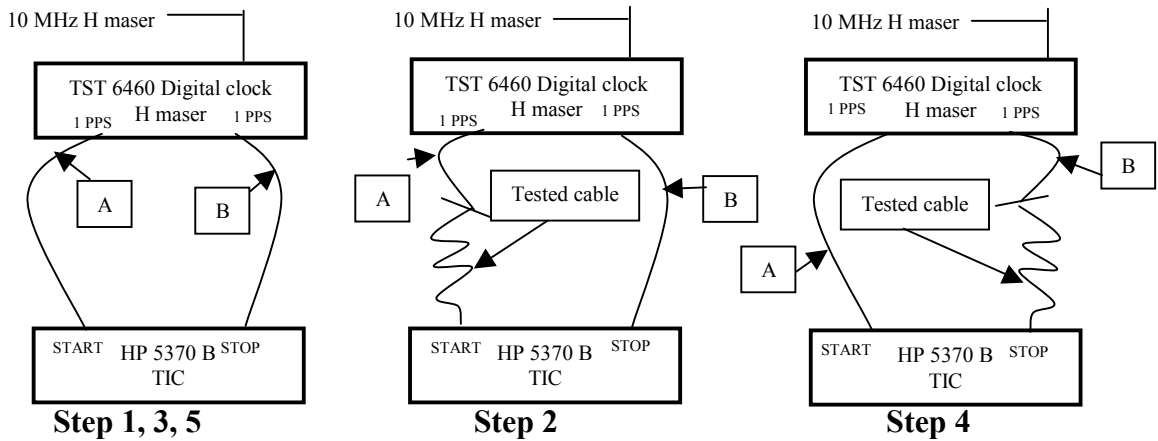

The method used to calibrate the cables is a double weight method in five steps as shown above.

At each step (i) the TIC gives the result ( $R_i$ ) of 100 measurements.

The test cable delay is then obtained by the following formula:

$$\text{Delay} = \frac{R_2 - \left(\frac{R_1 + R_3}{2}\right) + \left(\frac{R_3 + R_5}{2}\right) - R_4}{2} + \text{corrections}$$

The corrections are the estimated delay introduced by adaptors : - 0,1 ns / adaptor

## Appendix II

### Measurement of portable cables at the visited laboratories

Laboratory	BIPM C101 cable delay /ns	Measurement method
BIPM	184.34 $\pm$ 0.4	Double-weight pulse method
OP (before trip)	184.6 $\pm$ 0.3	Dual-weighting method
NTSC	183.7 $\pm$ 0.01	TIC method
CRL	184.4 182.69; 182.71	TIC method Network analyser at GPS freq.
NMIJ	189.6	TIC method
TL	183.3 $\pm$ 0.5	Network analyser
NML	183.94 $\pm$ 1.0	TIC method
OP (after trip)	184.3 $\pm$ 0.3	Dual-weighting method

**Note.** The number following the symbol  $\pm$  is the numerical value of the standard uncertainty ( $1\sigma$ ) and not a confidence interval.

**Appendix III**  
**Daily results of the comparisons**

LAB	MJD	Mean offset /ns	Standard deviation of individual common-view observations /ns	Standard deviation of the mean /ns	Number of individual common views
OP	52466	6.17	2.51	0.48	27
	52467	5.51	2.7	0.41	44
	52468	5.19	2.64	0.4	44
	52469	6.42	2.47	0.37	45
	52470	6.33	2.05	0.45	21
NTSC	52492	1.09	3.92	0.21	344
	52493	1.1	4.07	0.21	362
	52494	0.73	3.72	0.2	353
	52495	1.1	3.57	0.2	335
	52496	1.26	3.39	0.18	346
	52497	2.53	4.02	0.38	114
CRL TTR6	52509	-5.54	5.34	0.88	37
	52510	-6.25	4.52	0.68	44
	52511	-6.27	4.84	0.75	42
CRL R100	52509	-7.79	5.46	0.29	359
	52510	-7.38	5.05	0.26	387
	52511	-6.75	5.27	0.24	479
	52512	-7.32	6.79	1.65	17
NMIJ	52513	-12.48	3.31	0.57	34
	52514	-12.58	4.64	0.72	41
	52515	-12.72	3.94	0.61	42
	52516	-12.97	3.79	0.58	42
	52517	-12.7	3.47	0.52	44
	52518	-13.45	5.21	0.81	41
	52519	-12.35	1.54	0.77	4
TL	52526	-44.9	2.11	0.41	27
	52527	-46.71	2.66	0.48	31
	52528	-46.67	2.66	0.46	33
	52529	-47.01	3.36	0.59	32
	52530	-46.38	2.15	0.4	29
	52531	-45.99	2.73	0.48	32
	52532	-46.2	2.8	0.49	33
	52533	-45.46	4.44	1.57	8
NML	52542	15.04	4.1	0.26	250
	52543	16.85	4.64	0.28	284
	52544	18.01	4.15	0.25	282
	52545	17.52	4.44	0.27	274
	52546	15.3	4.23	0.29	212
	52547	17	5.14	0.31	270
	52548	18.46	4.65	0.29	262
	52549	18	5.6	1.45	15
OP	52578	10.17	3.72	0.69	29
	52579	10	3.48	0.51	46
	52580	9.21	2.72	0.41	44
	52581	9.97	4.39	0.66	44
	52582	9.66	4.49	0.67	45
	52583	9.31	3.01	0.46	43
	52584	8.59	2.96	0.82	13