

BUREAU INTERNATIONAL DES POIDS ET MESURES

DETERMINATION OF THE DIFFERENTIAL TIME CORRECTIONS
FOR GPS TIME EQUIPMENT LOCATED AT THE
OP, NPL, VSL and OCA

W. Lewandowski and P. Moussay



2003

Pavillon de Breteuil, F-92312 SEVRES Cedex

Abstract

Following a suggestion at the 4th meeting of the CCTF Working Group on Two-Way Satellite Time Transfer (TWSTFT), the BIPM is conducting a series of differential calibrations of GPS equipment located in time laboratories equipped with two-way stations. This report describes measurements which took place from 22 May to 15 July 2002, involving GPS time equipment located at the Observatoire de Paris (OP, Paris, France), the National Physical Laboratory (NPL, Teddington, United Kingdom), the Netherlands Meetinstituut, Van Swinden Laboratorium (NMI-VSL, Delft, the Netherlands), and the Observatoire de la Côte d'Azur (OCA, Grasse, France).

INTRODUCTION

Following a suggestion at the 4th meeting of the CCDS Working Group on TWSTFT [1], the BIPM is conducting a series of differential calibrations of GPS equipment located in time laboratories equipped with two-way stations [2, 3].

As for previous trips the GPS time equipment located at the OP was chosen as reference: to check the reproducibility of the measurements, the calibrations were organized as round trips beginning and ending at the OP. Although the OP was not equipped with a TWSTFT station at the period of calibration, it has often served in the past as reference laboratory for GPS calibrations. Over the last twenty years its GPS time receiver has been compared several times with the NIST absolutely-calibrated reference GPS time receiver. The difference between these two has never exceeded a few nanoseconds.

Repeated determinations of the differential time corrections for the GPS time equipment located in the various laboratories should:

- improve the accuracy of the access to UTC of participating laboratories;
- provide valuable information about the stability of GPS time equipment;
- serve as provisional differential calibrations of the two-way equipment at the laboratories.

This report describes an exercise which took place from 22 May to 15 July 2002. Subsequent visits are scheduled to take place at several months intervals.

EQUIPMENT

Details of the receivers involved are provided in Table 1. More information about the set-up of equipment at each location is provided in Appendix I.

Table 1. GPS equipment involved in this comparison.

Laboratory	Receiver maker	Receiver type	Receiver ser. No.
OP	AOA	TTR-5	NBS051
NPL	TFS	TFS receiver	TFS10I
VSL (01)	VSL	prototype	VSL01
VSL (R100)	3S Navigation	R100/40T	0018
OCA	AOA	TTR-5	NBS07
BIPM portable receiver	AOS	TTS-2	020

The portable BIPM H receiver is equipped with a C101 cable. Its delay measured at the BIPM is 184.34 ns with standard deviation of 0.4 ns.

This delay was measured using a double-weight pulse method with a time interval counter steered by an external frequency source (an HP 5071A clock). We measured at the very beginning of the linear part of the rising pulse at each end of the cable using a 0.5 V trigger level [4].

The cable delay was also measured at the visited laboratories, and the results are reported in Appendix II.

CONDITIONS OF COMPARISON

For the present comparison, the portable equipment comprised the receiver, its antenna and a calibrated antenna cable. The laboratories visited supplied: (a) a 10 MHz reference signal; and (b) a series of 1 s pulses from the local reference, UTC(*k*), via a cable of known delay. In each laboratory the portable receiver was connected to the same clock as the local receiver and the antenna of the portable receiver was placed close to the local antenna. The differential coordinates of the antenna phase centres were known at each site with standard uncertainties (1σ) of a few centimetres.

RESULTS

The processing of the comparison data obtained in laboratory k consists first of computing, for each track i , the time differences

$$dt_{k,i} = [UTC(k) - GPS\ time]_{BIPMH,i} - [UTC(k) - GPS\ time]_{k,i} .$$

The noise exhibited by the time series dt_k is then analysed, for each of the laboratories visited, by use of the modified Allan variance. In each case, white phase noise was exhibited up to an averaging interval of about one day. We illustrate this in Figure 1.

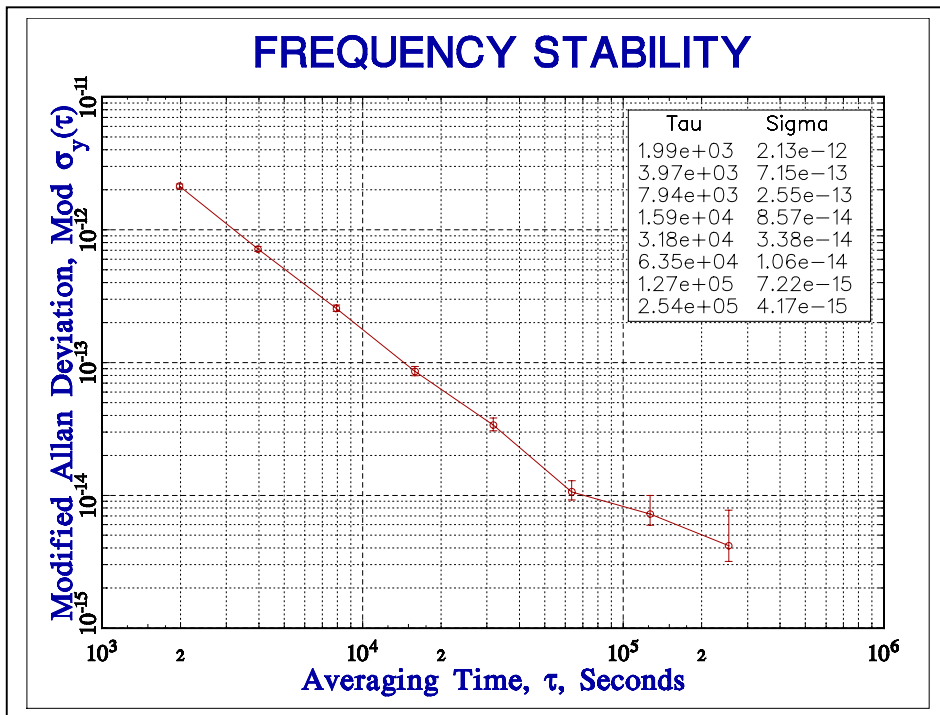

Figure 1. Square root of the modified Allan variance of the time series dt_{OP} for the period: 26 December 2001 to 08 January 2002.

The one-day averages are reported in Figure 2 and Appendix III. The level of noise for a one-day averaging period is reported in Table 2.

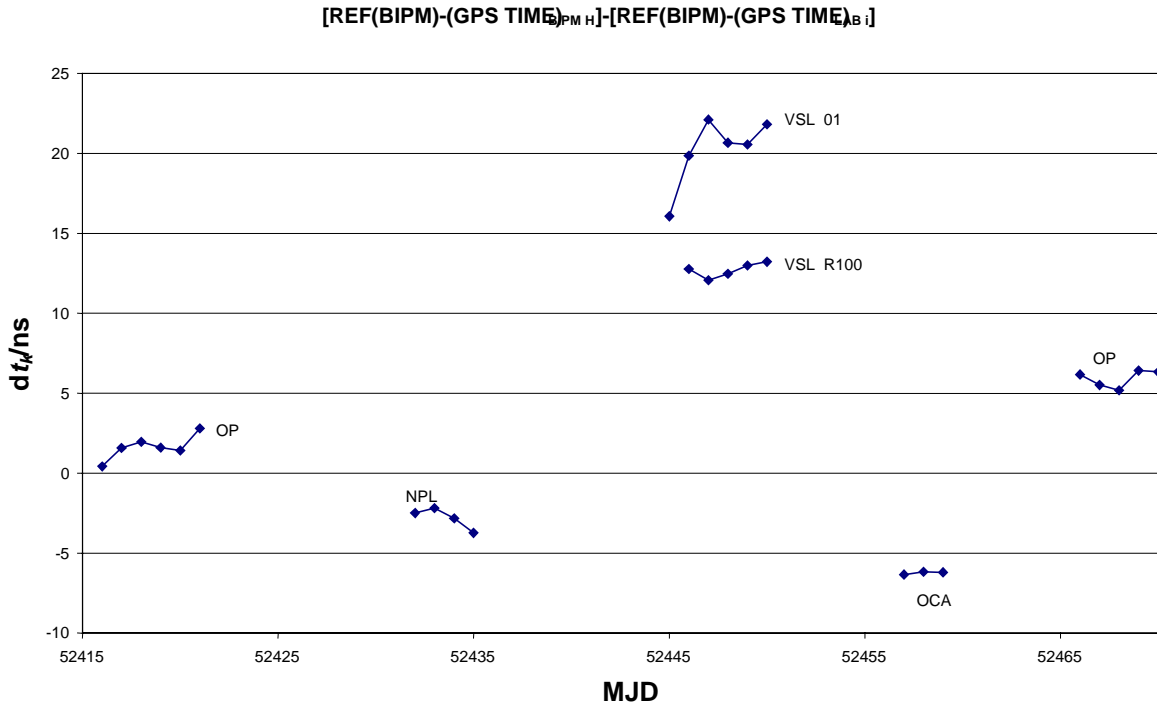

Figure 2. Daily averages of $dt_{k,i}$ for each laboratory (see Appendix III).

Next, we computed mean offsets for the full duration of the comparison at each location, and the corresponding standard deviations of individual common view measurements (see Table 2).

Table 2. Mean offsets for the full duration of the comparison at each location.

Lab	Period 2002	Total number of common views	Mean offset /ns	Standard deviation of individual common-view observations/ns	Level of noise for 1 day /ns	Dispersion of daily mean /ns
OP	22–27 May	213	1.6	2.7	0.5	0.8
NPL	7–17 June	1307	-2.5	2.8	0.4	0.7
VSL 01	20–25 June	202	20.2	3.0	0.5	2.2
VSL R100	20–25 June	1606	12.8	3.9	0.9	0.5
OCA	1–4 July	100	-6.3	1.5	0.3	0.1
OP	8–15 July	178	6.0	2.3	0.6	0.5

The “closure” – the difference between the first and last sets of measurements made at the OP – was somewhat large. The reason for this is not known. After averaging the results of the two sets of measurements at the OP, we then derived differential time corrections which should be made (added) to the time differences derived during the GPS comparisons of the time scales kept by these laboratories. The results are summarized in Table 3.

Table 3. Differential time correction d to be added to $[UTC(k_1) - UTC(k_2)]$, and its estimated uncertainty $u(d)$ for the period of comparison (1σ).

$[UTC(k_1) - UTC(k_2)]$	d/ns	$u(d)/ns$
$[UTC(NPL) - UTC(OP)]$	-6	4
$[UTC(VSL01) - UTC(OP)]$	16	4
$[UTC(VSLR100) - UTC(OP)]$	9	4
$[UTC(OCA) - UTC(OP)]$	-10	4

The uncertainties given in this table are conservative. They are mainly driven by the uncertainty due to the ‘round-trip’ reproducibility at the OP.

CONCLUSION

The measurements reported were performed under good conditions although with somewhat large closure of the travelling equipment at the OP.

The GPS time equipment of the participating laboratories do not agree with the reference equipment at the OP. The differences exceed the uncertainty of this calibration. In these laboratories readjustment of the delays of the GPS time equipment might be considered. It should be stressed that these laboratories are linked to the UTC system through TWSTFT links, which were calibrated by GPS links. The results of this calibration implies a new calibration of involved TWSTFT links.

Repeated calibration trips will be necessary for monitoring the time equipment delays in these participating laboratories.

Acknowledgements

The authors express their gratitude to their colleagues at the participating laboratories for the unreserved collaboration they received. Without this, the work could not have been accomplished.

REFERENCES

- [1] The CCDS Working Group on Two-Way Satellite Time Transfer, *Report of the 4th Meeting*, Turin, October 1996.
- [2] J.A. Davis, P.R. Pearce, D. Kirchner, H. Ressler, P. Hetzel, A. Söring, G. De Jong, F. Baumont, L. Veenstra, "Two-Way Satellite Time Transfer Experiments Between Six European Laboratories Using the INTELSAT (VA-F13) Satellite", *Proc. 8th EFTF*, pp. 296-314, March 1994.
- [3] D. Kirchner, H. Ressler, R. Robnik, "Recent work in the field of two-way satellite time transfer carried out at the TUG", *Proc. 11th EFTF*, pp. 205-208, March 1997.
- [4] G. de Jong, "Measuring the propagation time of coaxial cables used with GPS receivers," *Proc. 17th PTI*, pp. 223-232, December 1985.

Appendix I

**Set-up of local and portable equipment at each location
(forms completed by the participating laboratories)**

BIPM GPS calibration information sheet

Laboratory:	BNM – SYRTE, Observatoire de Paris	
Date and hour of the beginning of measurements:	22 May 2002 (52416) 16h38	
Date and hour of the end of measurements:	27 May 2002 (52421) 08h18	
Receiver setup information		
	Local: NBS 51	Portable: BIPM H
• Maker:	Allen Osborne Associates	BIPM
• Type:	TTR-5	TTS-2
• Serial number:	051	FR72753545
• Receiver internal delay :	54 ns	-19,36 ns
• Antenna cable identification:	505 IF	C101
Corresponding cable delay :	168 ns \pm 0,3 ns	184,3 ns \pm 0,4 ns
• UTC cable identification:	503	497
Corresponding cable delay :	/	/
Delay to local UTC :	304 ns	306 ns
• Receiver trigger level:	0.5 V	0.5 V
• Coordinates reference frame:	ITRF	ITRF
Latitude:	4 202 780,30 m	4 202 781,970 m
Longitude:	171 370,03 m	171 364,125 m
Height:	4 778 660,12 m	4 778 658,526 m
Antenna information		
	Local:	Portable:
• Maker:	A.O.A.	Matsushita elec. works
• Type:	/	GPS
• Serial number:	/	0709 AU 53022
If the antenna is temperature stabilised		
• Set temperature value :	/	
Local antenna cable information		
• Maker:	/	
• Type:	RG-58	
• Is it a phase stabilised cable:	No	
• Length of cable outside the building :	Approximately 6 meters	
General information		
• Rise time of the local UTC pulse:	4 ns	
• Is the laboratory air conditioned:	Yes	
• Set temperature value and uncertainty :	(21,5 \pm 2) °C	
• Set humidity value and uncertainty :	/	
Cable delay control		
Cable identification	delay measured by BIPM	Delay measured by local method
BIPM C101	184,3 ns \pm 0,4 ns	184,6 ns \pm 0,3 ns

Plot of the experiment set-up:

Link to the local UTC of both receivers and Antenna positions

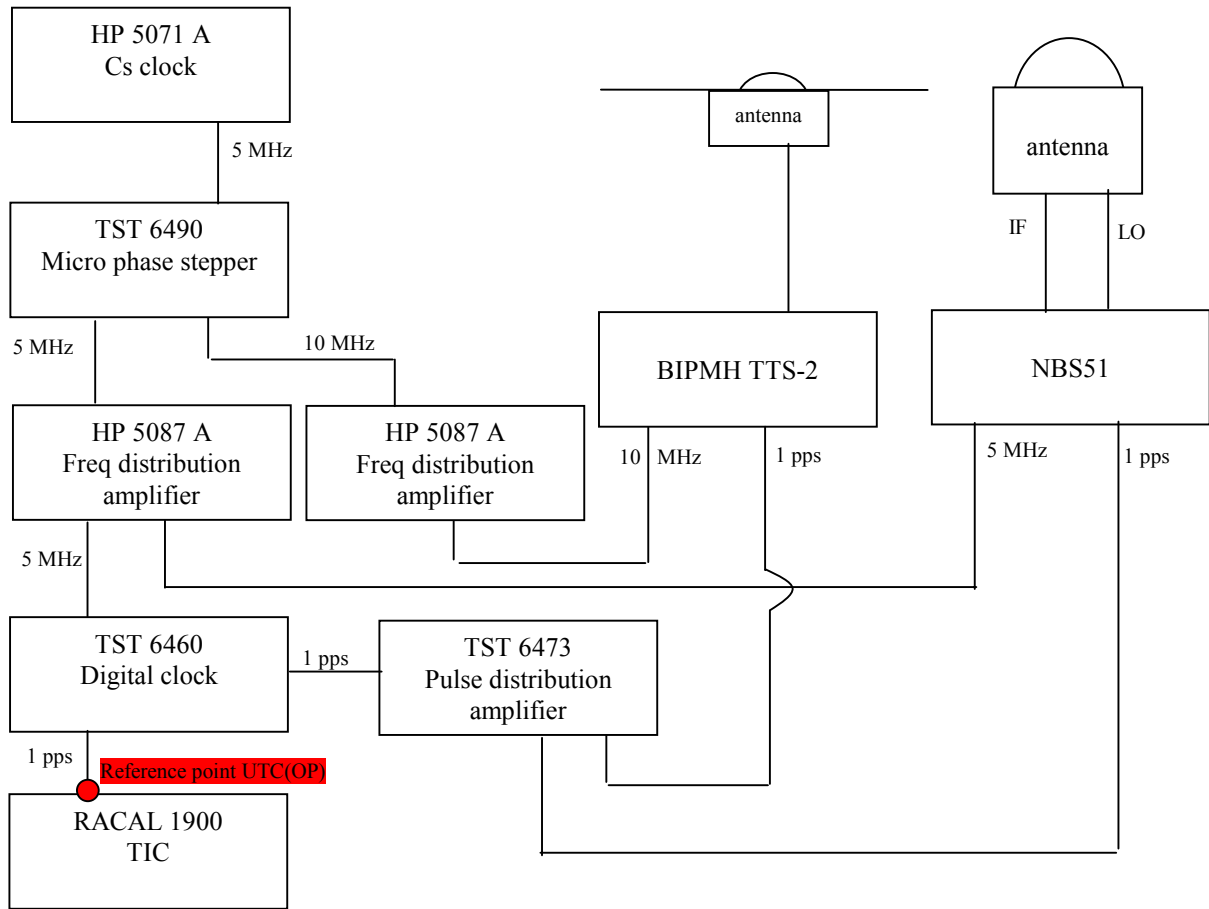

Description of the local method of cable delay measurement:

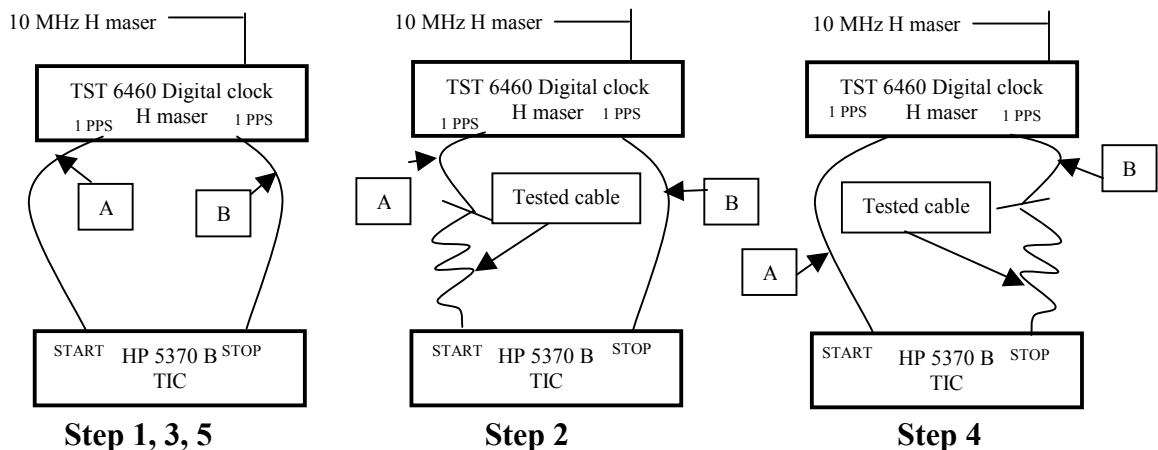

The method used to calibrate the cables is a double weight method in five steps as shown above.

At each step (i) the TIC gives the result (R_i) of 100 measurements.

The test cable delay is then obtained by the following formula:

$$\text{Delay} = \frac{R_2 - \left(\frac{R_1 + R_3}{2}\right) + \left(\frac{R_3 + R_5}{2}\right) - R_4}{2} + \text{corrections}$$

The corrections are the estimated delay introduced by adaptators : - 0,1 ns / adaptator

ANNEX 2

BIPM GPS calibration information sheet

Laboratory:	NPL	
Date and hour of the beginning of measurements:	12.00 MJD 52432	
Date and hour of the end of measurements:	MJD 52442	
Receiver setup information		
	Local:	Portable: BIPM H
• Maker:	Trimble Frequency Solutions	BIPM
• Type:	TTS Receiver	TTS-2
• Serial number:	TFS101	FR72753545
• Receiver internal delay (GPS) :	-31.8 ns	-19,36 ns
• Receiver internal delay (GLO) :	—	
• Antenna cable identification:		C101
Corresponding cable delay :	71.9 ns	184,3 ns ± 0,4 ns
• UTC cable identification:		
Corresponding cable delay :	8425.6 ns	8435.82 ns
Delay to local UTC :	8425.6 ns	8435.82 ns
• Receiver trigger level:		0.5 V
• Coordinates reference frame:		ITRF
Latitude or X m	3985504.03 m	3985505.42 m
Longitude or Y m	-23637.85 m	-23636.42 m
Height or Z m	4962,939.11 m	4962939.80 m
Antenna information		
	Local:	Portable:
• Maker:		Matsushita elec. works
• Type:		GPS
• Serial number:		0709 AU 53022
If the antenna is temperature stabilised	No	
• Set temperature value :		
Local antenna cable information		
• Maker:		
• Type:		
• Is it a phase stabilised cable:	No	
• Length of cable outside the building :		
General information		
• Rise time of the local UTC pulse:		
• Is the laboratory air conditioned:	Yes	
• Set temperature value and uncertainty :		
• Set humidity value and uncertainty :		
Cable delay control		
Cable identification	delay measured by BIPM	Delay measured by local method
BIPM C101	184,34 ns ± 0,4 ns	

Plot of the experiment set-up:

Link to the local UTC of both receivers and Antenna positions

$$(UTC^{(NPL)} \text{ POINT B}) = 8435.82 \text{ ns. (VISITING RECEIVER)}$$

$$(UTC^{(NPL)} \text{ POINT A}) = 8425.60 \text{ ns. (NPL REF RECEIVER)}$$

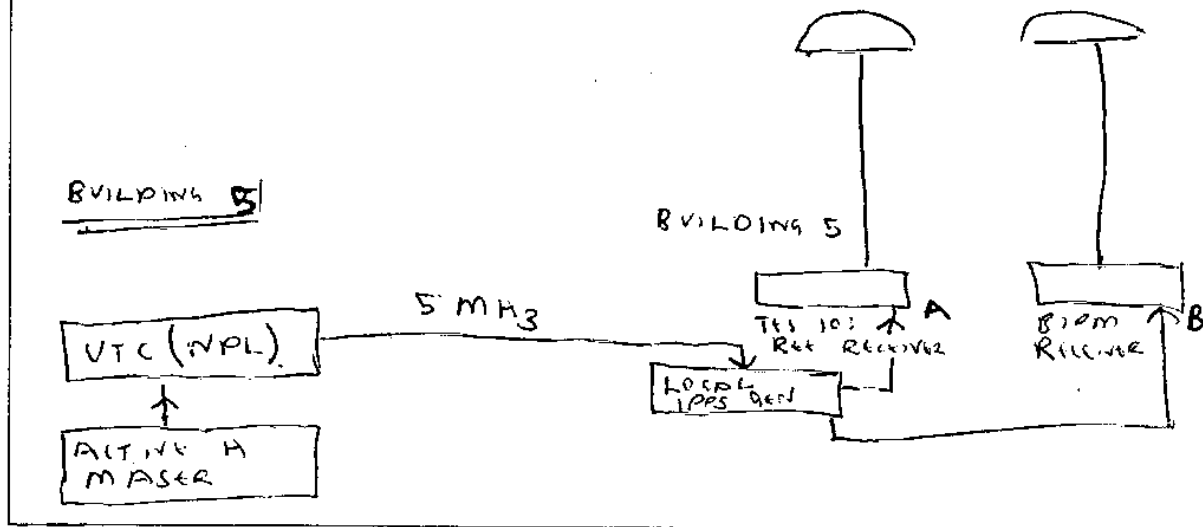

Description of the local method of cable delay measurement:

USE OF SR620 COUNTER TIMER.

BIPM GPS calibration information sheet

Laboratory:	VSL	
Date and hour of the beginning of measurements:	mjd 52445 13:22:00 UTC	
Date and hour of the end of measurements:	mjd 52450 05:34:00 UTC	
Receiver setup information		
	Local: 3SN	Portable: BIPM H
• Maker:	3 S Navigation	BIPM
• Type:	R-100/40T	TTS-2
• Serial number:	RF #0018	FR72753545
• Receiver internal delay (GPS) :	254 ns	-19,36 ns
• Receiver internal delay (GLO) :	27 ns	-
• Antenna cable identification:	GLO #1	C11
Corresponding cable delay :	621 ns	501,53 ns
• UTC cable identification:	-	-
Corresponding cable delay :	-	-
Delay to local UTC :	24.3 ns	19,41 ns
• Receiver trigger level:	0.5 V	0.5 V
• Coordinates reference frame:	ITRF	ITRF
Latitude or X m	+3923530.80 m	+3923531.14 m
Longitude or Y m	+300595.90 m	+300596.8 m
Height or Z m	+5002840.97 m	+5002841.74 m
Antenna information		
	Local:	Portable:
• Maker:	3S Navigation	Matsushita elec. works
• Type:	TSA 100	GPS
• Serial number:		0709 AU 53022
If the antenna is temperature stabilised		
• Set temperature value :	37°C	
Local antenna cable information		
• Maker:		
• Type:		RG 214 u
• Is it a phase stabilised cable:		no
• Length of cable outside the building :		5 m
General information		
• Rise time of the local UTC pulse:		5 ns
• Is the laboratory air conditioned:		yes
• Set temperature value and uncertainty :		23°C ±0.5°C
• Set humidity value and uncertainty :		45% ±5% RH
Cable delay control		
Cable identification	delay measured by BIPM	Delay measured by local method
BIPM C101	184,34 ns ± 0,4 ns	183.1 ns

Plot of the experiment set-up:

Link to the local UTC of both receivers and Antenna positions

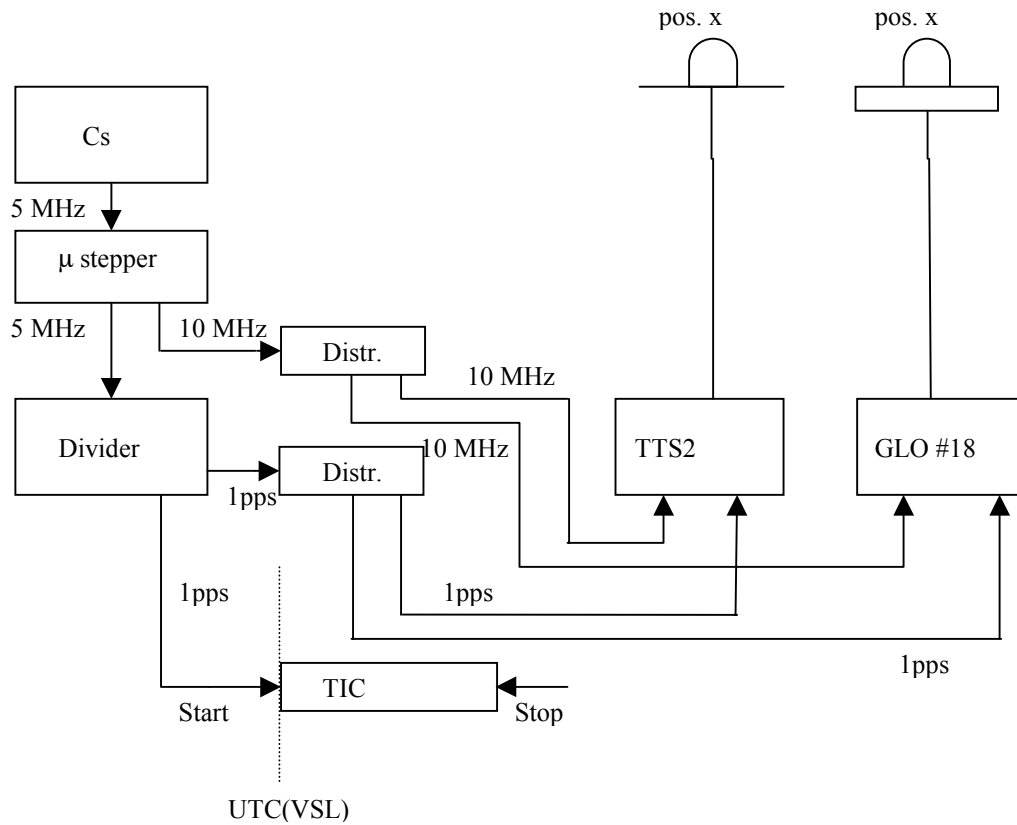

Description of the local method of cable delay measurement:

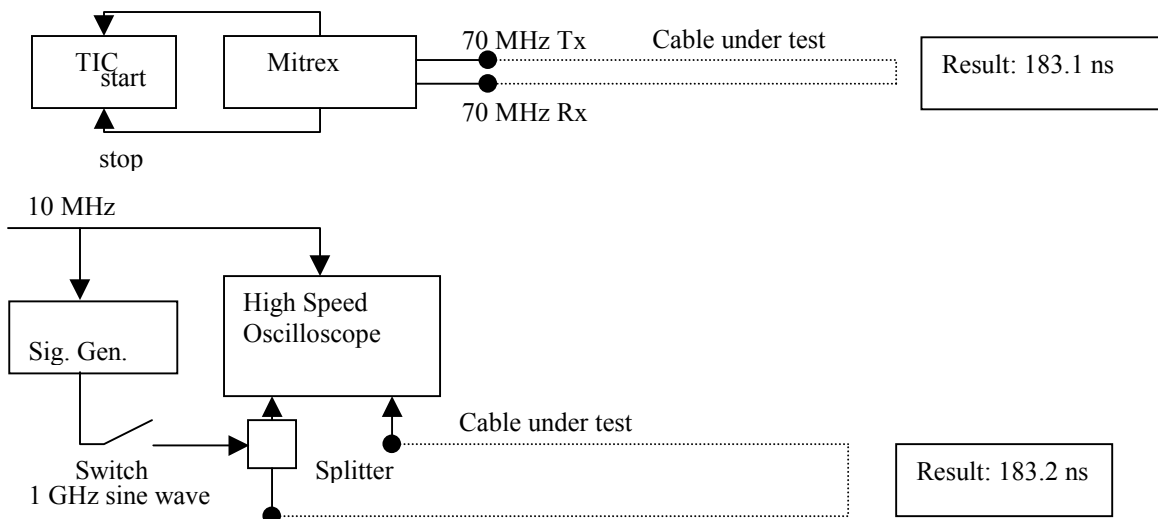

BIPM GPS calibration information sheet

Laboratory:	BNM – SYRTE, Observatoire de Paris	
Date and hour of the beginning of measurements:	8 July 2002 (52463) 10h02	
Date and hour of the end of measurements:	15 July 2002 (52470) 11h58	
Receiver setup information		
	Local: NBS 51	Portable: BIPM H
• Maker:	Allen Osborne Associates	BIPM
• Type:	TTR-5	TTS-2
• Serial number:	051	FR72753545
• Receiver internal delay :	54 ns	-19,36 ns
• Antenna cable identification:	505 IF	C101
Corresponding cable delay :	168 ns \pm 0,3 ns	184,3 ns \pm 0,4 ns
• UTC cable identification:	503	497
Corresponding cable delay :	/	/
Delay to local UTC :	304 ns	306 ns
• Receiver trigger level:	0.5 V	0.5 V
• Coordinates reference frame:	ITRF	ITRF
Latitude:	4 202 780,30 m	4 202 781,970 m
Longitude:	171 370,03 m	171 364,125 m
Height:	4 778 660,12 m	4 778 658,526 m
Antenna information		
	Local:	Portable:
• Maker:	A.O.A.	Matsushita elec. works
• Type:	/	GPS
• Serial number:	/	0709 AU 53022
If the antenna is temperature stabilised		
• Set temperature value :	/	
Local antenna cable information		
• Maker:	/	
• Type:	RG-58	
• Is it a phase stabilised cable:	No	
• Length of cable outside the building :	Approximately 6 meters	
General information		
• Rise time of the local UTC pulse:	4 ns	
• Is the laboratory air conditioned:	Yes	
• Set temperature value and uncertainty :	(21,5 \pm 2) °C	
• Set humidity value and uncertainty :	/	
Cable delay control		
Cable identification	delay measured by BIPM	Delay measured by local method
BIPM C101	184,3 ns \pm 0,4 ns	184,6 ns \pm 0,3 ns

Plot of the experiment set-up:

Link to the local UTC of both receivers and Antenna positions

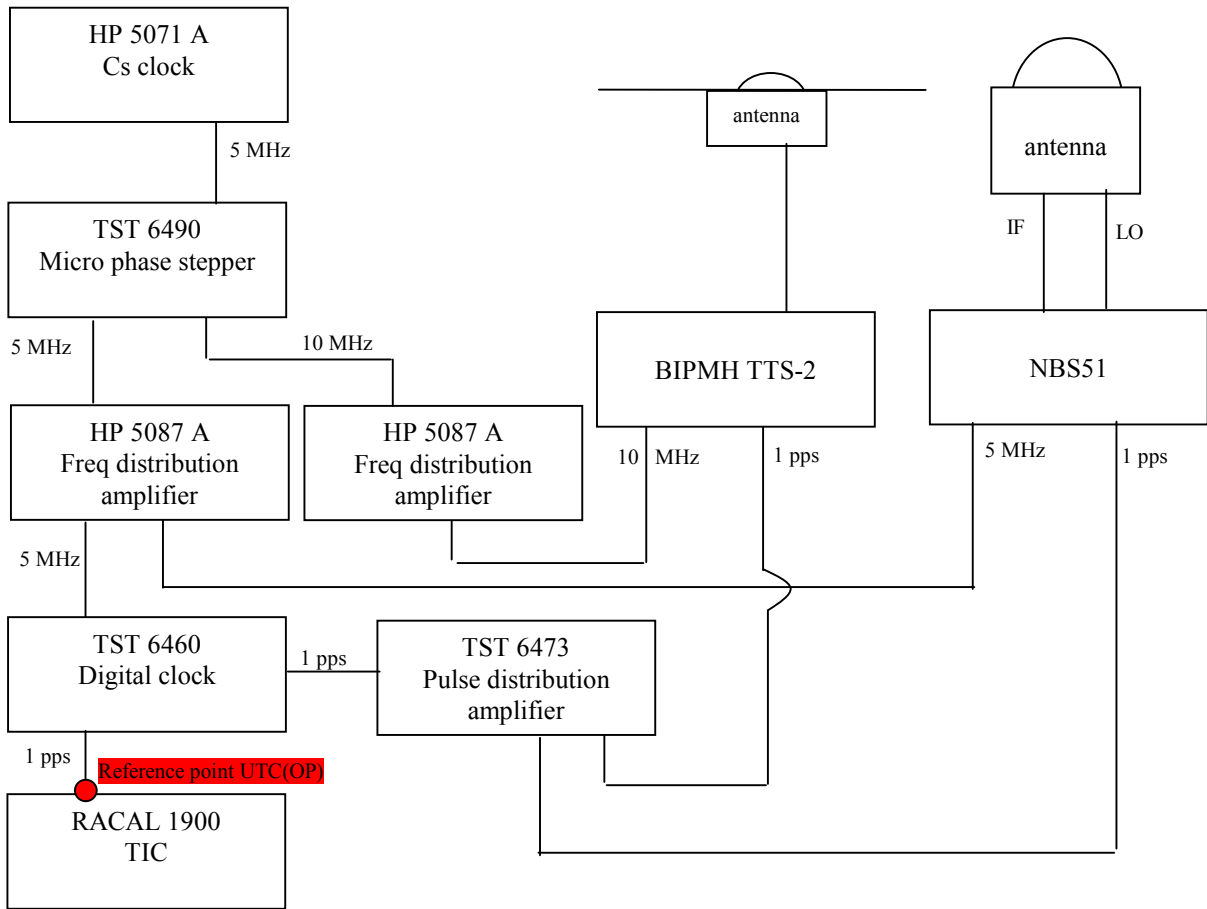

Description of the local method of cable delay measurement:

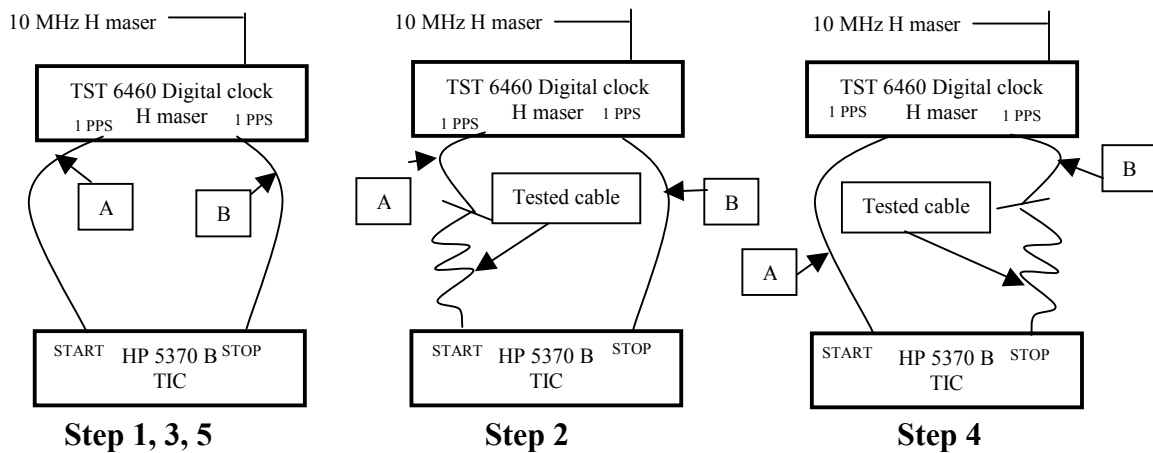

The method used to calibrate the cables is a double weight method in five steps as shown above.

At each step (i) the TIC gives the result (R_i) of 100 measurements.

The test cable delay is then obtained by the following formula:

$$\text{Delay} = \frac{R_2 - \left(\frac{R_1 + R_3}{2}\right) + \left(\frac{R_3 + R_5}{2}\right) - R_4}{2} + \text{corrections}$$

The corrections are the estimated delay introduced by adaptators : - 0,1 ns / adaptator

Appendix II

Measurement of portable cables at the visited laboratories

Laboratory	BIPM C101 cable delay /ns	Measurement method
BIPM	184.34 \pm 0.4	Double-weight pulse method
OP (before trip)	184.6 \pm 0.3	Dual-weighting method
NPL		
VSL	183.1 183.2	Mitrex Modem 1GHz sine + oscilloscope
OCA		
OP (after trip)	184.6 \pm 0.3	Dual-weighting method

Note. The number following the symbol \pm is the numerical value of the standard uncertainty (1σ) and not a confidence interval.

Appendix III**Daily results of the comparisons**

LAB	MJD	Mean offset /ns	Standard deviation of individual common-view observations/ns	Standard deviation of the mean /ns	Number of individual common views
OP	52416	0.42	2.84	0.65	19
	52417	1.58	3.38	0.5	45
	52418	1.96	2.51	0.39	42
	52419	1.59	2.57	0.38	46
	52420	1.42	2.36	0.35	45
	52421	2.79	2.16	0.54	16
NPL	52432	-2.49	2.86	0.2	209
	52433	-2.18	2.85	0.12	554
	52434	-2.82	2.68	0.12	540
	52435	-3.74	1.59	0.71	5
VSL 01	52445	16.07	2.95	0.68	19
	52446	19.85	3.16	0.49	41
	52447	22.1	8.02	1.22	43
	52448	20.66	2.54	0.38	44
	52449	20.55	2.57	0.39	44
	52450	21.82	1.73	0.5	12
VSL R100	52446	12.77	4.37	0.22	404
	52447	12.07	3.36	0.36	87
	52448	12.47	4.12	0.19	488
	52449	13	3.99	0.18	517
	52450	13.22	3.94	0.36	120
OCA	52457	-6.34	1.53	0.22	47
	52458	-6.17	1.59	0.24	45
	52459	-6.2	1.53	0.54	8
OP	52466	6.17	2.51	0.48	27
	52467	5.51	2.7	0.41	44
	52468	5.19	2.64	0.4	44
	52469	6.42	2.47	0.37	45
	52470	6.33	2.05	0.45	21