



**Final report**  
level „B“

Inter - comparison measurements in the field of gas flow and volume  
which are realized at two levels

**The 2nd level (B\*)**

**comparisons of the test rig for verification of industrial gasmeters in range of flow rate  
(100 to 1000) m<sup>3</sup>/h.**

**Meter of comparison – the turbine gasmeter type DAE size G650**

**COOMET Project No. 219/Sk – 00/B**



Coordinator of the comparison:  
Stefan Makovnik  
(Slovak Institute of Metrology)

December 2007

## Acknowledgements

I would like to express my gratitude to everybody, who – to lesser or greater extent – took part in this first comparison measurement in the field of gas flow within the frame of projects realized by COOMET. Special thanks goes to my friends Tomas Valenta from CMI and Bodo Mickan from PTB who kindly granted their assent to use their text and forms of tables in this evaluation of results of measurement.

1.	Introduction .....	5
2.	The comparison meter .....	6
3.	Calibration procedure .....	7
3.1	The test points and the procedure of measurements .....	7
3.2	Calculation of the result of measurement.....	8
4	Test benches of participating laboratories and the received results .....	8
4.1	Slovak Republic, SMU (Premagas) .....	8
4.2	Slovak Republic, AMS - SPP inc., Bratislava.....	10
4.3	Germany .....	12
4.4	Lithuania.....	13
4.5	Republic of Belarus .....	15
4.6	Russia .....	16
4.7	Ukraine .....	18
5	Stability of the comparisons gasmeter and the dependency of laboratories .....	20
5.1	Stability of the meter .....	20
5.2	Dependency of participating laboratories .....	21
6	Determination of the reference value and its uncertainty for each points of flow rate and results of measurements in the participating laboratories .....	21
6.1	Description of the method .....	21
6.1.1	Determination of the reference value and its uncertainty .....	22
6.1.2	The determination of the differences „Lab to CRV“ and „Lab to Lab“ as well as their uncertainties and Degrees of Equivalence <i>En</i> .....	23
6.2	The results of the comparisons measurement .....	26
6.2.1	Flow rate 1000 m <sup>3</sup> /h .....	26
6.2.2	Flow rate 900 m <sup>3</sup> /h .....	27
6.2.3	Flow rate 800 m <sup>3</sup> /h .....	28
6.2.4	Flow rate 700 m <sup>3</sup> /h .....	29
6.2.5	Flow rate 600 m <sup>3</sup> /h .....	30
6.2.6	Flow rate 500 m <sup>3</sup> /h .....	31
6.2.7	Flow rate 400 m <sup>3</sup> /h .....	32
6.2.8	Flow rate 300 m <sup>3</sup> /h .....	33
6.2.9	Flow rate 200 m <sup>3</sup> /h .....	34
6.2.10	Flow rate 100 m <sup>3</sup> /h .....	35
6.3	Comparisons analysis – independent laboratories .....	37
6.3.1	Germany - PTB .....	37
6.3.2	Belarus - BelGIM .....	38

6.3.3	Russia - VNIIR.....	39
6.3.4	Ukraine – GP IFSM.....	40
6.4	Comparisons analysis – dependent laboratories.....	41
6.4.1	Slovakia – SMU (Premagas).....	41
6.4.2	Slovakia – AMS, SPP inc.....	42
6.4.3	Lithuania – LEI .....	43
7	Degree of equivalence evaluation between participating laboratories.....	44
8	Summary and conclusion .....	46

## 1. Introduction

COOMET project No. 219/Sk-00 began in April 2006. The comparisons were realized at two levels. Within the first level (A\*), the comparisons of the test rigs were realized for verification of the diaphragm domestic gas meters in the flow range (from 0,12 to 10) m<sup>3</sup>/h. The comparison measurement means was the set of five diaphragm gas meters of type MKM, size G6. Information on this part of project can be found in a document „Final report – level „A“, COOMET project No 219/Sk-00/A".

The second level (B\*) assured a comparison measurement of testing devices for industry gas meters of flow range (from 100 to 1000) m<sup>3</sup>/h. Comparison meter was an axial turbine gas meter of DAE type, G650 size serial number 0004455/2005.

Seven laboratories participated at this level of project, including laboratory of Belarus with a limited flow rate range (from 100 to 400) m<sup>3</sup>/h. Three laboratories (PTB Braunschweig, Germany, SMU Bratislava, Slovakia and LEI Kaunas, Lithuania) of seven participating laboratories at this level are participants of the projects of comparisons, which are organized within the regional metrological organization EUROMET, out of that laboratory PTB Braunschweig, Germany is also participant in a CIPM key comparison.

During the measurements, every laboratory-participant used its procedure of calibration. The comparison was realized according to the recommendations of COOMET “Recommendations on comparisons of the standards of the national metrological institutes of COOMET” and BIPM directive on realization of key comparisons.

In table 1 is presented a time schedule and an information about participating laboratories in this part of project.

**Table 1 – Time schedule and participants**

Country	Laboratory	Adress of the place of comparison	The declared level of comparison	The date of the measurement	The responsible.
Slovakia	SMU Slovak Institute of Metrology	PREMAGAS s.r.o. A. Schweitzer Sq., 194 91601 Stara Tura  AMS SPP, a.s. Mlynské nivy 44/b 825 11 Bratislava	B* flow range (from 100 to 1000) m <sup>3</sup> /h	2.5. up to 18.5. 2006	Stefan Makovnik
Germany	PTB Physikalisch- Technische Bundesanstalt	PTB Bundesallee 100 38116 Braunschweig	B* flow range (from 100 to 1000) m <sup>3</sup> /h	23.5. up to 29.5. 2006	Bodo Mikan
Lithuania	Lithuanian Energy Institute Research and Testing Laboratory	LEI Breslauyos St., 3 LT- 44403 Kaunas-35	B* flow range (from 100 to 1000) m <sup>3</sup> /h	1.6. up to 15.6. 2006	Yuri Tonkonogy
Belarus	BelGIM	BelGIM Starovilensky Road, 93 220053 Minsk	B* flow range (from 100 to 400) m <sup>3</sup> /h	17.6. up to 28.7. 2006	Nikolai Martynov, Tamara Dikun
Russia	FGUP VNIIR	FGUP VNIIR Vtoraya Aziyskaya 7a, 420029 Kazan	B* flow range (from 100 to 1000) m <sup>3</sup> /h	31.7. up to 10.9. 2006	Sergey Rainchik

Country	Laboratory	Adress of the place of comparison	The declared level of comparison	The date of the measurement	The responsible.
Ukraine	National Research & Metrological Laboratory	GP IFSM Vovchynetska St., 127 Ivano-Frankovsk	B* flow range (from 100 to 1000) m <sup>3</sup> /h	15.9. up to 18.10. 2006	Nikolai Kuz
Slovakia	SMU Slovak Institute of Metrology	PREMAGAS s.r.o. A. Schweitzer Sq., 194 91601 Stara Tura	B* flow range (from 100 to 1000) m <sup>3</sup> /h	11.1.2007 and 6.3.2007	Stefan Makovnik

## 2. The comparison meter

The axial turbine gas meter (*Fig. 1*) was used for the comparison in this level (B\*). The description of this meter is mentioned down.



Type: DAE

Size: G650

Serial number: 0004455/2005

$Q_{max}$  : 1000 m<sup>3</sup>/h

$Q_{min}$  : 100 m<sup>3</sup>/h

Inside diameter: DN 150

$P_{max}$  : 16 bar

The high frequency pulse emitter A1S was used.

Pulse number: 4719,43 imp/m<sup>3</sup>

The emitter A1S was made according to DIN EN S50227 (NAMUR).

Maximum pressure loss in  $Q_{max}$  with air ( $\rho=1,2$  kg/m<sup>3</sup>) : 1400 Pa

Weight: 45 kg

*Figure 1 Axial turbine gas meter*

The dimensions of the meter are mentioned in *table 2* and in the *figure 2*.

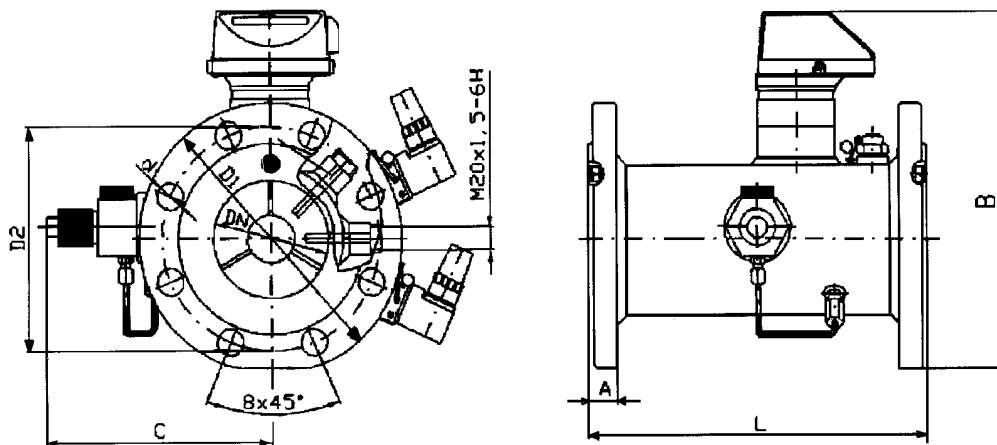
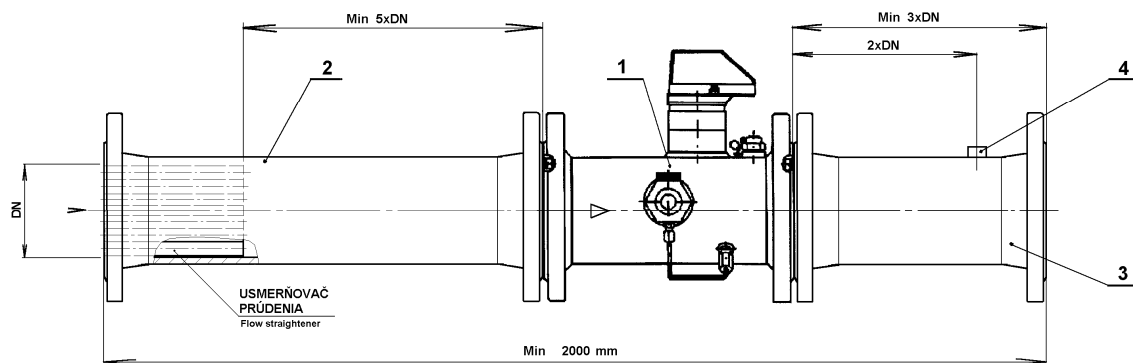

*Figure 2 The dimensions of the meter type DAE*

**Table 2**

Size of gasmeter	Dimensions [mm]							
	DN	L	D1	D2	d	A	B	C
G650	150	450	280	240	23	22	340	195

It was necessary to use the upstream straightening pipe that was long at least 5x DN and the downstream straightening pipe that was long at least 3x DN for the tests. Part of the measurement section is in the *figure 3*.



*Figure 3 Configuration of measuring line with turbine gasmeter type DAE*

The reference pressure from the turbine gas meter was measured from the output “Pin<sub>r</sub>”. The reference temperature from the turbine gas meter was measured in the distance  $(2 \div 3) \times DN$  downstream of the turbine gas meter or in thermometer case of the gasmeter body.

### 3. Calibration procedure

The pulse emitter AIS with the pulse number 4719,43 pulses/m<sup>3</sup> was used for the tests. The calibration should had been performed in the laboratory where the temperature was from 19,56°C up to 22,55°C. No oil lubrication was used.

#### 3.1 The test points and the procedure of measurements

In comparisons measurement for level (B\*), the test was made at the following ten points of flow:

100 m<sup>3</sup>/h, 200 m<sup>3</sup>/h, 300 m<sup>3</sup>/h, 400 m<sup>3</sup>/h, 500 m<sup>3</sup>/h, 600 m<sup>3</sup>/h, 700 m<sup>3</sup>/h, 800 m<sup>3</sup>/h, 900 m<sup>3</sup>/h a 1000 m<sup>3</sup>/h.

The test was repeated at least 3 times in direction from  $Q_{max}$  up to  $Q_{min}$  in each flow rate and then the means of values in the *table 3* mentioned down were calculated. The flow rate had to be in the interval  $\pm 3\%$  of the required value.

**Table 3**

Flow rate in the meter	Absolute pressure in the meter	Temperature in the meter	Pressure loss of the meter	Error of the meter $e_r$	Uncertainty of the error $U (k=2)$
[ m <sup>3</sup> /h ]	[Pa]	[°C]	[Pa]	[%]	[%]
1000					
900					
800					
700					
600					
500					
400					
300					
200					
100					

### 3.2 Calculation of the result of measurement

The result of measurements is determination of the measurement error “ $e$ ”, which is expressed by the difference of the data of the volume of the measured measurement means “ $V_M$ ” and the real value of the flown volume of the measurement means “ $V_E$ ”. The relative error of the measurement, which is expressed in per cents, is the part of the measurement error “ $e$ ” and the real value of the flown volume of the measurement means “ $V_E$ ” multiplied by 100. Such, we have the equation:

$$e_r = \frac{V_M - V_E}{V_E} * 100 \quad [\%] \quad (1)$$

## 4 Test benches of participating laboratories and the received results

### 4.1 Slovak Republic, SMU (Premagas)

The place of measurement: Authorized metrological centre - Premagas, Ltd. Stará Turá.

Date of measurement: 4.5.2006.

Tests were performed at the standard equipment of TRZ, ZP 7630 type with the production number 279/1985. A producer of the equipment is: J.B.Rombach, Karlsruhe and Brehm & Jung electronic, Darmstadt, Germany. The test fluid: air under atmospheric conditions. The test equipment works in a flow range (0,25 - 4000) m<sup>3</sup>/h. The following standard gas meters have taken part in the measurement:

- Rotary gas meter – a gas meter with rotating chambers, of CVM system, with size G 100, produced by: Rockwell, Du Bois, USA, measuring range (16 - 160) m<sup>3</sup>/h, production number 5170521, date of production 1984.  
Traceability: In 2005 an indirect comparison of a gas meter was realised, (by rotary gas meter G100, produced by Elster AG Mainz – Kastel, Germany) with critical nozzles, produced by Elster AG Mainz – Kastel, Germany. The expanded uncertainty

of a measuring is  $U=0,20\%$  ( $k=2$ ). Traceability of the equipment is to the Primary standard for Gas Flow SMU.

- Turbine gas meter of the TRZ G650 DN150 type, produced by: Elster, Germany, measuring range (100 - 1000) m<sup>3</sup>/h, production number 83026952, date of production 1998.

Traceability: In 2005 a direct comparison of the standard gas meter with a standard turbine gas meter type TRZ size G650 production number 83036233/2004 produced by Elster GmbH, in 2004 a traceability of a Standard for Gas Flow PTB was realised. The expanded uncertainty of a measuring is  $U=0,20\%$  ( $k=2$ ) from a measured value of flow.

- Turbine gas meter of the TZ 300 size G 2500, produced by: J. B. Rombach, Germany, measuring range (400 - 4000) m<sup>3</sup>/h, production number 1700035.

Traceability: In 2005 was realised a direct comparison of the standard gas meter with a standard turbine gas meters which were installed in standard equipment CMI, Pardubice. A traceability of standard turbine gas meters of a National standard CMI type EZKUM and Standards PTB was realised. The expanded uncertainty of a measuring is  $U=0,18\%$  ( $k=2$ ) from a measured value of flow.

The comparison measurement was realised according to the SMU working procedure No. 11/230, Version 1 and according to the working procedure No. GAS MS/05 from 2002 authorised by a metrological centre - Premagas, Ltd. Stará Turá. The SMU title of the working procedure: „Working procedure for calibration, verification and tests for type approvals working on a principle of volume measurement“. The title of the Premagas working procedure: „Procedure for verification of turbine gas meters G100 - G 2500“.

The test equipment type TRZ, ZP 7630 during the measurement of comparison is on the following *figure 4*.



*Figure 4 The Premagas test bench TRZ, ZP 7630*

### Results of Slovakia – SMU (Premagas)

Flow rate in the meter	Absolute pressure in the meter	Temperature in the meter	Pressure loss of the meter	Error of the meter $e_r$	Uncertainty of the error $U (k=2)$
[ m <sup>3</sup> /h ]	[Pa]	[°C]	[Pa]	[%]	[%]
1000	97880	22,47	803	-0,16	0,25
900	98240	22,53	635	-0,09	0,25
800	98450	22,39	503	-0,10	0,25
700	98700	22,36	390	-0,08	0,25
600	98920	22,44	295	-0,06	0,25
500	99090	22,47	210	-0,24	0,25
400	99250	22,46	140	-0,39	0,25
300	99390	22,55	80	-0,50	0,25
200	99460	22,47	40	-0,41	0,25
100	99490	22,42	10	-0,20	0,25

The reported expanded uncertainty of measurement is stated as the standard uncertainty of measurement multiplied by the coverage factor  $k = 2$ , which for a normal distribution corresponds to a coverage probability of approximately 95%. The standard uncertainty of measurement has been determined in accordance with EAL Publication EAL-R2 and GUM (Guide to the Expression of Uncertainty in measurement. BIPM/IEC/ISO/OIML, 1993, 1995)

#### 4.2 Slovak Republic, AMS - SPP inc., Bratislava

The place of measurement: Authorized metrological laboratory - SPP inc.,  
Mlynské nivy 44/b, 825 11 Bratislava 26, Slovak republic.

Date of measurement: 10.5.2006.

Tests were performed at the standard equipment of „Raspex“. The test equipment works in a flow range (0,51 - 1000) m<sup>3</sup>/h. Expanded uncertainty of test equipment:  $U=0,28\%$  ( $k=2$ ).

The following standard gas meters have taken part in the measurement:

- Radial turbine gasmeter of the TRZ2 type, size G100, flow range (8 - 160) m<sup>3</sup>/h, produced by: GWF, Switzerland. Traceability: In 2002 an indirect comparison of a gas meter a traceability of a Standart for Gas Flow PTB was realised.
- Axial turbine gas meter of the TZ type, size G650 DN150, produced by: Elster, Germany, measuring range (100 - 1000) m<sup>3</sup>/h. Traceability: In 2002 an indirect comparison of a gas meter a traceability of a Standart for Gas Flow PTB was realised

The test equipment type “Raspex” during the measurement of comparison is on the following *Figure 5*.



Figure 5. The SPP test bench  
„Raspex“

Figure 6 The installation of gasmeter  
on the test bench



### Results of Slovakia – AMS SPP

Flow rate in the meter	Absolute pressure in the meter	Temperature in the meter	Pressure loss of the meter	Error of the meter $e_r$	Uncertainty of the error $U (k=2)$
[ m <sup>3</sup> /h ]	[Pa]	[°C]	[Pa]	[%]	[%]
999,64		20,7	623	-0,31	0,32
900,28		20,7	512	-0,22	0,32
798,42		20,6	418	-0,12	0,32
699,78		20,6	335	-0,13	0,32
600,26		20,5	258	-0,10	0,32
501,69		20,6	188	-0,25	0,32
400,40		20,6	101	-0,46	0,32
300,47		20,7	83	-0,68	0,32
200,54		20,7	24	-0,49	0,32
100,44		20,8	18	-0,16	0,32

The reported expanded uncertainty of measurement is stated as the standard uncertainty of measurement multiplied by the coverage factor  $k = 2$ , which for a normal distribution corresponds to a coverage probability of approximately 95%.

### 4.3 Germany

Place of calibration: Physikalisch-Technische Bundesanstalt (PTB)  
Bundesallee 100, D-38116 Braunschweig, Germany

Date of calibration: 23. May 2006

The nozzle test rig (*Fig. 7*) for large gas meters (2 – 5,600) m<sup>3</sup>/h was used for the calibration of the turbine meter G650.

The computer-controlled nozzle test rig consists of an echelon of 16 Venturi nozzles connected in parallel and operated at sound velocity. This mode of operation guarantees a very high stability of the flow rate selected, with short-term reproducibilities of 0,002%. The uncertainty of measurement amounts to  $U < 0,08 \%$  ( $k = 2$ ).

The sonic nozzle test bench is a secondary standard with traceability to the bell prover (1 - 60 m<sup>3</sup>/h). A bell prover which allows volume flow rates of air at atmospheric pressure to be realized with a measurement uncertainty of  $U < 0,06 \%$  ( $k = 2$ ) serves as the primary standard in Germany.



Figure 7 The nozzle test rig of PTB

## Results of Germany

Flow rate in the meter	Absolute pressure in the meter	Temperature in the meter	Pressure loss of the meter	Error of the meter $e_r$	Uncertainty of the error $U (k=2)$
[ m <sup>3</sup> /h ]	[Pa]	[°C]	[Pa]	[%]	[%]
1029,06	98441	21,38	-470	-0,10	0,08
925,01	98874	21,50	-383	-0,05	0,08
822,57	99181	21,51	-300	-0,01	0,08
718,93	99445	21,55	-227	-0,03	0,08
617,56	99677	21,58	-163	-0,08	0,08
513,82	99871	21,63	-119	-0,21	0,08
411,64	100052	21,64	-65	-0,35	0,08
308,01	100181	21,69	-34	-0,48	0,08
204,59	100270	21,54	-13	-0,40	0,08
103,55	100318	21,47	-3	-0,19	0,08

## 4.4 Lithuania

### Place of the test:

Heat equipment research and testing laboratory of Lithuanian energy institute, 3 Breslaujos str. LT-44403 Kaunas-35, Lithuania

**Date of calibration:** 02.06. 2006 – 09.06.2006

### The test method:

The turbine gas meter G650 was calibrated by the method of comparison the meter's readings with readings of a reference gas meter. The calibration was carried out according to the document KM-2E/3-MP01:2004 «Air (gases) volume and flow rate meters, (1 – 9700) m<sup>3</sup>/h. Methods of calibration».

The turbine gas meter G650 was calibrated at 10 flow rates: (100, 200, 300, 400, 500, 600, 700, 800, 900 and 1000) m<sup>3</sup>/h.

The test at each flow rate was repeated 3 times and then the means were calculated. The deviation of real flow rate values did not exceed  $\pm 3\%$  of the required values.

The tests were carried out without lubrication of the turbine bears.

### The test facility:

The standard facility No. 2E/3 with reference gas meters was used for calibration. The main characteristics of the facility: measurement range is (1 – 9700) m<sup>3</sup>/h, the best measurement capability in the range of flow rate (1 – 1600) m<sup>3</sup>/h is  $\pm 0,25\%$ .

The facility was calibrated 09.12.2004, certificate of calibration No. 118/04-L.

The general view of the facility is presented at *Fig.8*.



Figure 8 . The general view of the standard facility

Round tubes of diameter DN150 were used as straight pipes. The length of upstream straight pipe was  $L_1=1,8$  m (12 DN), downstream –  $L_2=1$  m (6,6 DN). The scheme of the facility is presented at Fig.9.

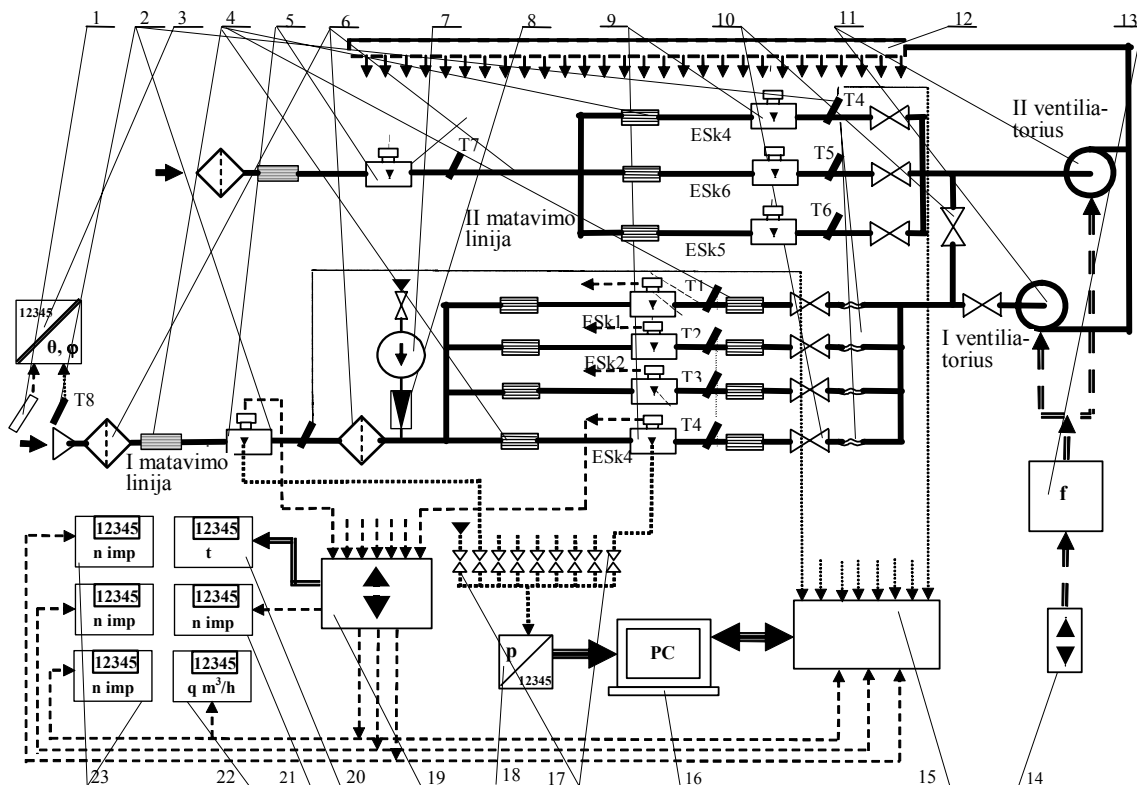

Figure 9. The scheme of the standard facility. 1 – humidity sensor; 2 – thermometers; 3 – temperature and humidity transducer; 4 – flow straightener; 5 – meter under calibration; 6 – air filter; 7 – compressor; 8 – pressure reducer; 9 – reference gas meters; 10 – valves; 11 – fans; 12 – distributing air collector; 13 – frequency converter; 14 – controller of frequency converter; 15 – data acquisition and measurement device; 16 – personal computer ; 17 – pressure tapping connecting valves; 18 – absolute pressure meter; 19 – device of synchronization of time measurement and pulses counting; 20 – timer; 21 –; 22 – electronic flow rate indicator; 23 – reference meters pulses counters.

### Ambient conditions

Atmospheric pressure ( $1005 \pm 8$ ) mbar; temperature ( $20,5 \pm 0,5$ ) °C; relative air humidity ( $36 \pm 2$ ) %.

### Traceability

The reference gas meter of CGT-2 type, G650, DN150, production of the company “COMMON” (Poland), S/N 450116 was used for calibration. The meter was calibrated by PTB (Germany), calibration certificate No.06/028/03 of 19.04.2006.

The temperature, pressure and time measurement devices are traceable to the Lithuanian national standards.

### Results of Lithuania

Flow rate in the meter	Absolute pressure in the meter	Temperature in the meter	Pressure loss of the meter	Error of the meter $e_r$	Uncertainty of the error $U$ ( $k=2$ )
[ m <sup>3</sup> /h ]	[Pa]	[°C]	[Pa]	[%]	[%]
997,8	99,5±5	20,9	Not measured	-0,11	± 0,31 %
890,9		20,7		-0,03	± 0,31 %
797,6		20,5		0,03	± 0,31 %
699,1		20,4		0,03	± 0,31 %
599,0		20,3		-0,04	± 0,31 %
499,4		20,3		-0,17	± 0,31 %
399,7		20,2		-0,36	± 0,31 %
299,5		20,2		-0,49	± 0,31 %
199,5		20,1		-0,33	± 0,31 %
101,4		20,1		0,21	± 0,33 %

## 4.5 Republic of Belarus

### Place of the test:

In comparisons within the framework of the COOMET project 219/8KUOO the bell type unit of the volume and flow of gas RKDU-0,44 №1, that belongs to the RUE "Belgaztehnika" has participated.

**Date of calibration:** 12.07. 2006 – 28.07.2006

**Flow range of measurement:** (from 100 up to 400) m<sup>3</sup>/h

The unit RKDU-0,44 is located in a separate premise, where environment temperature is maintained within the limits ( $20 \pm 5$ ) °C.

The bell type unit of the volume and flow of gas RKDU-0,44 reproduces control air volumes at specified values of its flow by method of displacement at immersion of the bell into make-up liquid (distillated water).

The air volumes, displaced by the bell, are proportional to its run through vertical axis.

The unit RKDU-0,44 №1 allows to reproduce air volumes (from 0,200 to 5,000) m<sup>3</sup> in the flow range (from 4,0 to 1600,0) m<sup>3</sup>/h. The unit RKDU-0,44 №1 has fixed standard air volumes (0,200; 0,400; 0,600; 1,000; 2,000; 5,000) m<sup>3</sup>.

The unit RKDU-0,44 №1 did not participate in comparisons before. The size of volume quantity through the measuring tank of first class, standard weight, is traceable to Russia's standards.

The bell type unit for the gas volume and flow RKDU-0,44 allows to perform measurements in dynamic and static modes.

During measurements in dynamic mode the information on volume, passed through the meter, is taken from the meter pulse output and transmitted through the acquisition and transfer system to the PC, that performs calculation of the pulses quantity and their processing taking into account temperatures and pressures. The processing result is displayed on the monitor screen.

### Results of Belarus

Flow rate in the meter	Absolute pressure in the meter	Temperature in the meter	Pressure loss of the meter	Error of the meter $e_r$	Uncertainty of the error $U$ ( $k=2$ )
m <sup>3</sup> /h	Pa	°C	Pa	%	%
400	103920	20,90	170	+0,06	0,29
300	103974	20,90	100	-0,38	0,41
200	104012	20,86	50	-0,26	0,33
100	104029	20,73	20	-0,35	0,34

### 4.6 Russia

#### Place of the test:

All-Russian Scientific Research Institute of Flowrate Measurement (VNIIR)  
7a, str. 2 Azinskaya, 420029, Kazan, Russia

**Date of calibration:** 17.08. 2006 – 20.08.2006

**Flow range of measurement:** (from 100 up to 1000) m<sup>3</sup>/h

#### Condition of measurement:

Testing medium: air  
 Temperature: (20 ± 2) °C  
 Humidity: (68 up to 72)%  
 Pressure: (748 up to 752) mm Hg; (99,72 up to 100,26) kPa

#### The test facility:

The nozzle test rig standard for industrial gas meters was used for the calibration of the turbine meter G650.

The scheme of the nozzle test rig standard is presented at followed *Figure 10*.



СХЕМА  
калибровки турбинного счётчика газа

Рис. 1

Figure 10. The scheme of the nozzle test rig standard

### Results of Russia

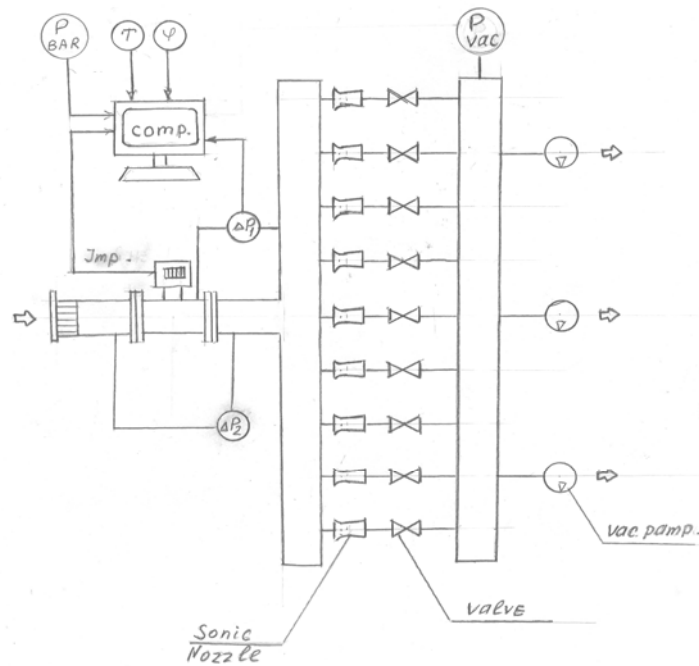
Flow rate in the meter	Absolute pressure in the meter	Temperature in the meter	Pressure loss of the meter	Error of the meter $e_r$	Uncertainty of the error $U$ ( $k=2$ )
$m^3/h$	Pa	$^{\circ}C$	Pa	%	%
1000	$100,6 \cdot 10^3$	21,3	470	+0,38	0,20
900	$100,6 \cdot 10^3$	21,3	410	+0,32	0,20
800	$100,6 \cdot 10^3$	21,3	350	+0,26	0,20
700	$100,6 \cdot 10^3$	21,3	280	+0,22	0,20
600	$100,6 \cdot 10^3$	21,3	220	+0,14	0,20
500	$100,6 \cdot 10^3$	21,3	170	-0,05	0,20
400	$100,6 \cdot 10^3$	21,3	120	-0,26	0,20
300	$100,6 \cdot 10^3$	21,3	80	-0,40	0,20
200	$100,6 \cdot 10^3$	21,3	45	-0,27	0,20
100	$100,6 \cdot 10^3$	21,3	-	-0,08	0,20

#### 4.7 Ukraine

##### Place of the test:

State enterprise „Ivano-Frankivs’kstandartmetrologia“

**Date of calibration:** 15.9.2008 up to 18.10. 2006

**Flow range of measurement:** (from 100 up to 1000) m<sup>3</sup>/h

State enterprise „Ivano-Frankivs’kstandartmetrologia“ use for gas flow meters calibration State primary gas flow standard (bell prover) DETU 03-01-96, flow range (from 4 up to 200) m<sup>3</sup>/h, uncertainty  $U = 0,10\%$  ( $k=2$ ) and initial gas flow standard RKDU-0,44 (bell prover), flow range (from 20 up to 1600) m<sup>3</sup>/h, uncertainty  $U = 0,16\%$  ( $k=2$ ).

The use of the gas flow standards is based on the principle of measuring the time interval required to displacement a known volume of gas at measured temperature and pressure.

Gas volume that passes through the meter under test is determined based on gas law:

$$V_{\Pi} = V_K \cdot \frac{p}{p_0} \cdot \frac{T_0}{T},$$

where  $V_K$  – gas volume reproduced by standard;

$p, p_0$  – inlet meter under test absolute pressure and absolute pressure under bell, respectively;  
 $T, T_0$  – gas temperature on meter under test and under bell, respectively.

Gas volume, measured by meter under test is determined by:

$$V_{N \times} = \frac{N}{K_{NOM}},$$

where  $N$  – number of pulses from meter under test;  $K_{NOM}$  – gas meter  $k$ -factor, pulses/m<sup>3</sup>.

Error of gas meter reading is calculated by:

$$e_r = \frac{V_{Cq} - V_{\Pi}}{V_{\Pi}} \cdot 100$$



*Figure 11:  
Provers appearance State gas flow  
standard DETU 03-01-96 – left,  
gas flow standard RKDU-0,44 – right*

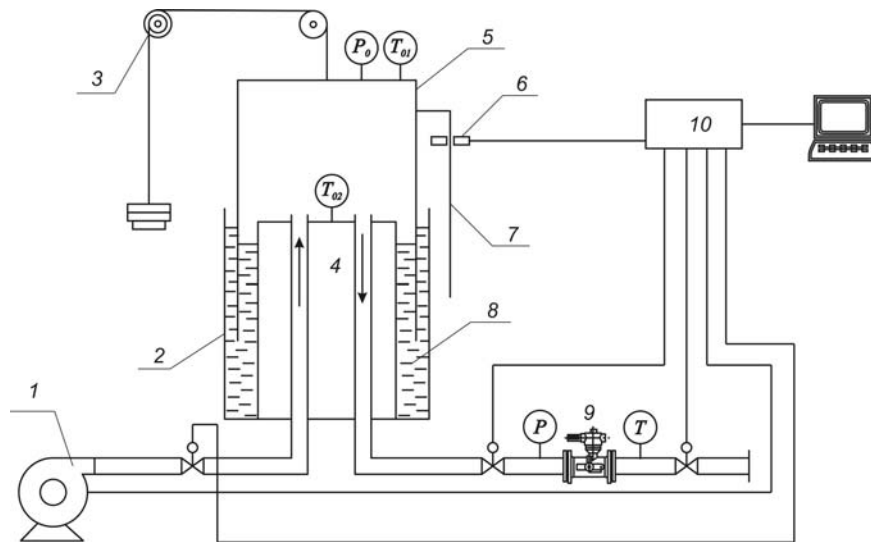

Figure 12 Scheme of gas flow standard (bell prover)

### STANDARD CONFIGURATION

- 1 – blower;
- 2 – tank;
- 3 – buoyancy effect (Archimedean force) compensator (cam);
- 4 – displacer;
- 5 – bell;
- 6 – linear bell displacement transducer;
- 7 – scale;
- 8 – sealing liquid (low vapor mineral oil);
- 9 – meter under test;
- 10 – data gathering and handling system.

### PRINCIPLE OF OPERATION

Standard consists of cylindrical tank (2) and central displacer („dry well“) (4). They together form an annulus that is filled with sealing oil (8). Into this annulus is placed an inverted cylindrical tank, i.e., the bell (5).

Buoyancy effect compensator („Archimedean helix“) (3) is used for compensation buoyancy effect as the bell immersion in sealing liquid changes.

Standard works in the following way. First of all, bell is risen in upper position and make a pause for temperature and pressure stabilization and for sealing oil draining from bell walls.

Set up the desired value of flow rate by means of flow regulator and open outlet valve.

Tests is carried out in dynamic mode (so-called „start in motion“). Linear bell displacement measuring system registers control gas volume passing. At the same time register stop pulse and number of pulses from meter under test.

Then, in accordance with gas law, gas volume, that was passed through the meter under test is calculated and compared with gas volume measuring by meter under test. Then the meter error is calculated.

### Results of Ukraine

Flow rate in the meter	Absolute pressure in the meter	Temperature in the meter	Pressure loss of the meter	Error of the meter $e_r$	Uncertainty of the error $U$ ( $k=2$ )
m <sup>3</sup> /h	Pa	°C	Pa	%	%
992,28	101030	19,56	1004	+0,10	0,22
900,72	101360	19,56	690	+0,02	0,22
800,06	101634	19,58	520	+0,08	0,22
698,36	101882	19,59	380	+0,07	0,22
598,55	102085	19,59	260	+0,01	0,22
501,48	102268	19,62	150	-0,12	0,22
402,26	102422	19,64	100	-0,20	0,22
301,35	102538	19,63	70	-0,30	0,22
199,68	100870	19,71	41	-0,30	0,16
101,54	101200	19,76	5	-0,02	0,16

## 5 Stability of the comparisons gasmeter and the dependency of laboratories

### 5.1 Stability of the meter

During the process of comparative measurements, three measurements were conducted of comparison turbine gasmeter. The first being at the beginning of comparison measurements in May 2006, the second after completing comparison measurements in January 2007. During this measurement, we discovered a shift in the error curve. Therefore a third measurement was conducted in March 2007. The outcomes were similar to those from January. This shift was most probably due to the fact that the meter was new and it needed a longer period of "running-in" before the first use. The outcomes of the measurements are included in the table below.

Table 11 Results of measures in a pilot laboratory

Flow rate in the meter	Error of the meter 4.5.2006 $e_r$	Error of the meter 11.1.2007 $e_r$	Error of the meter 6.3.2007 $e_r$	Maximum difference
[m <sup>3</sup> /h]	[%]	[%]	[%]	[%]
1000	-0,18	0,05	0,02	0,23
900	-0,07	0,09	0,08	0,16
800	-0,07	0,08	0,08	0,15
700	-0,09	0,04	0,06	0,13
600	-0,07	0,05	0,06	0,12
500	-0,24	-0,11	-0,09	0,13
400	-0,42	-0,23	-0,24	0,19
300	-0,50	-0,32	-0,33	0,18
200	-0,42	-0,20	-0,21	0,22
100	-0,18	-0,21	-0,20	-0,03

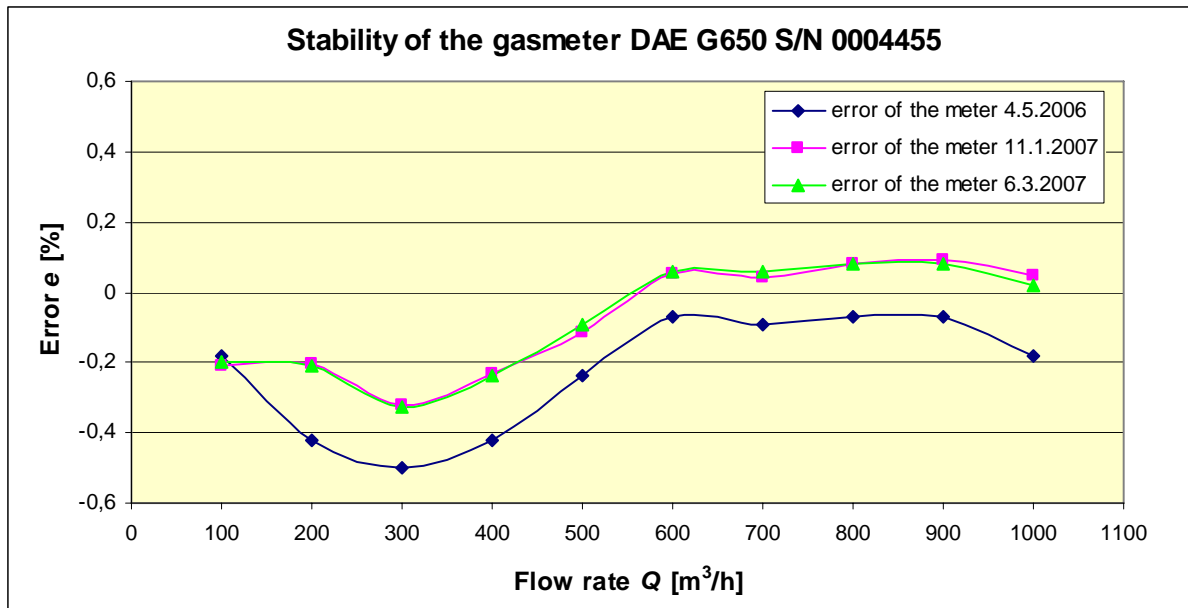

The expanded uncertainty, consequent on the stability of the used comparison meter was determined from maximum value of absolute values of deviations of relative errors  $|\Delta e|$  from first, second and third measurement.  $U_{im} = 0,13 \%$ . This entry is based upon assumption of an equal distribution among maximum and minimum value of a relative error.

## 5.2 Dependency of participating laboratories

On this part of the B-level project, 4 independent laboratories took part. It is Germany (PTB), Belorussia (BelGIM), Russia (VNIIR) and Ukraine (IF DCSMS). These laboratories took part on a determination of reference value of a flow - CRV (comparison reference value) for each test point.

Into the category of dependent laboratories, those from Slovak republic (SMU - Premagas and SPP), Litva (LEI) were included. These laboratories have implemented traceability of standard meters, which are installed in their testing facilities, to Germany (PTB).

## 6 Determination of the reference value and its uncertainty for each points of flow rate and results of measurements in the participating laboratories

### 6.1 Description of the method

The reference value was determined in each flow rate separately. The method of determination of reference value in each flow rate corresponds to the procedure A presented by M. G. Cox<sup>1)</sup>.

<sup>1)</sup> Cox M. G., *Evaluation of key comparison data*, Metrologia, 2002, **39**, 589-595

### 6.1.1 Determination of the reference value and its uncertainty

The reference value  $y$  was calculated as weighted mean error (WME) according to following equation <sup>2)</sup>:

$$y = \frac{\frac{x_1}{u_{x1}^2} + \frac{x_2}{u_{x2}^2} + \dots + \frac{x_n}{u_{xn}^2}}{\frac{1}{u_{x1}^2} + \frac{1}{u_{x2}^2} + \dots + \frac{1}{u_{xn}^2}} \quad (2)$$

where  $x_1, x_2, \dots, x_n$  are errors of the meter in one flow rate in different independent laboratories 1,2, ...n

$u_{x1}, u_{x2}, \dots, u_{xn}$  are standard uncertainties (not expanded) of the error in different independent laboratories 1,2, ...n including the uncertainty caused by stability of the comparisons meter.

The standard uncertainties (not expanded) of the error in different laboratories  $u_{x1}, u_{x2}, \dots, u_{xn}$  include the stability of the comparisons meter were calculated by

$$u_{xi} = \sqrt{\left(\frac{U_{xi\_lab}}{2}\right)^2 + \left(\frac{U_{tm}}{2}\right)^2} \quad (3)$$

where  $U_{xi\_lab}$  is the expanded uncertainty ( $k = 2$ ) determined by laboratory  $i$  and presented in results of laboratory  $i$

$U_{tm}$  is estimated expanded uncertainty caused by the stability (reproducibility) of the turbine gas meter.

The standard uncertainty of the reference value  $u_y$  is given by following equation:

$$\frac{1}{u_y^2} = \frac{1}{u_{x1}^2} + \frac{1}{u_{x2}^2} + \dots + \frac{1}{u_{xn}^2} \quad (4)$$

The expanded uncertainty of the reference value  $U_y$  is given by

$$U_y = 2 \cdot u_y \quad (5)$$

For determination of permissible data dispersion of the independent laboratories was used chi-test. The chi-squared test for consistency check was performed using values of errors of the meter in each flow rate. At first the chi-squared value  $\chi_{obs}^2$  was calculated by

$$\chi_{obs}^2 = \frac{(x_1 - y)^2}{u_{x1}^2} + \frac{(x_2 - y)^2}{u_{x2}^2} + \dots + \frac{(x_n - y)^2}{u_{xn}^2} \quad (6)$$

The degrees of freedom  $\nu$  were assigned

$$\nu = n - 1 \quad (7)$$

where  $n$  is number of evaluated laboratories.

For determination of the reference value the participating laboratories, should perform the following condition:

$$CHINV(0,05;\nu) > \chi_{obs}^2 \quad (8)$$

<sup>2)</sup> B. Mickan, T. Valenta, *Regional Key Comparison EUROMET.M.FF-Kx, Project No. 862 - Final Report*, January 2007

The consistency check was failing if  $CHIINV(0,05;n) < \chi_{obs}^2$ .

If the consistency check failed then the laboratory with the highest value of  $\frac{(x_i - y)^2}{u_{xi}^2}$  was excluded for the next round of evaluation and the new comparison reference value  $y$  (CRV), the new standard uncertainty of the reference value  $u_y$  and the chi-squared value  $\chi_{obs}^2$  were calculated again without the values of excluded laboratory. The consistency check was calculated again, too. This procedure was repeated till the consistency check passed. The function  $CHIINV(0,05;n)$  in MS Excel was used.

If the consistency check did not fail then  $y$  was accepted as the reference value for this comparison measurement  $x_{ref}$  (CRV) and  $U(y)$  was accepted as the expanded uncertainty of the reference value  $U(x_{ref})$ .

### 6.1.2 The determination of the differences „Lab to CRV“ and „Lab to Lab“ as well as their uncertainties and Degrees of Equivalence $En$

When the CRV was determined, the differences between the participating laboratories and the CRV were calculated according to

$$di = x_i - x_{ref} \quad (9)$$

It is necessary to calculate the uncertainty, which relates to difference  $d_i$  (resp.  $d_{ij}$ , see bellow equation (16)) for calculation of the degree of equivalence. At application of the law of the uncertainty expansion the expression of the required parameter follows from the equation:

$$u_{x_1-x_2}^2 = \begin{pmatrix} \frac{\partial(x_1 - x_2)}{\partial x_1} & \frac{\partial(x_1 - x_2)}{\partial x_2} \end{pmatrix} \begin{pmatrix} u_1^2 & \text{cov} \\ \text{cov} & u_2^2 \end{pmatrix} \begin{pmatrix} \frac{\partial(x_1 - x_2)}{\partial x_1} \\ \frac{\partial(x_1 - x_2)}{\partial x_2} \end{pmatrix} = u_1^2 + u_2^2 - 2 \cdot \text{cov} \quad (10)$$

It is clear that the standard uncertainty of measurement, which is got from the interferences at CRV determination between two depended inputs, is created by the sum of squares of the standard uncertainties, which correspond to the individual introduced quantities minus the twice the covariance between the two input values.

Therefore we have to look at the different cases in this comparison:

#### A) Differences to the CRV

##### A1) *Independent laboratories with contribution to the CRV*

The value of covariance is identical to the value of the measurement uncertainty related to CRV for the independent laboratories participants, which took part in CRV determination, and also for the independent laboratories participants. So, value  $u(di)$  is written according to the following equation:

$$u(di) = \sqrt{u_{xi}^2 + u_{xref}^2 - 2 \cdot u_{xref}^2} = \sqrt{u_{xi}^2 - u_{xref}^2} \quad (11)$$

*A2) Independent laboratories without contribution to the CRV*

The independent laboratories participants, which were excluded from CRV determination, do not have interference, so value  $u(di)$  is written according to the following equation:

$$u(di) = \sqrt{u_{xi}^2 + u_{xref}^2} \quad (12)$$

*A3) Laboratories with traceability to a laboratory contributing to the CRV*

In this case we have covariance between the laboratory and the CRV because the laboratory is linked to the CRV via the source of traceability. Although we have no detailed information about it, we can determine a conservative estimation of an upper limit of this covariance. The upper limit is determined for the theoretical case if we have no additional stochastic influence in the traceability of the lab from its source (which is the laboratory contributing to the CRV). Then the results of the laboratory considered here would be strongly correlated with the results of the laboratory contributing to the CRV (correlation coefficient = 1) and there would be the same covariance to the CRV as in case A1. In any case of additional uncertainty caused stochastically the correlation and consequently the covariance is smaller. So, value  $u(di)$  is written according to the following equation:

$$u(di) = \sqrt{u_{xi}^2 + u_{xref}^2 - 2 \cdot u_{xref}^2} = \sqrt{u_{xi}^2 - u_{xref}^2} \quad (13)$$

The expanded uncertainty is calculated according to the equation:

$$U(di) = k \cdot u(di) = 2 \cdot u(di) \quad (14)$$

The basis for estimation of the laboratory successful participation in comparisons is the parameter of the degree of equivalence (**D**egree of **E**quivalence - DoE)  $Ei$ . It is calculated according to the following equation:

$$Ei = \left| \frac{di}{U(di)} \right| \quad (15)$$

At this the used value of uncertainty  $U(di)$  is liable to the above said conditions..

**B) Results of comparison measurement between participating laboratories (Lab to Lab)**

The value of difference between two participating laboratories (Lab to Lab) were calculated according

$$dij = x_i - x_j \quad (16)$$

where  $x_i$  is results laboratory  $i$  and  $x_j$  is results laboratory  $j$ .

*B1) Determinate uncertainty in an independent laboratories*

There is no covariance between the results of two independent laboratory  $i$  and  $j$ . Thereafter the uncertainty were calculated according

$$u(dij) = \sqrt{u_{xi}^2 + u_{xj}^2} \quad (17)$$

where  $u_{xi}$  is standard uncertainty (not expanded) laboratory  $i$  and  $u_{xj}$  is standard uncertainty (not expanded) laboratory  $j$ .

*B2) Dependent laboratories with common source of traceability*

In the case of two laboratories  $i$  and  $j$  with a common source of traceability we will find again a covariance between these laboratories which is caused by the common source. In our case the common source is another laboratory from which the traceabilities of both laboratories are derived. Again, we can determine a conservative upper limit of the covariance for the same reason as in A3 as  $\text{cov} = u_{\text{SourceLab}}^2$ . Thereafter the uncertainty were calculated according

$$u(dij) = \sqrt{u_{xi}^2 + u_{xj}^2 - 2 \cdot u_{\text{SourceLab}}^2} \quad (18)$$

where  $u_{\text{SourceLab}}$  is standard uncertainty (not expanded) master laboratory.

The expanded uncertainty is calculated according to the equation:

$$U(dij) = k \cdot u(dij) = 2 \cdot u(dij) \quad (19)$$

The evaluation of laboratory and their successfully in this part of comparisons measurement gives the parameter DoE -  $Eij$ . It is calculated according to the following equation:

$$Eij = \left| \frac{dij}{U(dij)} \right| \quad (20)$$

The DoE is a measure for the equivalence of the results of any laboratory with the CRV or with any other laboratory, respectively:

- The results of the laboratory are **acceptable (passed)** if  $Ei \leq 1$  or  $Eij \leq 1$
- The results of a laboratory is **not acceptable (failed)** if  $Ei > 1,2$  or  $Eij > 1,2$  (such estimation signals on the serious problems of the laboratory, which must be analysed and removed for proper functioning of the laboratory).
- For values of DoE in the range  $1 < Ei \leq 1,2$  or  $1 < Eij \leq 1,2$ , we define „**warning level**“ were action to check is recommended to the laboratory.

The reason for such „warning level“ is that we have to consider the confidence in the determination of the uncertainties (for the results of labs as well the CRV). Conventionally we work at a 95% confidence level. Therefore in some comparisons a range up to  $E < 1,5$  is used for these „warnings“<sup>3)</sup>. This is a reasonable value where stochastic influences dominate the uncertainty budgets. In the case of comparisons for gas flow rate, the smaller value 1,2 was chosen, which reflects the dominance of non-stochastic parts of uncertainty compared to the stochastic parts. (The reproducibility is usually much better than total uncertainty of a laboratory).<sup>4)</sup>

<sup>3)</sup> C. Ullner a kol., *Special features in proficiency tests of mechanical testing laboratories*, and P. Robouch a kol., *The „Naji Plot“, a simple graphical tool for the evaluation of inter-laboratory comparisons*,

Obidva v : D. Richter, W. Wöger, W. Hässelbarth (ed.) Data analysis of key comparisons, 178. PTB-Seminar/International Workshop, ISBN 3-89701-933-3.

<sup>4)</sup> D. Dopheide, B. Mickan, R. Kramer, H.-J. Hotze, J.-P. Vallet, M.R. Harris, Jiunn-Haur Shaw, Kyung-Am Park, *CIPM Key Comparisons for Compressed Air and Nitrogen, CCM.FF-5.b – Final Report*, 07/09/2006 [http://kcdb.bipm.org/appendixB/appbresults/ccm.ff-k5.b/ccm.ff-k5.b\\_final\\_report.pdf](http://kcdb.bipm.org/appendixB/appbresults/ccm.ff-k5.b/ccm.ff-k5.b_final_report.pdf)

## 6.2 The results of the comparisons measurement

### 6.2.1 Flow rate 1000 m<sup>3</sup>/h

#### The first round of CRV value determination in this point of flow rate

Country (NMI)	Error of the meter $x_i$	Expanded uncertainty $U_{xi} (k = 2)$	$\frac{(x_i - y)^2}{\left(\frac{U_{xi}}{2}\right)^2}$	CRV $x_{ref} = y$	Expanded uncertainty $U_y (k = 2)$
	%	%		%	%
Germany (PTB)	-0,10	0,15	3,95	0,05	0,11
Russia (VNIIR)	0,38	0,24	7,58		
Ukraine (IF)	0,10	0,26	0,14		

$CHIINV =$	5,99
$\chi^2_{obs} =$	11,67

The result of examination of consistency of the obtained parameters does not correspond to the requirements, as  $CHIINV < \chi^2_{obs}$ .

Due to the largest value of parameter “Chi” the result of the Russian laboratory was excluded from the next round of CRV estimation for this point of flow rate.

#### The second and the last round of CRV value determination in this point of flow rate

Country (NMI)	Error of the meter $x_i$	Expanded uncertainty $U_{xi} (k = 2)$	$\frac{(x_i - y)^2}{\left(\frac{U_{xi}}{2}\right)^2}$	CRV $x_{ref} = y$	Expanded uncertainty $U_y (k = 2)$
	%	%		%	%
Germany (PTB)	-0,10	0,15	0,47	-0,05	0,13
Ukraine (IF)	0,10	0,26	1,33		

$CHIINV =$	3,84
$\chi^2_{obs} =$	1,81

The result of examination of consistency of the obtained parameters corresponds to the requirements, as  $CHIINV > \chi^2_{obs}$ .

#### The results of measurement at flow rate value 1000 m<sup>3</sup>/h

Country (NMI)	Error of the meter $x_i$	Expanded uncertainty $U_{xi} (k = 2)$	$d_i$	$U(d_i)$	$E_i$
	%	%	%	%	–
Slovakia (SMU - Premagas)	-0,16	0,28	-0,113	0,249	0,45
Slovakia (AMS SPP)	-0,31	0,35	-0,262	0,320	0,82
Germany (PTB)	-0,10	0,15	-0,053	0,078	0,67
Lithuania (LEI)	-0,11	0,34	-0,063	0,310	0,20
Russia (VNIIR)	0,38	0,24	0,427	0,199	2,14
Ukraine (IF)	0,10	0,26	0,147	0,219	0,67

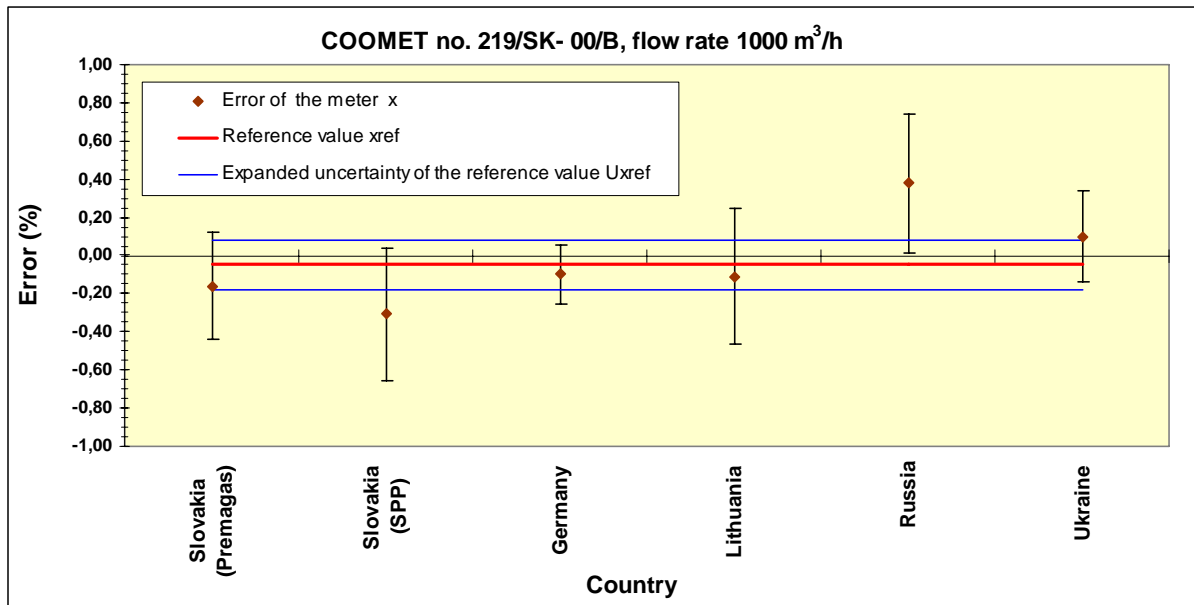

### 6.2.2 Flow rate 900 m<sup>3</sup>/h

#### The first round of CRV value determination in this point of flow rate

Country (NMI)	Error of the meter $x_i$	Expanded uncertainty $U_{xi} (k = 2)$	$\frac{(x_i - y)^2}{\left(\frac{U_{xi}}{2}\right)^2}$	CRV $x_{ref} = y$	Expanded uncertainty $U_v (k = 2)$
	%	%		%	%
Germany (PTB)	-0,05	0,15	1,76	0,05	0,11
Russia (VNIIR)	0,32	0,24	5,19		
Ukraine (IF)	0,02	0,26	0,05		

$CHIINV =$	5,99
$\chi^2_{obs} =$	7,00

The result of examination of consistency of the obtained parameters does not correspond to the requirements, as  $CHIINV < \chi^2_{obs}$ .

Due to the largest value of parameter “Chi” the result of the Russian laboratory was excluded from the next round of CRV estimation for this point of flow rate.

#### The second and the last round of CRV value determination in this point of flow rate

Country (NMI)	Error of the meter $x_i$	Expanded uncertainty $U_{xi} (k = 2)$	$\frac{(x_i - y)^2}{\left(\frac{U_{xi}}{2}\right)^2}$	CRV $x_{ref} = y$	Expanded uncertainty $U_v (k = 2)$
	%	%		%	%
Germany (PTB)	-0,05	0,15	0,06	-0,03	0,13
Ukraine (IF)	0,02	0,26	0,18		

$CHIINV =$	3,84
$\chi^2_{obs} =$	0,24

The result of examination of consistency of the obtained parameters corresponds to the requirements, as  $CHIINV > \chi^2_{obs}$ .

**The results of measurement at flow rate value 900 m<sup>3</sup>/h**

Country (NMI)	Error of the meter $x_i$	Expanded uncertainty $U_{xi} (k = 2)$	$d_i$	$U(d_i)$	$E_i$
	%	%	%	%	–
Slovakia (SMU - Premagas)	-0,09	0,28	-0,059	0,249	0,24
Slovakia (AMS SPP)	-0,22	0,35	-0,182	0,320	0,57
Germany (PTB)	-0,05	0,15	-0,019	0,078	0,25
Lithuania (LEI)	-0,03	0,34	0,004	0,310	0,01
Russia (VNIIR)	0,32	0,24	0,354	0,199	1,78
Ukraine (IF)	0,02	0,26	0,054	0,219	0,25

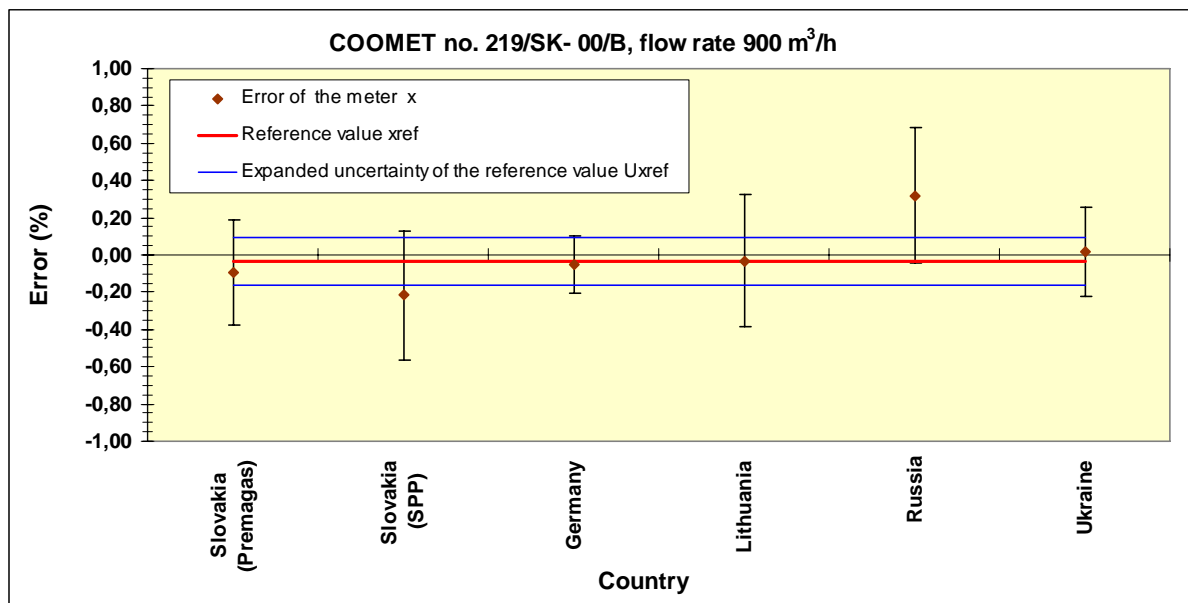

6.2.3 Flow rate 800 m<sup>3</sup>/h

**The first and the last round of CRV value determination in this point of flow rate**

Country (NMI)	Error of the meter $x_i$	Expanded uncertainty $U_{xi} (k = 2)$	$\frac{(x_i - y)^2}{\left(\frac{U_{xi}}{2}\right)^2}$	CRV $x_{ref} = y$	Expanded uncertainty $U_y (k = 2)$
	%	%		%	%
Germany (PTB)	-0,05	0,15	1,16	0,07	0,11
Russia (VNIIR)	0,32	0,24	2,56		
Ukraine (IF)	0,02	0,26	0,01		

$CHIINV =$	5,99
$\chi^2_{obs} =$	3,73

The result of examination of consistency of the obtained parameters corresponds to the requirements, as  $CHIINV > \chi^2_{obs}$ .

**The results of measurement at flow rate value 800 m<sup>3</sup>/h**

Country (NMI)	Error of the meter $x_i$	Expanded uncertainty $U_{xi} (k = 2)$	$d_i$	$U(d_i)$	$E_i$
	%	%	%	%	–
Slovakia (SMU - Premagas)	-0,10	0,28	-0,169	0,257	0,66
Slovakia (AMS SPP)	-0,12	0,35	-0,193	0,326	0,59
Germany (PTB)	-0,01	0,15	-0,082	0,101	0,82
Lithuania (LEI)	0,03	0,34	-0,039	0,316	0,12
Russia (VNIIR)	0,26	0,24	0,191	0,209	0,91
Ukraine (IF)	0,08	0,26	0,011	0,228	0,05

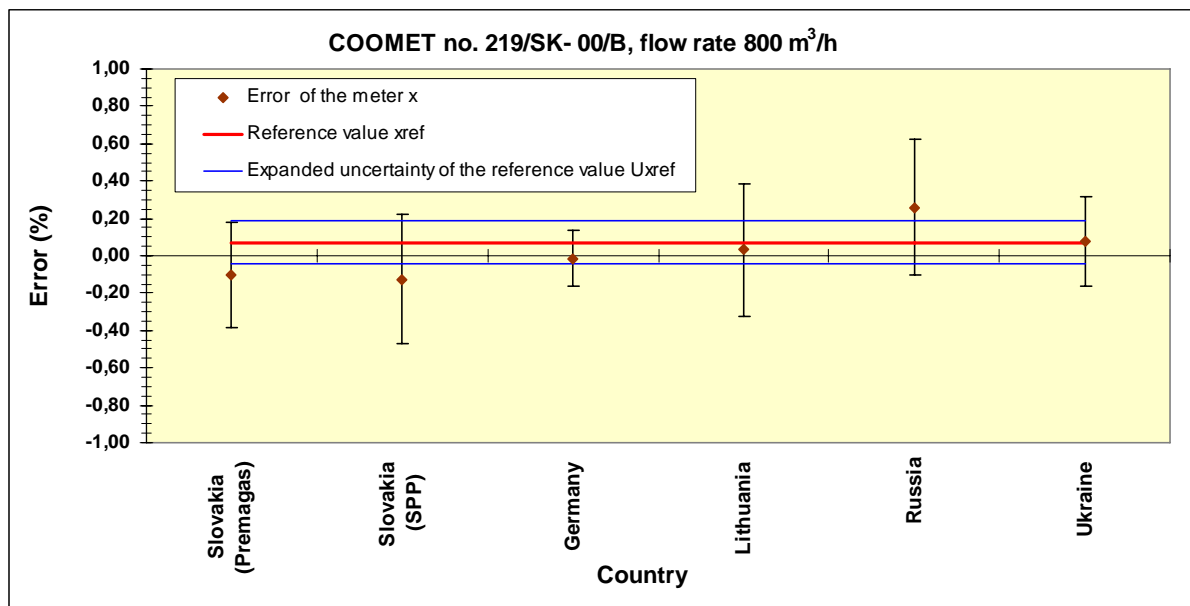

6.2.4 Flow rate 700 m<sup>3</sup>/h

**The first and the last round of CRV value determination in this point of flow rate**

Country (NMI)	Error of the meter $x_i$	Expanded uncertainty $U_{xi} (k = 2)$	$\frac{(x_i - y)^2}{\left(\frac{U_{xi}}{2}\right)^2}$	CRV $x_{ref} = y$	Expanded uncertainty $U_y (k = 2)$
	%	%		%	%
Germany (PTB)	-0,03	0,15	1,08	0,05	0,11
Russia (VNIIR)	0,22	0,24	2,12		
Ukraine (IF)	0,07	0,26	0,03		

$CHIINV =$	5,99
$\chi^2_{obs} =$	3,24

The result of examination of consistency of the obtained parameters corresponds to the requirements, as  $CHIINV > \chi^2_{obs}$ .

**The results of measurement at flow rate value 700 m<sup>3</sup>/h**

Country (NMI)	Error of the meter $x_i$	Expanded uncertainty $U_{xi} (k = 2)$	$d_i$	$U(d_i)$	$E_i$
	%	%	%	%	–
Slovakia (SMU - Premagas)	-0,08	0,28	-0,124	0,257	0,48
Slovakia (AMS SPP)	-0,13	0,35	-0,178	0,326	0,55
Germany (PTB)	-0,03	0,15	-0,079	0,101	0,79
Lithuania (LEI)	0,03	0,34	-0,016	0,316	0,05
Russia (VNIIR)	0,22	0,24	0,174	0,209	0,83
Ukraine (IF)	0,07	0,26	0,024	0,228	0,10

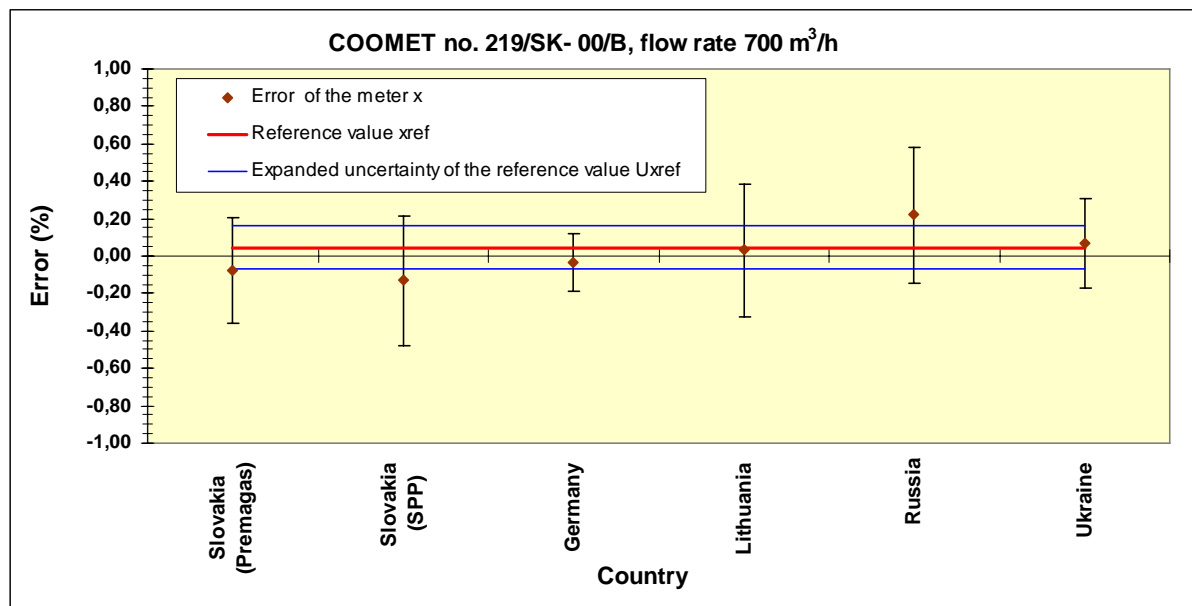

6.2.5 Flow rate 600 m<sup>3</sup>/h

**The first and the last round of CRV value determination in this point of flow rate**

Country (NMI)	Error of the meter $x_i$	Expanded uncertainty $U_{xi} (k = 2)$	$\frac{(x_i - y)^2}{\left(\frac{U_{xi}}{2}\right)^2}$	CRV $x_{ref} = y$	Expanded uncertainty $U_y (k = 2)$
	%	%		%	%
Germany (PTB)	-0,08	0,15	0,85	-0,01	0,11
Russia (VNIIR)	0,14	0,24	1,64		
Ukraine (IF)	0,01	0,26	0,03		

$CHIINV =$	5,99
$\chi^2_{obs} =$	2,52

The result of examination of consistency of the obtained parameters corresponds to the requirements, as  $CHIINV > \chi^2_{obs}$ .

**The results of measurement at flow rate value 600 m<sup>3</sup>/h**

Country (NMI)	Error of the meter $x_i$	Expanded uncertainty $U_{xi} (k = 2)$	$d_i$	$U(d_i)$	$E_i$
	%	%	%	%	–
Slovakia (SMU - Premagas)	-0,06	0,28	-0,050	0,257	0,19
Slovakia (AMS SPP)	-0,10	0,35	-0,087	0,326	0,27
Germany (PTB)	-0,08	0,15	-0,070	0,101	0,70
Lithuania (LEI)	-0,04	0,34	-0,027	0,316	0,09
Russia (VNIIR)	0,14	0,24	0,153	0,209	0,73
Ukraine (IF)	0,01	0,26	0,023	0,228	0,10

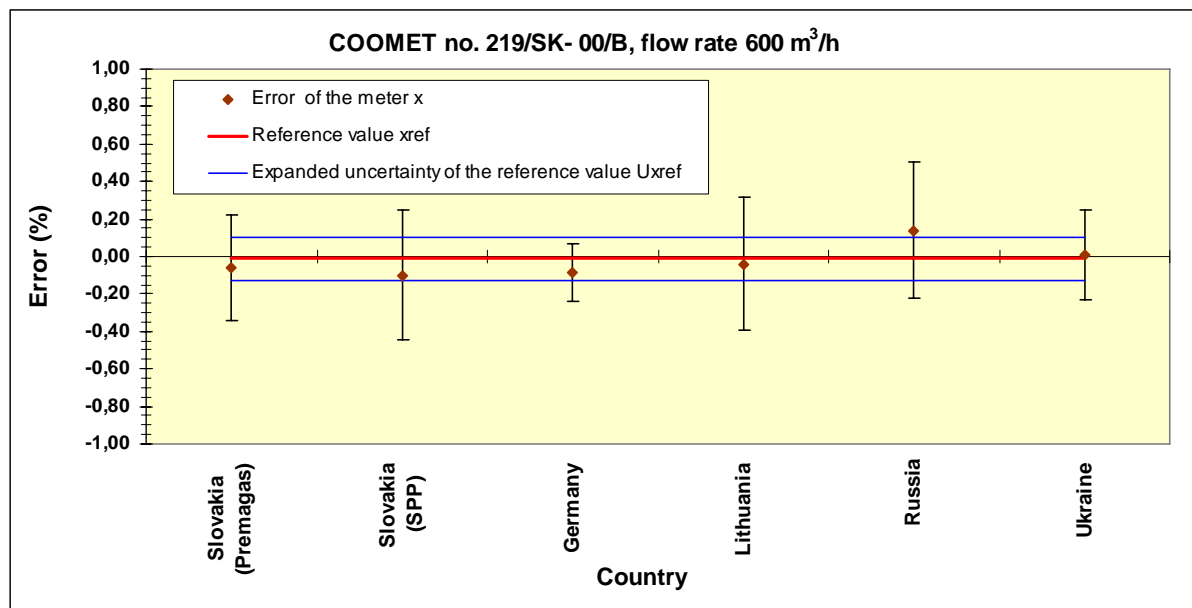

6.2.6 Flow rate 500 m<sup>3</sup>/h

**The first and the last round of CRV value determination in this point of flow rate**

Country (NMI)	Error of the meter $x_i$	Expanded uncertainty $U_{xi} (k = 2)$	$\frac{(x_i - y)^2}{\left(\frac{U_{xi}}{2}\right)^2}$	CRV $x_{ref} = y$	Expanded uncertainty $U_y (k = 2)$
	%	%		%	%
Germany (PTB)	-0,21	0,15	0,50	-0,15	0,11
Russia (VNIIR)	-0,05	0,24	0,75		
Ukraine (IF)	-0,12	0,26	0,07		

$CHIINV =$	5,99
$\chi^2_{obs} =$	1,31

The result of examination of consistency of the obtained parameters corresponds to the requirements, as  $CHIINV > \chi^2_{obs}$ .

**The results of measurement at flow rate value 500 m<sup>3</sup>/h**

Country (NMI)	Error of the meter $x_i$	Expanded uncertainty $U_{xi} (k = 2)$	$d_i$	$U(d_i)$	$E_i$
	%	%	%	%	–
Slovakia (SMU - Premagas)	-0,24	0,28	-0,087	0,257	0,34
Slovakia (AMS SPP)	-0,25	0,35	-0,100	0,326	0,31
Germany (PTB)	-0,21	0,15	-0,054	0,101	0,54
Lithuania (LEI)	-0,17	0,34	-0,017	0,316	0,05
Russia (VNIIR)	-0,05	0,24	0,103	0,209	0,49
Ukraine (IF)	-0,12	0,26	0,033	0,228	0,14

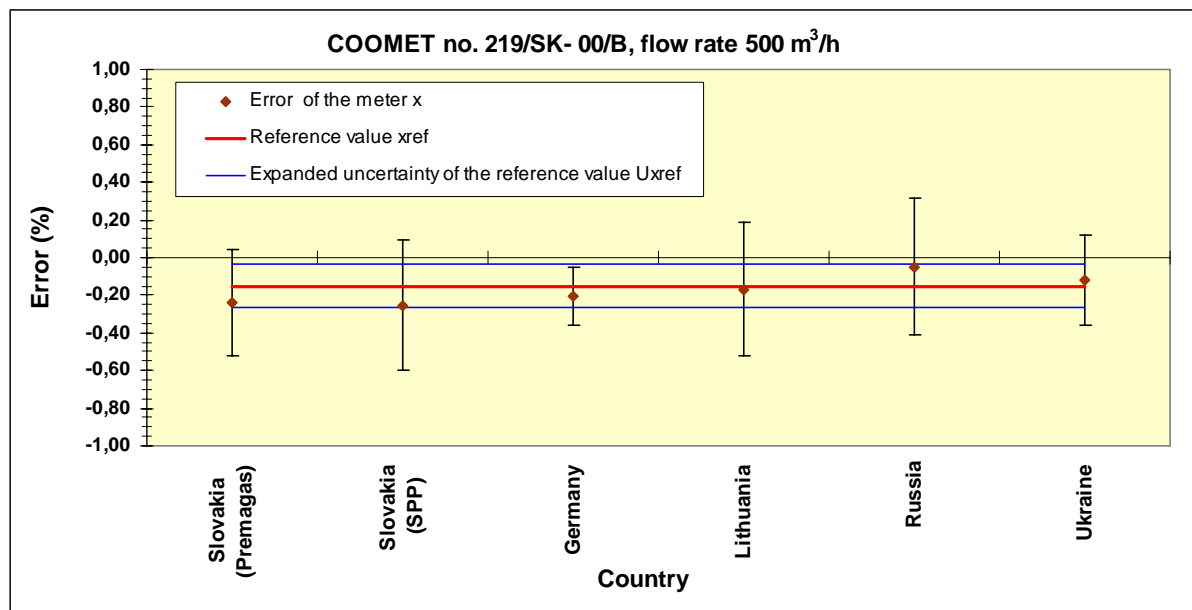

6.2.7 Flow rate 400 m<sup>3</sup>/h

**The first and the last round of CRV value determination in this point of flow rate**

Country (NMI)	Error of the meter $x_i$	Expanded uncertainty $U_{xi} (k = 2)$	$\frac{(x_i - y)^2}{\left(\frac{U_{xi}}{2}\right)^2}$	CRV $x_{ref} = y$	Expanded uncertainty $U_v (k = 2)$
	%	%		%	%
Germany (PTB)	-0,35	0,15	1,52	-0,26	0,11
Belarus (BelGIM)	0,06	0,32	4,03		
Russia (VNIIR)	-0,26	0,24	0,00		
Ukraine (IF)	-0,20	0,26	0,21		

$CHIINV =$	7,81
$\chi^2_{obs} =$	5,76

The result of examination of consistency of the obtained parameters corresponds to the requirements, as  $CHIINV > \chi^2_{obs}$ .

**The results of measurement at flow rate value 400 m<sup>3</sup>/h**

Country (NMI)	Error of the meter $x_i$	Expanded uncertainty $U_{xi} (k = 2)$	$d_i$	$U(d_i)$	$E_i$
	%	%	%	%	–
Slovakia (SMU - Premagas)	-0,39	0,28	-0,131	0,260	0,50
Slovakia (AMS SPP)	-0,46	0,35	-0,198	0,328	0,60
Germany (PTB)	-0,35	0,15	-0,094	0,108	0,87
Lithuania (LEI)	-0,36	0,34	-0,101	0,318	0,32
Belarus (BelGIM)	0,06	0,32	0,319	0,299	1,07
Russia (VNIIR)	-0,26	0,24	-0,001	0,213	0,01
Ukraine (IF)	-0,20	0,26	0,059	0,232	0,25

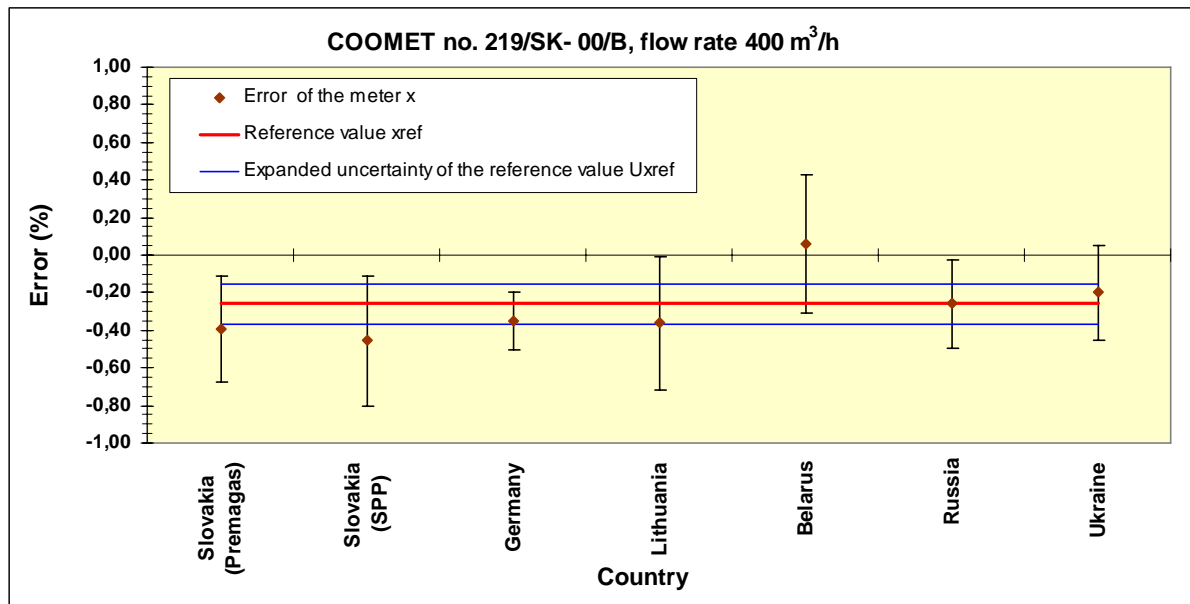

6.2.8 Flow rate 300 m<sup>3</sup>/h

**The first and the last round of CRV value determination in this point of flow rate**

Country (NMI)	Error of the meter $x_i$	Expanded uncertainty $U_{xi} (k = 2)$	$\frac{(x_i - y)^2}{\left(\frac{U_{xi}}{2}\right)^2}$	CRV $x_{ref} = y$	Expanded uncertainty $U_y (k = 2)$
	%	%		%	%
Germany (PTB)	-0,48	0,15	0,60	-0,42	0,11
Belarus (BelGIM)	-0,38	0,43	0,04		
Russia (VNIIR)	-0,40	0,24	0,04		
Ukraine (IF)	-0,30	0,26	0,94		

$CHIINV =$	7,81
$\chi^2_{obs} =$	1,62

The result of examination of consistency of the obtained parameters corresponds to the requirements, as  $CHIINV > \chi^2_{obs}$ .

**The results of measurement at flow rate value 300 m<sup>3</sup>/h**

Country (NMI)	Error of the meter $x_i$	Expanded uncertainty $U_{xi} (k = 2)$	$d_i$	$U(d_i)$	$E_i$
	%	%	%	%	–
Slovakia (SMU - Premagas)	-0,50	0,28	-0,074	0,259	0,29
Slovakia (AMS SPP)	-0,68	0,35	-0,254	0,327	0,78
Germany (PTB)	-0,48	0,15	-0,059	0,105	0,57
Lithuania (LEI)	-0,49	0,34	-0,066	0,317	0,21
Belarus (BelGIM)	-0,38	0,43	0,044	0,416	0,11
Russia (VNIIR)	-0,40	0,24	0,024	0,211	0,11
Ukraine (IF)	-0,30	0,26	0,124	0,230	0,54

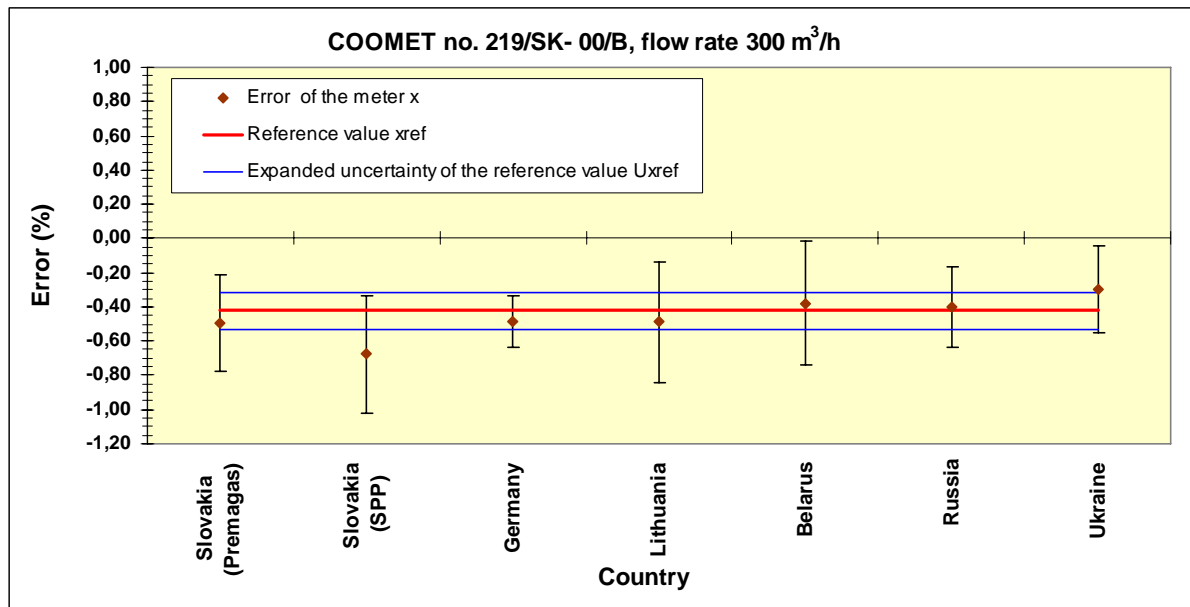

6.2.9 Flow rate 200 m<sup>3</sup>/h

**The first and the last round of CRV value determination in this point of flow rate**

Country (NMI)	Error of the meter $x_i$	Expanded uncertainty $U_{xi} (k = 2)$	$\frac{(x_i - y)^2}{\left(\frac{U_{xi}}{2}\right)^2}$	CRV $x_{ref} = y$	Expanded uncertainty $U_y (k = 2)$
	%	%		%	%
Germany (PTB)	-0,40	0,15	0,56	-0,34	0,11
Belarus (BelGIM)	-0,26	0,35	0,20		
Russia (VNIIR)	-0,27	0,24	0,34		
Ukraine (IF)	-0,30	0,26	0,10		

$CHIINV =$	7,81
$\chi^2_{obs} =$	1,20

The result of examination of consistency of the obtained parameters corresponds to the requirements, as  $CHIINV > \chi^2_{obs}$ .

**The results of measurement at flow rate value 200 m<sup>3</sup>/h**

Country (NMI)	Error of the meter $x_i$	Expanded uncertainty $U_{xi} (k = 2)$	$d_i$	$U(d_i)$	$E_i$
	%	%	%	%	–
Slovakia (SMU - Premagas)	-0,41	0,28	-0,070	0,260	0,27
Slovakia (AMS SPP)	-0,49	0,35	-0,148	0,328	0,45
Germany (PTB)	-0,40	0,15	-0,057	0,107	0,54
Lithuania (LEI)	-0,33	0,34	0,010	0,318	0,03
Belarus (BelGIM)	-0,26	0,35	0,080	0,337	0,24
Russia (VNIIR)	-0,27	0,24	0,070	0,212	0,33
Ukraine (IF)	-0,30	0,26	0,040	0,231	0,17

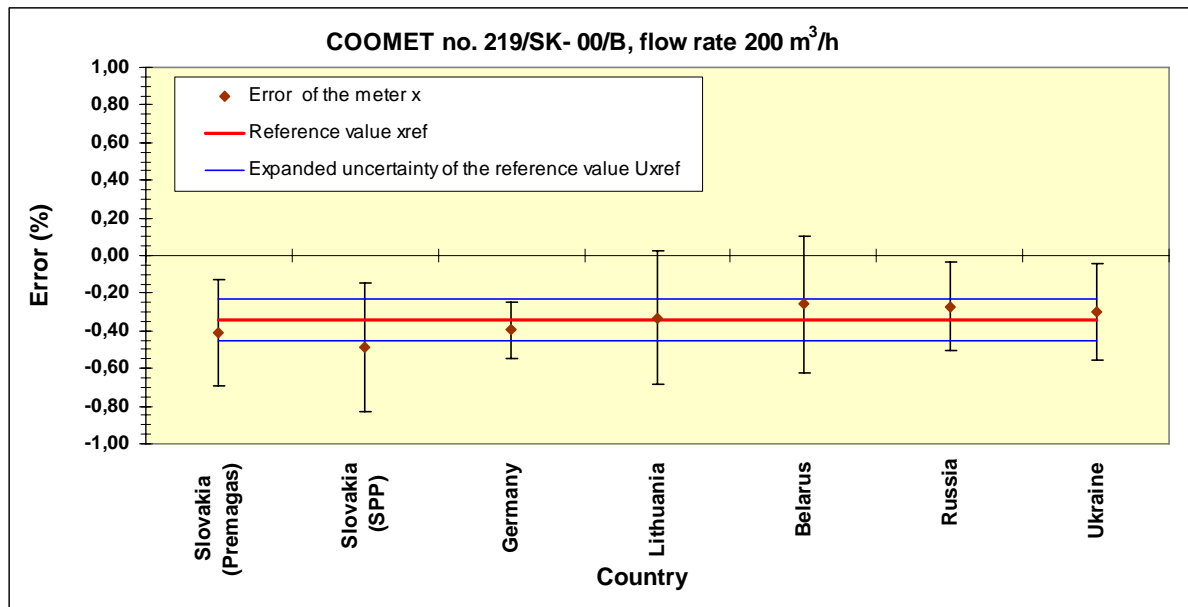

6.2.10 Flow rate 100 m<sup>3</sup>/h

**The first and the last round of CRV value determination in this point of flow rate**

Country (NMI)	Error of the meter $x_i$	Expanded uncertainty $U_{xi} (k = 2)$	$\frac{(x_i - y)^2}{\left(\frac{U_{xi}}{2}\right)^2}$	CRV $x_{ref} = y$	Expanded uncertainty $U_y (k = 2)$
	%	%		%	%
Germany (PTB)	-0,19	0,15	0,27	-0,15	0,11
Belarus (BelGIM)	-0,35	0,36	1,21		
Russia (VNIIR)	-0,08	0,24	0,35		
Ukraine (IF)	-0,02	0,26	1,04		

$CHIINV =$	7,81
$\chi^2_{obs} =$	2,87

The result of examination of consistency of the obtained parameters corresponds to the requirements, as  $CHIINV > \chi^2_{obs}$ .

**The results of measurement at flow rate value 100 m<sup>3</sup>/h**

Country (NMI)	Error of the meter $x_i$	Expanded uncertainty $U_{xi} (k = 2)$	$d_i$	$U(d_i)$	$E_i$
	%	%	%	%	–
Slovakia (SMU - Premagas)	-0,20	0,28	-0,045	0,260	0,17
Slovakia (AMS SPP)	-0,16	0,35	-0,013	0,328	0,04
Germany (PTB)	-0,19	0,15	-0,040	0,106	0,38
Lithuania (LEI)	0,21	0,35	0,360	0,337	1,07
Belarus (BelGIM)	-0,35	0,36	-0,200	0,347	0,58
Russia (VNIIR)	-0,08	0,24	0,070	0,212	0,33
Ukraine (IF)	-0,02	0,26	0,130	0,231	0,56

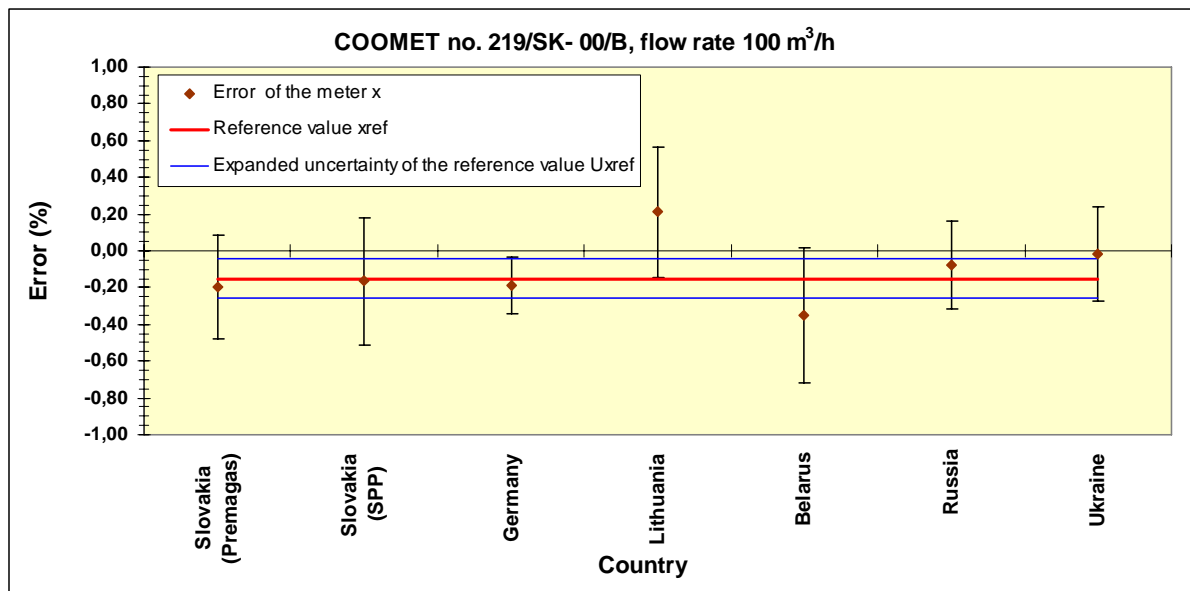

### 6.3 Comparisons analysis – independent laboratories

#### 6.3.1 Germany - PTB

Flow rate	Error of the meter $x_i$	Expanded uncertainty $U_{xi}$ ( $k = 2$ )	CRV $x_{ref} = y$	Expanded uncertainty of the CRV $U_v$ ( $k = 2$ )	Consistency check *)	$d_i$	$E_i$	Result
$m^3/h$	%	%	%	%		–	–	
1000	-0,10	0,15	-0,05	0,13	yes	-0,05	0,67	passed
900	-0,05	0,15	-0,03	0,13	yes	-0,02	0,25	passed
800	-0,01	0,15	0,07	0,11	yes	-0,08	0,82	passed
700	-0,03	0,15	0,05	0,11	yes	-0,08	0,79	passed
600	-0,08	0,15	-0,01	0,11	yes	-0,07	0,70	passed
500	-0,21	0,15	-0,15	0,11	yes	-0,05	0,54	passed
400	-0,35	0,15	-0,26	0,11	yes	-0,09	0,87	passed
300	-0,48	0,15	-0,42	0,11	yes	-0,06	0,57	passed
200	-0,40	0,15	-0,34	0,11	yes	-0,06	0,54	passed
100	-0,19	0,15	-0,15	0,11	yes	-0,04	0,38	passed
<b>Mean</b>						<b>-0,06</b>	<b>0,61</b>	<b>passed</b>

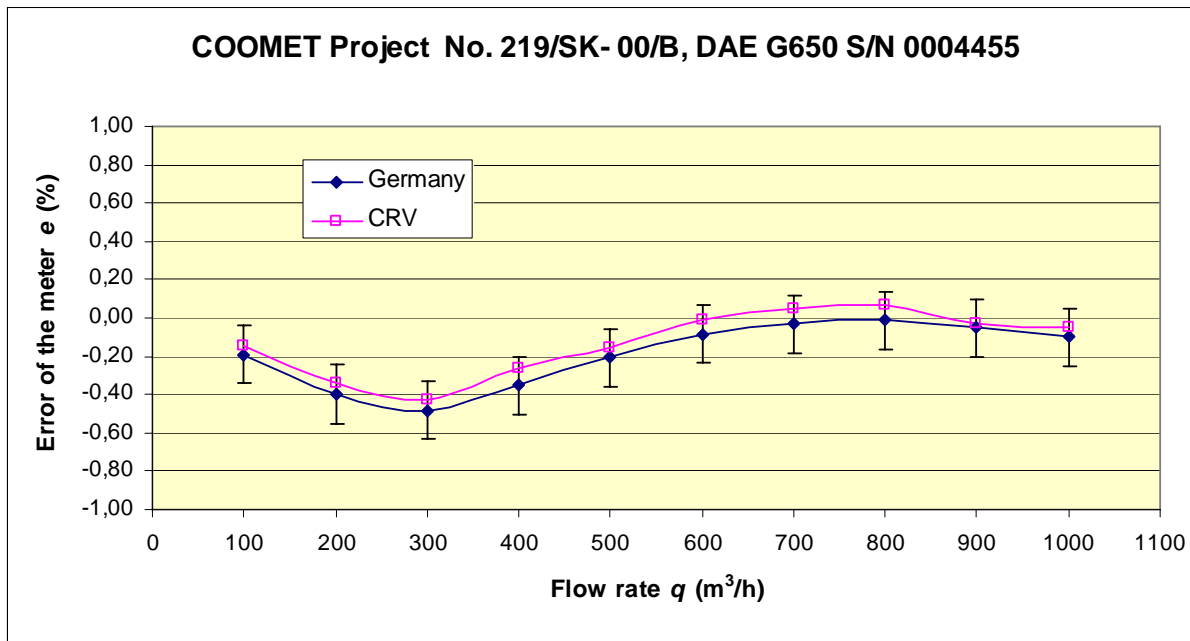

\*) The word **yes** means that the laboratory result took part in the determination of CRV reference value.  
The word **no** means that the laboratory result was excluded from the determination of CRV reference value.

### 6.3.2 Belarus - BelGIM

Flow rate	Error of the meter $x_i$	Expanded uncertainty $U_{xi}$ ( $k = 2$ )	CRV $x_{ref} = y$	Expanded uncertainty of the CRV $U_y$ ( $k = 2$ )	Consistency check *)	$d_i$	$E_i$	Result
$m^3/h$	%	%	%	%		–	–	
400	0,06	0,318	-0,26	0,11	yes	0,32	1,07	warning
300	-0,38	0,430	-0,42	0,11	yes	0,04	0,11	passed
200	-0,26	0,355	-0,34	0,11	yes	0,08	0,24	passed
100	-0,35	0,364	-0,15	0,11	yes	-0,20	0,58	passed
					<b>Mean</b>	<b>0,06</b>	<b>0,50</b>	<b>passed</b>

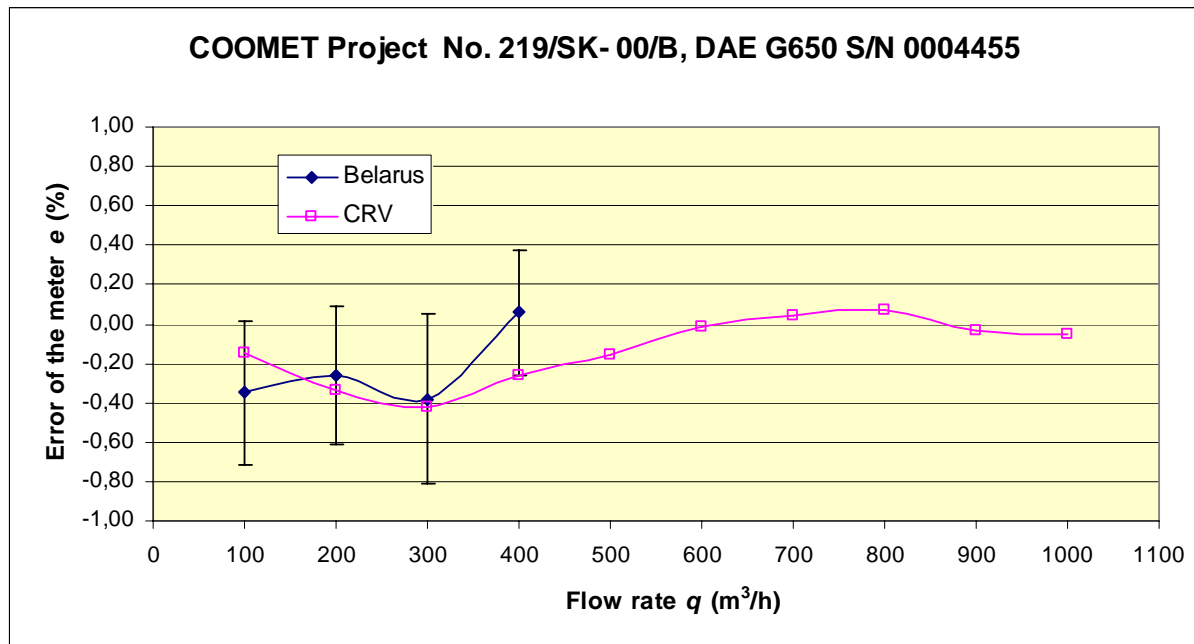

\*) The word **yes** means that the laboratory result took part in the determination of CRV reference value.  
The word **no** means that the laboratory result was excluded from the determination of CRV reference value.

### 6.3.3 Russia - VNIIR

Flow rate	Error of the meter $x_i$	Expanded uncertainty $U_{x_i}$ ( $k=2$ )	CRV $x_{ref}=y$	Expanded uncertainty of the CRV $U_y$ ( $k=2$ )	Consistency check <sup>*)</sup>	$d_i$	$E_i$	Result
m <sup>3</sup> /h	%	%	%	%		–	–	
1000	0,38	0,24	-0,05	0,13	no	0,43	2,14	failed
900	0,32	0,24	-0,03	0,13	no	0,35	1,78	failed
800	0,26	0,24	0,07	0,11	yes	0,19	0,91	passed
700	0,22	0,24	0,05	0,11	yes	0,17	0,83	passed
600	0,14	0,24	-0,01	0,11	yes	0,15	0,73	passed
500	-0,05	0,24	-0,15	0,11	yes	0,10	0,49	passed
400	-0,26	0,24	-0,26	0,11	yes	0,00	0,01	passed
300	-0,40	0,24	-0,42	0,11	yes	0,02	0,11	passed
200	-0,27	0,24	-0,34	0,11	yes	0,07	0,33	passed
100	-0,08	0,24	-0,15	0,11	yes	0,07	0,33	passed
					<b>Mean</b>	<b>0,16</b>	<b>0,77</b>	<b>passed</b>

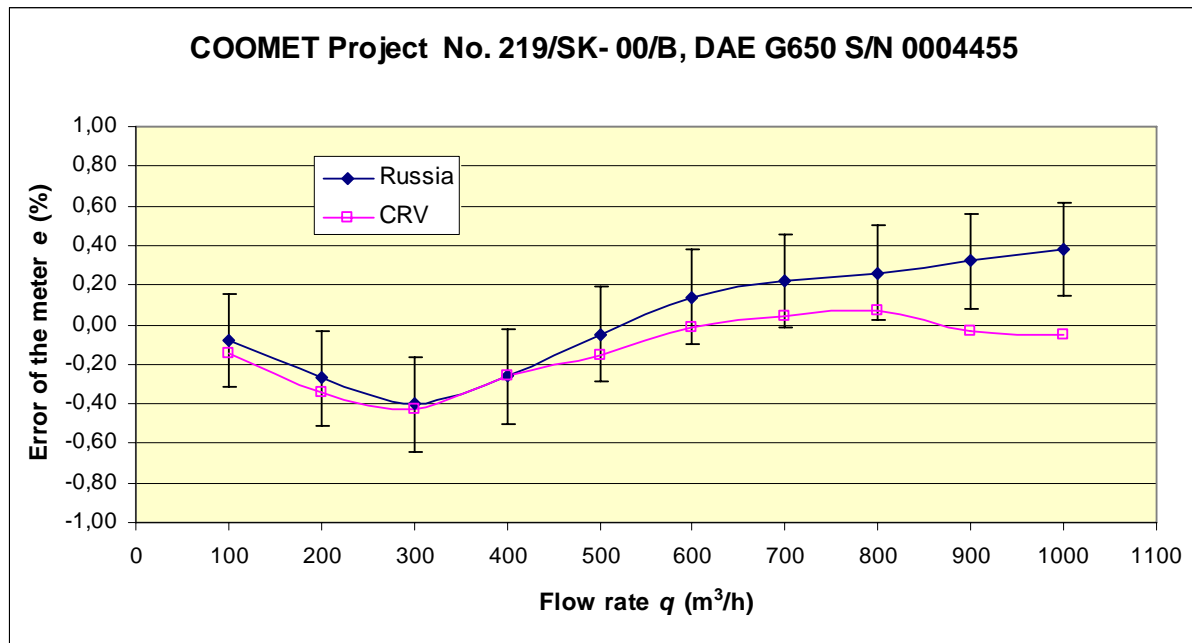

\* ) The word **yes** means that the laboratory result took part in the determination of CRV reference value.  
The word **no** means that the laboratory result was excluded from the determination of CRV reference value.

6.3.4 Ukraine – GP IFSM

Flow rate	Error of the meter $x_i$	Expanded uncertainty $U_{x_i}$ ( $k=2$ )	CRV $x_{ref}=y$	Expanded uncertainty of the CRV $U_y$ ( $k=2$ )	Consistency check *)	$d_i$	$E_i$	Result
m <sup>3</sup> /h	%	%	%	%		–	–	
1000	0,10	0,26	-0,05	0,13	yes	0,15	0,67	passed
900	0,02	0,26	-0,03	0,13	yes	0,05	0,25	passed
800	0,08	0,26	0,07	0,11	yes	0,01	0,05	passed
700	0,07	0,26	0,05	0,11	yes	0,02	0,10	passed
600	0,01	0,26	-0,01	0,11	yes	0,02	0,10	passed
500	-0,12	0,26	-0,15	0,11	yes	0,03	0,14	passed
400	-0,20	0,26	-0,26	0,11	yes	0,06	0,25	passed
300	-0,30	0,26	-0,42	0,11	yes	0,12	0,54	passed
200	-0,30	0,26	-0,34	0,11	yes	0,04	0,17	passed
100	-0,02	0,26	-0,15	0,11	yes	0,13	0,56	passed
<b>Mean</b>						<b>0,06</b>	<b>0,28</b>	<b>passed</b>

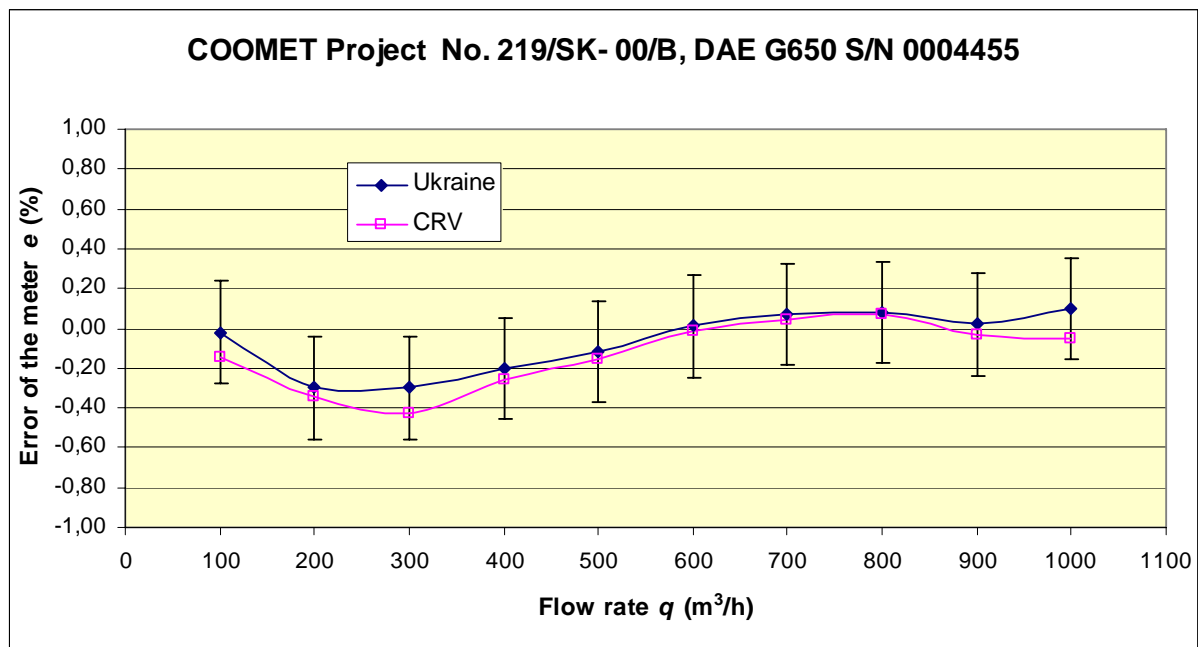

\*) The word **yes** means that the laboratory result took part in the determination of CRV reference value.  
The word **no** means that the laboratory result was excluded from the determination of CRV reference value.

## 6.4 Comparisons analysis – dependent laboratories

### 6.4.1 Slovakia – SMU (Premagas)

Flow rate	Error of the meter $x_i$	Expanded uncertainty $U_{xi}$ ( $k = 2$ )	CRV $x_{ref} = y$	Expanded uncertainty of the CRV $U_y$ ( $k = 2$ )	$d_i$	$E_i$	Result
m <sup>3</sup> /h	%	%	%	%	–	–	
1000	-0,16	0,28	-0,05	0,13	-0,11	0,45	passed
900	-0,09	0,28	-0,03	0,13	-0,06	0,24	passed
800	-0,10	0,28	0,07	0,11	-0,17	0,66	passed
700	-0,08	0,28	0,05	0,11	-0,12	0,48	passed
600	-0,06	0,28	-0,01	0,11	-0,05	0,19	passed
500	-0,24	0,28	-0,15	0,11	-0,09	0,34	passed
400	-0,39	0,28	-0,26	0,11	-0,13	0,50	passed
300	-0,50	0,28	-0,42	0,11	-0,07	0,29	passed
200	-0,41	0,28	-0,34	0,11	-0,07	0,27	passed
100	-0,20	0,28	-0,15	0,11	-0,04	0,17	passed
			<b>Mean</b>		<b>-0,09</b>	<b>0,36</b>	<b>passed</b>

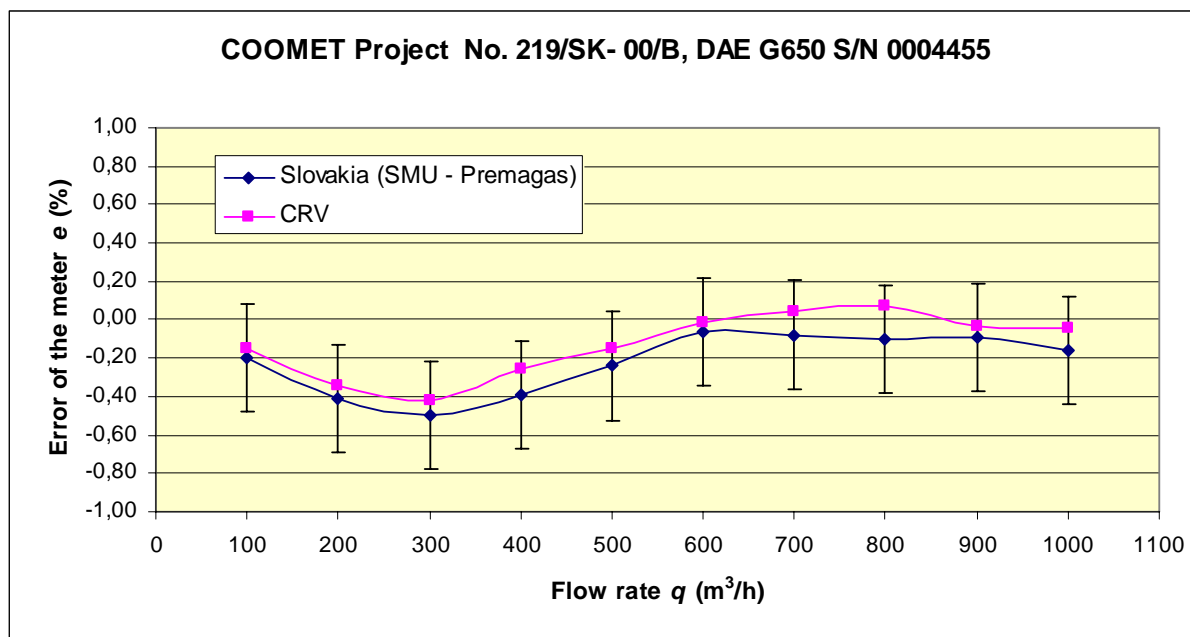

6.4.2 Slovakia – AMS, SPP inc.

Flow rate	Error of the meter $x_i$	Expanded uncertainty $U_{xi}$ ( $k = 2$ )	CRV $x_{ref} = y$	Expanded uncertainty of the CRV $U_y$ ( $k = 2$ )	$d_i$	$E_i$	Result
$m^3/h$	%	%	%	%	–	–	
1000	-0,31	0,35	-0,05	0,13	-0,26	0,82	passed
900	-0,22	0,35	-0,03	0,13	-0,18	0,57	passed
800	-0,12	0,35	0,07	0,11	-0,19	0,59	passed
700	-0,13	0,35	0,05	0,11	-0,18	0,55	passed
600	-0,10	0,35	-0,01	0,11	-0,09	0,27	passed
500	-0,25	0,35	-0,15	0,11	-0,10	0,31	passed
400	-0,46	0,35	-0,26	0,11	-0,20	0,60	passed
300	-0,68	0,35	-0,42	0,11	-0,25	0,78	passed
200	-0,49	0,35	-0,34	0,11	-0,15	0,45	passed
100	-0,16	0,35	-0,15	0,11	-0,01	0,04	passed
<b>Mean</b>					<b>-0,16</b>	<b>0,50</b>	<b>passed</b>

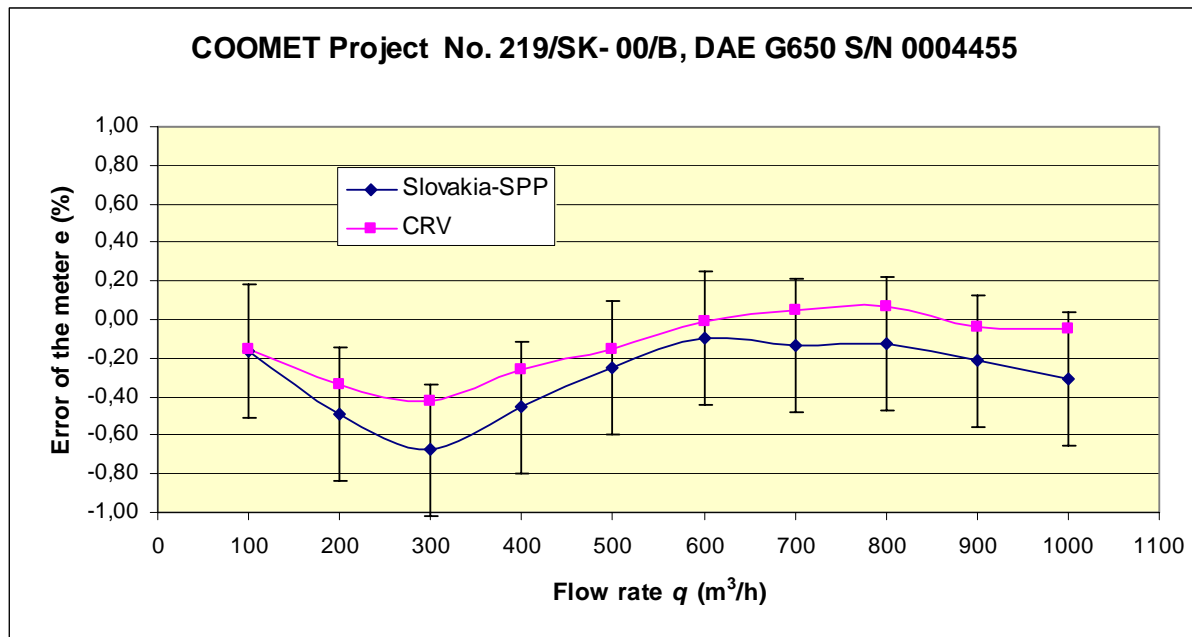

6.4.3 Lithuania – LEI

Flow rate	Error of the meter $x_i$	Expanded uncertainty $U_{x_i}$ ( $k = 2$ )	CRV $x_{ref} = y$	Expanded uncertainty of the CRV $U_y$ ( $k = 2$ )	$d_i$	$E_i$	Result
m <sup>3</sup> /h	%	%	%	%	–	–	
1000	-0,11	0,34	-0,05	0,13	-0,06	0,20	passed
900	-0,03	0,34	-0,03	0,13	0,00	0,01	passed
800	0,03	0,34	0,07	0,11	-0,04	0,12	passed
700	0,03	0,34	0,05	0,11	-0,02	0,05	passed
600	-0,04	0,34	-0,01	0,11	-0,03	0,09	passed
500	-0,17	0,34	-0,15	0,11	-0,02	0,05	passed
400	-0,36	0,34	-0,26	0,11	-0,10	0,32	passed
300	-0,49	0,34	-0,42	0,11	-0,07	0,21	passed
200	-0,33	0,34	-0,34	0,11	0,01	0,03	passed
100	0,21	0,35	-0,15	0,11	0,36	1,07	warning
				<b>Mean</b>	<b>0,004</b>	<b>0,22</b>	<b>passed</b>

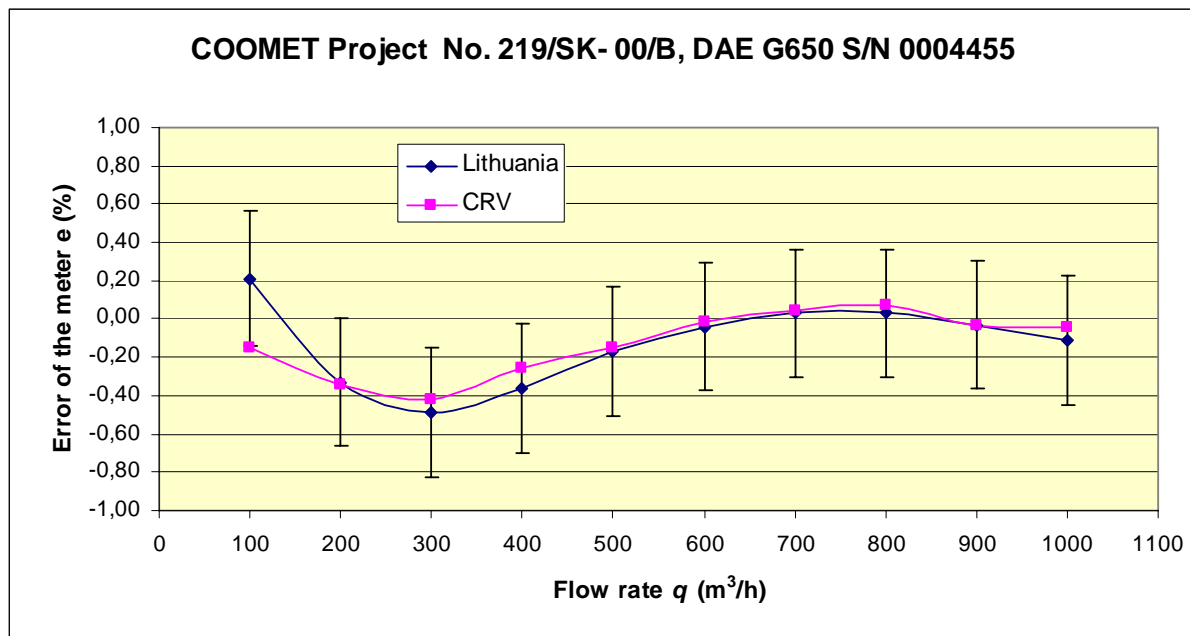

## 7 Degree of equivalence evaluation between participating laboratories

For a more detailed depiction of relations among the participating laboratories, we prepared outcomes of comparison measurements, which bring an information on quality of metrology assurance and uniformity of measurements in the region of operation of participating laboratories.

As already stated in the chapter 5.2, on this part of the project, 4 independent laboratories took part: German, Belorussia, Russia and Ukraine. In tables which follow further, they are marked with „Indep“.

Three laboratories, which took part in comparison measurements are dependent (their primary meters are traceable on an independent laboratory) from German laboratory PTB. Those are Slovak SMU-Premagas, Slovak SPP and Lithuania. In tables which follow further, they are marked with „PTB“.

The degree of equivalence between laboratory  $i$  and  $j$  was calculated as the pair of values  $d_{ij}$  and  $E_{ij}$ , calculated according equation (16) and (20) (see chapter 6.1.2 B). The method of examination of limits is the same as per in final the chapter 6.1.2 A. The calculated pair of values  $d_{ij}$  and  $E_{ij}$ , are mentioned down in tables.

**They are signed as red if  $E_{ij} > 1,2$ .** It means that the mutual degree of equivalence of laboratories  $i$  and  $j$  is failed.

**They are signed as orange if  $1,2 \geq E_{ij} > 1$ .** It means that the mutual degree of equivalence of laboratories  $i$  and  $j$  is in warning level.

They are signed as black if  $E_{ij}$  is equal or less than 1. It means that the mutual degree of equivalence of laboratories  $i$  and  $j$  is satisfactory.

Flow rate	Belarus - Lithuania (Indep/PTB)		Belarus - Germany (Indep/Indep)		Belarus - Rusko (Indep/Indep)		Belarus – Slovakia (Premagas) (Indep/PTB)		Belarus - Slovakia (SPP) (Indep/PTB)		Belarus - Ukraine (Indep/Indep)	
	$d_{ij}$	$E_{ij}$	$d_{ij}$	$E_{ij}$	$d_{ij}$	$E_{ij}$	$d_{ij}$	$E_{ij}$	$d_{ij}$	$E_{ij}$	$d_{ij}$	$E_{ij}$
1000	–	–	–	–	–	–	–	–	–	–	–	–
900	–	–	–	–	–	–	–	–	–	–	–	–
800	–	–	–	–	–	–	–	–	–	–	–	–
700	–	–	–	–	–	–	–	–	–	–	–	–
600	–	–	–	–	–	–	–	–	–	–	–	–
500	–	–	–	–	–	–	–	–	–	–	–	–
400	0,42	0,91	0,41	1,18	0,32	0,81	0,45	1,06	0,52	1,10	0,26	0,64
300	0,11	0,20	0,10	0,29	0,02	0,04	0,12	0,23	0,30	0,54	-0,08	0,16
200	0,07	0,14	0,14	0,39	0,01	0,02	0,15	0,33	0,23	0,46	0,04	0,09
100	-0,56	1,10	-0,16	0,46	-0,27	0,62	-0,16	0,34	-0,19	0,37	-0,33	0,74
<b>Mean</b>	<b>0,01</b>	<b>0,59</b>	<b>0,12</b>	<b>0,58</b>	<b>0,02</b>	<b>0,37</b>	<b>0,14</b>	<b>0,49</b>	<b>0,21</b>	<b>0,62</b>	<b>-0,03</b>	<b>0,41</b>

Flow rate $q$ (m <sup>3</sup> /h)	Lithuania - Germany (PTB/Indep)		Lithuania - Russia (PTB/Indep)		Lithuania – Slovakia (Premagas) (PTB/PTB)		Lithuania – Slovakia (SPP) (PTB/PTB)		Lithuania - Ukraine (PTB/Indep)		Germany - Russia (Indep/Indep)	
	<i>dij</i>	<i>Eij</i>	<i>dij</i>	<i>Eij</i>	<i>dij</i>	<i>Eij</i>	<i>dij</i>	<i>Eij</i>	<i>dij</i>	<i>Eij</i>	<i>dij</i>	<i>Eij</i>
1000	-0,01	0,03	-0,49	1,19	0,05	0,12	0,20	0,44	-0,21	0,50	-0,48	1,69
900	0,02	0,07	-0,35	0,85	0,06	0,15	0,19	0,40	-0,05	0,12	-0,37	1,32
800	0,04	0,12	-0,23	0,56	0,13	0,30	0,15	0,32	-0,05	0,12	-0,27	0,96
700	0,06	0,17	-0,19	0,46	0,11	0,25	0,16	0,34	-0,04	0,09	-0,25	0,89
600	0,04	0,12	-0,18	0,44	0,02	0,05	0,06	0,13	-0,05	0,12	-0,22	0,79
500	0,04	0,10	-0,12	0,29	0,07	0,16	0,08	0,17	-0,05	0,12	-0,16	0,55
400	-0,01	0,02	-0,10	0,24	0,03	0,07	0,10	0,21	-0,16	0,38	-0,09	0,33
300	-0,01	0,02	-0,09	0,22	0,01	0,02	0,19	0,41	-0,19	0,45	-0,08	0,29
200	0,07	0,18	-0,06	0,15	0,08	0,18	0,16	0,33	-0,03	0,07	-0,13	0,45
100	0,40	1,04	0,29	0,68	0,41	0,89	0,37	0,75	0,23	0,53	-0,11	0,39
<b>Mean</b>	<b>0,07</b>	<b>0,19</b>	<b>-0,15</b>	<b>0,51</b>	<b>0,10</b>	<b>0,22</b>	<b>0,17</b>	<b>0,35</b>	<b>-0,06</b>	<b>0,25</b>	<b>-0,22</b>	<b>0,77</b>

Flow rate $q$ (m <sup>3</sup> /h)	Germany - Slovakia (Premagas) (Indep/PTB)		Germany - Slovakia (SPP) (Indep/PTB)		Germany - Ukraine (Indep/Indep)		Russia - Slovakia (Premagas) (Indep/PTB)		Russia - Slovakia (SPP) (Indep/PTB)		Russia - Ukraine (Indep/Indep)	
	<i>dij</i>	<i>Eij</i>	<i>dij</i>	<i>Eij</i>	<i>dij</i>	<i>Eij</i>	<i>dij</i>	<i>Eij</i>	<i>dij</i>	<i>Eij</i>	<i>dij</i>	<i>Eij</i>
1000	0,06	0,13	0,21	0,42	-0,20	0,67	0,54	1,46	0,69	1,64	0,28	0,80
900	0,04	0,08	0,16	0,32	-0,07	0,25	0,41	1,12	0,54	1,28	0,30	0,86
800	0,09	0,18	0,11	0,22	-0,09	0,31	0,36	0,98	0,38	0,92	0,18	0,51
700	0,04	0,09	0,10	0,19	-0,10	0,35	0,30	0,81	0,35	0,84	0,15	0,43
600	-0,02	0,04	0,02	0,03	-0,09	0,31	0,20	0,55	0,24	0,57	0,13	0,37
500	0,03	0,07	0,05	0,09	-0,09	0,29	0,19	0,51	0,20	0,48	0,07	0,20
400	0,04	0,08	0,10	0,21	-0,15	0,51	0,13	0,35	0,20	0,47	-0,06	0,17
300	0,01	0,03	0,19	0,39	-0,18	0,61	0,10	0,26	0,28	0,66	-0,10	0,29
200	0,01	0,03	0,09	0,17	-0,10	0,33	0,14	0,38	0,22	0,52	0,03	0,09
100	0,01	0,01	-0,03	0,05	-0,17	0,57	0,12	0,31	0,08	0,20	-0,06	0,17
<b>Mean</b>	<b>0,03</b>	<b>0,08</b>	<b>0,10</b>	<b>0,21</b>	<b>-0,13</b>	<b>0,42</b>	<b>0,25</b>	<b>0,67</b>	<b>0,32</b>	<b>0,76</b>	<b>0,09</b>	<b>0,39</b>

Flow rate $q$ (m <sup>3</sup> /h)	Slovakia (Premagas)-Slovakia (SPP) (PTB/PTB)		Slovakia (Premagas)-Ukraine (PTB/Indep)		Slovakia (SPP) - Ukraine (PTB/Indep)	
	<i>dij</i>	<i>Eij</i>	<i>dij</i>	<i>Eij</i>	<i>dij</i>	<i>Eij</i>
1000	0,15	0,36	-0,26	0,68	-0,41	0,95
900	0,12	0,29	-0,11	0,30	-0,24	0,55
800	0,02	0,06	-0,18	0,47	-0,20	0,48
700	0,05	0,12	-0,15	0,39	-0,20	0,47
600	0,04	0,09	-0,07	0,19	-0,11	0,26
500	0,01	0,03	-0,12	0,32	-0,13	0,31
400	0,07	0,16	-0,19	0,50	-0,26	0,60
300	0,18	0,43	-0,20	0,52	-0,38	0,88
200	0,08	0,17	-0,11	0,29	-0,19	0,44
100	-0,03	0,07	-0,18	0,46	-0,14	0,33
<b>Mean</b>	<b>0,07</b>	<b>0,18</b>	<b>-0,16</b>	<b>0,41</b>	<b>-0,23</b>	<b>0,53</b>

## 8 Summary and conclusion

The results of comparison measurements of COOMET project No. 219/Sk-00 for „B“ level are stated in a summary form in the following table.

<b>Comparison meter, turbine gasmeter type DAE size G650, SN 0004455</b>							
Flow rate $q$ (m <sup>3</sup> /h)	Independent laboratories				Dependent laboratories		
	Germany	Belarus	Russia	Ukraine	Lithuania	Slovakia SMU (Premagas)	Slovakia SPP
1000	passed	–	failed	passed	passed	passed	passed
900	passed	–	failed	passed	passed	passed	passed
800	passed	–	passed	passed	passed	passed	passed
700	passed	–	passed	passed	passed	passed	passed
600	passed	–	passed	passed	passed	passed	passed
500	passed	–	passed	passed	passed	passed	passed
400	passed	warning	passed	passed	passed	passed	passed
300	passed	passed	passed	passed	passed	passed	passed
200	passed	passed	passed	passed	passed	passed	passed
100	passed	passed	passed	passed	warning	passed	passed
<b>Evaluation</b>	<b>passed</b>	<b>passed</b>	<b>passed</b>	<b>passed</b>	<b>passed</b>	<b>passed</b>	<b>passed</b>

In the following table, we made analysis of the outcomes of comparison measurement. It consists of percent interpretation of accomplishments of measurements achieved by participating laboratories in relationship to a reference value.

<b>Analysis of results</b>							
Evaluation	Independent laboratories				Dependent laboratories		
	Germany	Belarus	Russia	Ukraine	Lithuania	Slovakia SMU (Premagas)	Slovakia SPP
Results of equivalence	<b>10</b>	<b>3</b>	<b>8</b>	<b>10</b>	<b>9</b>	<b>10</b>	<b>10</b>
Results with warning	<b>0</b>	<b>1</b>	<b>0</b>	<b>0</b>	<b>1</b>	<b>0</b>	<b>0</b>
Results of non-equivalence	<b>0</b>	<b>0</b>	<b>2</b>	<b>0</b>	<b>0</b>	<b>0</b>	<b>0</b>
Number of measurement point of flow rate	10	4	10	10	10	10	10
Percentage of successfully	100 %	75 %	80 %	100 %	90 %	100 %	100 %

In the following table, there is a summary of mean value  $E_i$  calculated according to an equation (15) and mean values of  $E_{ij}$  calculated according to equation (20). Values of  $E_i$  parameter are given in the diagonal of the table in bold. Values of  $E_{ij}$  parameter are given in the cells for the couples of compared laboratories. Values the laboratory of Belarus are at the end of tables because they did not take part in the whole measured scale of flow.



On a basis of these results, obtained in participating laboratories it is possible to state that the first comparison measurement in this area in regional organization of COOMET ever achieved an excellent results (save for one laboratory, where it is necessary to analyze the results achieved). In laboratories, where there are no CMC tables, which would represent their measuring capability this comparison measurement may serve as an impulse for their elaboration. This project should serve as a help for these laboratories in order they can use the outcomes of measurements and experience gained in the process in a creation of system of quality.