

Final Report

APMP.EM-K4.1

APMP Key Comparison of Capacitance at 10 pF

H. L. Johnson

National Measurement Institute, Australia

February 09

Contents

1	Introduction	5
2	Participants and organisation of the comparison	6
2.1	List of participants	6
2.2	Comparison schedule	6
2.3	Organisation of the comparison	6
2.4	Unexpected incidents	7
2.4.1	Non-steady behaviour of the artefact necessitating repetition of Loop 1	7
2.4.2	Other incidents	8
3	Travelling standard and measurement instructions	9
3.1	Description of the standards	9
3.2	Quantities to be measured and conditions of measurements	9
3.3	Measurement instructions	9
3.4	Deviations from the protocol	9
4	Methods of measurement	10
5	Measurements of the pilot laboratory	11
5.1	Sensitivity of the travelling standards	11
5.2	Stability of the travelling standards	11
5.3	Calculation of reference values	12
6	Measurement results	14
6.1	Normalization of results	14
6.2	Results of the participating institutes	14
6.3	Calculation of the reference value and its uncertainty	15
6.4	Degrees of equivalence	15
6.4.1	Degrees of equivalence of the participating institutes with respect to the comparison reference values	15
6.4.2	Pair-wise degrees of equivalence	17
6.5	Proposal for linking to CCEM-K4 key comparison and degrees of equivalence	17
6.5.1	Method of calculation of linking correction	17
6.5.2	Information from linking laboratories	18
6.5.3	Calculated linking correction	18
6.5.4	Degrees of equivalence with respect to CCEM-K4 key comparison reference value	19
6.5.5	Proposal for calculation of pair-wise degrees of equivalence $D_{i,j}$	20
7	Withdrawals or changes of results	21
8	Requests for follow up bilateral comparisons	21
9	Summary and conclusions	21
10	Appendices	22
	Appendix A: Degrees of equivalence	22
	Appendix B: Methods of measurement	25

B.1	Method of measurement: CMS, Taiwan	25
B.2	Method of measurement: KIM-LIPI, Indonesia	25
B.3	Method of measurement: KRISS, Korea	26
B.4	Method of measurement: NIM, China	27
B.5	Method of measurement: NIMT, Thailand	27
B.6	Method of measurement: NMI, Australia	28
B.7	Method of measurement: NMIJ/AIST, Japan	28
B.8	Method of measurement: NMISA, South Africa	28
B.9	Method of measurement: NPL, India	29
B.10	Method of measurement: SCL, Hong Kong	29
B.11	Method of measurement: SIRIM, Malaysia	29
B.12	Method of measurement: A*STAR, Singapore	30
B.13	Method of measurement: VNIIM, Russia	30
Appendix C: Uncertainty statements		32
C.1	Uncertainty statement: CMS, Taiwan	32
C.2	Uncertainty statement: KIM-LIPI, Indonesia	32
C.3	Uncertainty statement: KRISS, Korea	33
C.4	Uncertainty statement: NIM, China	33
C.5	Uncertainty statement: NIMT, Thailand	34
C.6	Uncertainty statement: NMI, Australia	35
C.7	Uncertainty statement: NMIJ/AIST, Japan	36
C.8	Uncertainty statement: NMISA, South Africa	36
C.9	Uncertainty statement: NPL, India	37
C.10	Uncertainty statement: SCL, Hong Kong	37
C.11	Uncertainty statement: SIRIM, Malaysia	38
C.12	Uncertainty statement: A*STAR, Singapore	39
C.13	Uncertainty statement: VNIIM, Russia	40
Appendix D: Optional measurements: Dissipation factor		41
Appendix E: Additional details of the calculation of pair-wise degrees of equivalence within APMP.EM-K4.1		41
E.1	Estimating the covariance due to derived traceability	41
E.2	Estimating the covariance due to common technique	41
E.3	Treating the correlation arising from the normalisation of participants results	42
E.4	Summary of values used in calculation	43
Appendix F: References		44
Appendix G: Comparison protocol		44

Figures

Figure 2-1 Pilot laboratory measurements of artefact	8
Figure 5-1 Repeated measurements of pilot laboratory of the comparison artefact at a measurement frequency of 1592 Hz and measuring voltage of 100 Vrms.	12
Figure 6-1 Degrees of equivalence d_i of the participating institutes with respect to the comparison reference value.	16

Tables

Table 2-1 List of participants.....	6
Table 2-2 Comparison schedule.....	7
Table 4-1 Participants' method of measurement and traceability.	10
Table 5-1 Values required for calculation of reference values.	13
Table 6-1 Results of participating institutes. See text for definition of symbols.....	14
Table 6-2 Degrees of equivalence of the participating institutes relative to the comparison reference value.	16
Table 6-3 Summary of changes to the method of measurement used in CCEM-K4 and APMP.EM-K4.1 by VNIIM.....	18
Table 6-4 CCEM-K4 and APMP.EM-K4.1 comparison results and standard uncertainties for linking laboratories.	19
Table 6-5 Proposed degrees of equivalence of the participating institutes relative to the CCEM key comparison reference value.	20

1 Introduction

A key comparison of capacitance at 10 pF and a supplementary comparison of capacitance at 100 pF have been conducted between participating APMP member laboratories. The aim of these comparisons is to provide participating laboratories with the opportunity to compare national standards of capacitance within the region, and to support participants' entries in Appendix C of the Mutual Recognition Arrangement [1]. Results of the key comparison are reported here. Results of the supplementary comparison are reported separately.

It is proposed that the values from this key comparison in the APMP region be linked to the international key comparison CCEM-K4 carried out between 1994 and 1996, with NMIA (Australia), NIM (China) and VNIIM (Russian Federation) as linking laboratories.

The Andeen-Hagerling AH11A fused-silica capacitance standards used in this comparison were kindly supplied by the National Metrology Institute of Japan, AIST.

The assistance of the support group (Dr. Sze Wey Chua, A*STAR Singapore, Dr Rae Duk Lee, KRISS Korea and Mr Andrew Corney, MSL New Zealand) is gratefully acknowledged.

2 Participants and organisation of the comparison

2.1 List of participants

Thirteen laboratories participated in the comparison, as listed in Table 2-1.

	Organisation	Acronym	State or Economy
1	Center for Measurement Standards	CMS	Taiwan
2	Pusat Penelitian Kalibrasi Instrumentasi Metrologi - LIPI	KIM-LIPI	Indonesia
3	Korea Research Institute of Standards and Science	KRISS	Korea
4	National Institute of Metrology	NIM	China
5	National Institute of Metrology (Thailand)	NIMT	Thailand
6	National Measurement Institute of Australia*	NMIA	Australia
7	National Metrology Institute of Japan, AIST	NMIJ/AIST	Japan
8	National Metrology Institute of South Africa†	NMISA	South Africa
9	National Physical Laboratory	NPLI	India
10	Standards and Calibration Laboratory	SCL	Hong Kong
11	Standards and Industrial Research Institute of Malaysia	SIRIM	Malaysia
12	Agency for Science, Technology and Research	A*STAR	Singapore
13	D. I. Mendeleev Institute for Metrology	VNIIM	Russia

Table 2-1 List of participants.

2.2 Comparison schedule

The comparison schedule is given in Table 2-2.

2.3 Organisation of the comparison

The comparison schedule was initially organised in four consecutive loops (Loops 1 to 4) with between two and four participants in each loop. The artefacts returned to the pilot laboratory, NMIA, for measurement at the conclusion of each loop. Due to concerns about the behaviour of the 10 pF artefact during Loop 1, an additional loop was organised (Loop 5) to allow Loop 1 participants to repeat their measurements (see Section 2.4.1 for further details).

A total of four weeks was scheduled for each participant. Generally participants had at least two weeks and usually three weeks in which to make their measurements, depending on the time taken to clear the artefacts through the customs service in their country and allow the artefacts to settle in their laboratory.

The artefacts were transported in an aluminium case by air using an ATA Carnet for customs clearance where possible. A shock monitor was attached to the outside of the transport case and to the back panel of the artefact enclosure.

* Formerly National Measurement Laboratory, CSIRO (CSIRO-NML)

† Formerly National Measurement Laboratory, CSIR (CSIR-NML)

Loop No.	Participant	Standards in laboratory		Mean measurement date(s)	Comments
		From:	To:		
-	NMIA	28 Apr 2003	05 Jan 2004	14 Jun 2003 10 Sep 2003 16 Dec 2003	Initial characterisation of standards.
1	NMIJ/AIST	16 Jan 2004	06 Feb 2004	27 Jan 2004	
1	KRISS	17 Feb 2004	04 Mar 2004	27 Feb 2004	
1	A*STAR	10 Mar 2004	05 Apr 2004	26 Mar 2004(a) 28 Mar 2004(b)	(a) 1000 Hz (b) 1592 Hz
1	CMS	09 Apr 2004	06 May 2004	26 Apr 2004	
1	NMIA	10 May 2004	01 Jul 2004	18 May 2004 20 Jun 2004	Second set of measurements taken as change in drift rate of capacitor suspected.
2	NPLI	10 Jul 2004	28 Jul 2004	19 Jul 2004	Observed change in value of 10 pF capacitor of 0.28 $\mu\text{F}/\text{F}$ on 26 Jul 2006.
2	NIMT	10 Aug 2004	23 Aug 2004	16 Aug 2004	
2	NMISA	03 Sep 2004	21 Sep 2004	17 Sep 2004	
2	NMIA	27 Sep 2004	25 Oct 2004	6 Oct 2004	
3	SIRIM	27 Oct 2004	15 Nov 2004	12 Nov 2004	
3	SCL	20 Nov 2004	11 Dec 2004	28 Nov 2004	
3	KIM-LIPI	28 Dec 2004	10 Jan 2005	4 Jan 2005	
3	NMIA	20 Jan 2005	7 Mar 2005	03 Feb 2005 26 Feb 2005	
4	NIM	14 Mar 2005	05 Apr 2005	29 Mar 2005	
4	VNIIM	03 Jun 2005	Sep 2005	18 Aug 2005	
4	NMIA	16 Sep 2005	19 Jan 2006	07 Oct 2005 12 Jan 2006	Standards measured at conclusion of Loop 4 and at start of Loop 5.
5	KRISS	02 Feb 2006	21 Feb 2006	11 Feb 2006	
5	A*STAR	24 Feb 2006	17 Mar 2006	11 Mar 2006	
5	NMIJ/AIST	26 Mar 2006	14 Apr 2006	4 Apr 2006	
5	CMS	19 Apr 2006	15 May 2006	8 May 2006	
5	NMIA	22 May 2006		27 May 2006	

Table 2-2 Comparison schedule.

2.4 Unexpected incidents

A number of unexpected incidents occurred during the course of the comparison. These are described below.

2.4.1 Non-steady behaviour of the artefact necessitating repetition of Loop 1

The pilot laboratory measurements of the artefact are shown in Figure 2-1. Measurements over a period of approximately six months prior to the start of the comparison showed a steady linear increase in the value of the artefact of approximately $+0.2 \mu\text{F}/\text{F}$ per year. Pilot laboratory measurements following Loop 1 of the comparison showed an unexpected decrease in the value of the artefact. For this reason, the pilot laboratory remeasured the comparison artefact, delaying the start of Loop 2. Subsequent measurements by the pilot laboratory during the remainder of the comparison showed an approximately linear decrease in the value of the artefact at a rate of $-0.1 \mu\text{F}/\text{F}$ per year.

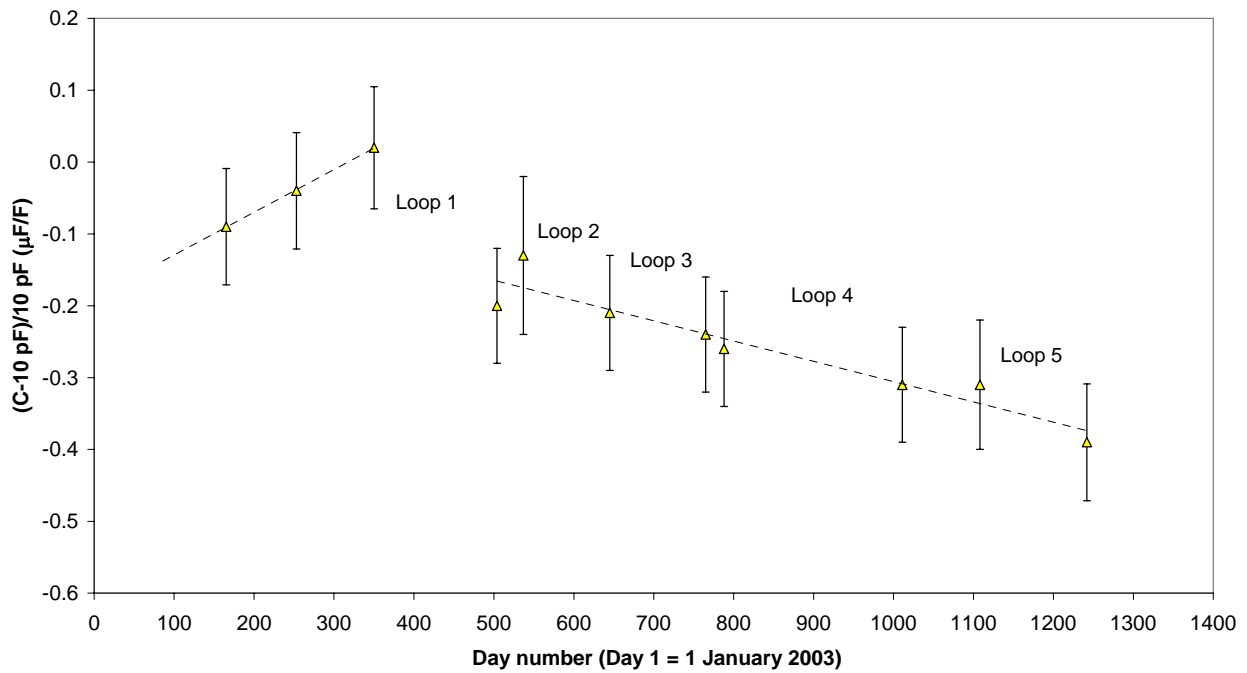

Figure 2-1 Pilot laboratory measurements of artefact.

By the end of the scheduled comparison measurements it was clear that the behaviour of the artefact during Loop 1 would significantly increase the uncertainty of the comparison if allowed to stand. For this reason, and with the agreement of all participants, it was decided that participants in Loop 1 would repeat their measurements in an additional loop (Loop 5).

The cause of the non-steady behaviour of the artefact is not clear. Neither the shock monitor attached to the outside of the transport case nor the shock monitor attached to the back panel of the artefact enclosure was activated. Ambient conditions were not monitored during transportation of the artefacts, so temperature cycling effects cannot be ruled out. Closer monitoring of ambient conditions during transport of Andeen-Hagerling AH11A fused silica capacitance standards used in comparisons may be desirable. Note that the accompanying 100 pF artefact used for the supplementary comparison (separately reported) did not show any significant deviations from a steady linear drift rate during the whole of the comparison.

2.4.2 Other incidents

A four month delay to the comparison schedule occurred in Loop 4 during the measurement period assigned to VNIIM. This was in addition to the extra four weeks that was allowed for customs clearance in and out of Russia.

The shock monitor attached to the outside of the transport case was activated during shipment from KRISS to A*STAR in Loop 5. The shock monitor attached to the back panel of the artefact enclosure was not activated. No damage to the artefacts or changes in behaviour of the artefacts was noted.

3 Travelling standard and measurement instructions

3.1 Description of the standards

The travelling standard was a 10 pF Andeen-Hagerling AH11A fused silica capacitance standard mounted in a AH1100 capacitance standard frame. A second Andeen-Hagerling AH11A fused silica capacitance standard mounted in the same AH1100 capacitance standard frame was used for the supplementary comparison at 100 pF (reported separately). The AH1100 frame is a standard-width bench-top or rack-mountable frame. The AH11A capacitance standard includes a temperature-controlled oven that is powered via the AH1100 frame. The frame also monitors internal power voltages and temperatures.

The capacitor is fitted with BNC co-axial terminations. Co-axial measuring leads with BNC to MUSA connectors were supplied with the capacitor, together with MUSA-GR874 adapters and MUSA-BNC adapters.

3.2 Quantities to be measured and conditions of measurements

The capacitance of the capacitor **at the terminals on the AH1100 frame** was measured. The preferred measuring voltage was 100 V(rms). The preferred measurement frequency was 1592 Hz ($\omega = 10^4 \text{ rad}\cdot\text{s}^{-1}$). Measurements at a frequency of 1000 Hz were permitted instead of, or as well as, 1592 Hz. Measurement of the dissipation factor was optional.

The comparison measurand m_n is defined as the n th comparison measurement of the fractional difference of the measured capacitance, C_n , from the nominal value of the capacitor, C , calculated as:

$$m_n = \frac{C_n}{C} - 1. \quad (1)$$

The subscript n denoting the measurement number should not be confused with the subscript i , which is introduced in Section 6.4 and denotes the participating laboratory.

Participants were asked to report the drift and chassis temperature readings for each capacitor, and the ambient temperature, for monitoring purposes.

3.3 Measurement instructions

The AH 1100/11A Operation and Maintenance Manual was included with the shipment of the travelling standards. The comparison protocol encouraged participants to leave the standards to stabilise for two to three days before measurement.

3.4 Deviations from the protocol

The protocol did not specify the value of the von Klitzing constant to be used in the comparison, and consequently participants took a variety of approaches. After consultation, it was decided that participants would resubmit their results based on R_{K-90} and including its associated uncertainty.

4 Methods of measurement

Table 4-1 lists the method of measurement used by each participant and the traceability route to the SI. Further details are given in Appendix B.

Participant	Traceability	Measurement Method		
		Bridge	Technique	Reference standard
CMS	DC QHR	10:1 ratio transformer (4TP)	Comparison	100 pF
KIM-LIPI	NMIA (Melbourne Branch)	GR1621A	Comparison	100 pF
KRISS	BIPM [†] , CENAM [‡] , NIST [§] , NMIA, VNIIM	10:1 ratio transformer	Substitution	10 pF
NIM	Calculable capacitor	1:1 ratio transformer	Comparison	10 pF
NIMT	PTB ^{**}	GR1620	Comparison	10 pF
NMIA	Calculable capacitor	10:1 ratio transformer	Comparison	100 pF
NMIJ/AIST	DC QHR	Capacitance bridge (2TP)	Substitution	10 pF
NMISA	BIPM [†]	AH2500A	Substitution	10 pF
NPLI	Calculable capacitor	10:1 ratio transformer	Substitution	10 pF
SCL	NPL [*]	AH2500A	Substitution	10 pF
SIRIM	BIPM [†]	GR1615A	Comparison	10 pF
A*STAR	NPL [*]	GR1621A	Substitution	10 pF
VNIIM	Calculable capacitor	10:1 ratio transformer	Substitution	10 pF

Table 4-1 Participants' method of measurement and traceability.

[†] International Bureau of Weights and Measures

[‡] Centro Nacional de Metrología, Mexico.

[§] National Institute of Standards and Technology, USA

^{*} National Physical Laboratory, UK.

^{**} Physikalisch Technische Bundesanstalt, Germany

5 Measurements of the pilot laboratory

Measurements made by the pilot laboratory were used to assess the stability of the travelling standard during the course of the comparison. Assessment of the sensitivity of the standard to ambient temperature, temperature cycling, measurement voltage, and measurement frequency was based on the manufacturer's specifications as well as pilot laboratory measurements.

5.1 Sensitivity of the travelling standards

AH11A capacitance standards have a low sensitivity to changes in ambient temperature due to an internal temperature-controlled oven. The manufacturer's specification for the temperature coefficient with respect to changes in ambient temperature is $0.01 \mu\text{F}/\text{F } ^\circ\text{C}^{-1}$. Pilot laboratory measurements confirm that the temperature coefficient for the travelling standard is no greater than this value. The protocol requested participants not to make corrections for ambient laboratory temperature, but suggested that an uncertainty component for ambient laboratory temperatures differing from $20 \text{ }^\circ\text{C}$ could be included in the uncertainty statement.

The manufacturer's specification for the sensitivity of the AH11A standard to temperature cycling and to mechanical shock is $0.05 \mu\text{F}/\text{F}$. Temperature cycling of the travelling standard under laboratory conditions by the pilot laboratory caused changes of this order of magnitude. The travelling standard was shipped un-powered in all cases so that hysteresis due to temperature cycling and to mechanical shock contributes to the scatter in the measurements of the pilot laboratory and need not be separately treated.

The manufacturer's specification for the sensitivity of the AH11A standard to ac measurement voltage is $0.003 \mu\text{F}/\text{F } \text{V}^{-1}$ at 1 kHz. Pilot laboratory measurements of the travelling standard at 1592 Hz could not detect a sensitivity to measurement voltage. We conclude that the sensitivity of the travelling standards to ac measurement voltage is less than $0.0003 \mu\text{F}/\text{F } \text{V}^{-1}$ at 1592 Hz. No correction is made to measurements made at voltages other than the $100 \text{ V}_{\text{rms}}$ specified in the comparison protocol, but an uncertainty component is included where appropriate.

The capacitance change when the frequency is increased from 1000 Hz to 1592 Hz was measured by the pilot laboratory to be $-0.063 \mu\text{F}/\text{F}$, with a standard uncertainty of $0.013 \mu\text{F}/\text{F}$.

5.2 Stability of the travelling standards

Measurements by the pilot laboratory were made at 1592 Hz before the start of the comparison and at the conclusion of each measurement loop. Measurements of the travelling standard prior to Loop 2 are excluded from analysis for reasons discussed in Section 2.4.1.

Pilot laboratory measurements at 1592 Hz are given in Table 6-1 and plotted in Figure 5-1. Weighted linear regression using the standard uncertainty of the measurement as weight was performed on each set of data (refer to Table 5-1 for details of the fit parameters). The Birge ratio, R_B , is a measure of self-consistency in a set of measurements (see, for example, [2]). The value computed for the pilot laboratory dataset was $R_B = 0.1$ with $u(R_B) = 1.8$. It is concluded that the criterion for self consistency, $R_B = 1 \pm u(R_B)$, is met, and that the behaviour of the standard can be adequately described by a linear drift with time.

Additional measurements made by the pilot laboratory of the frequency difference are used to derive reference values at 1000 Hz using the drift rate determined at 1592 Hz.

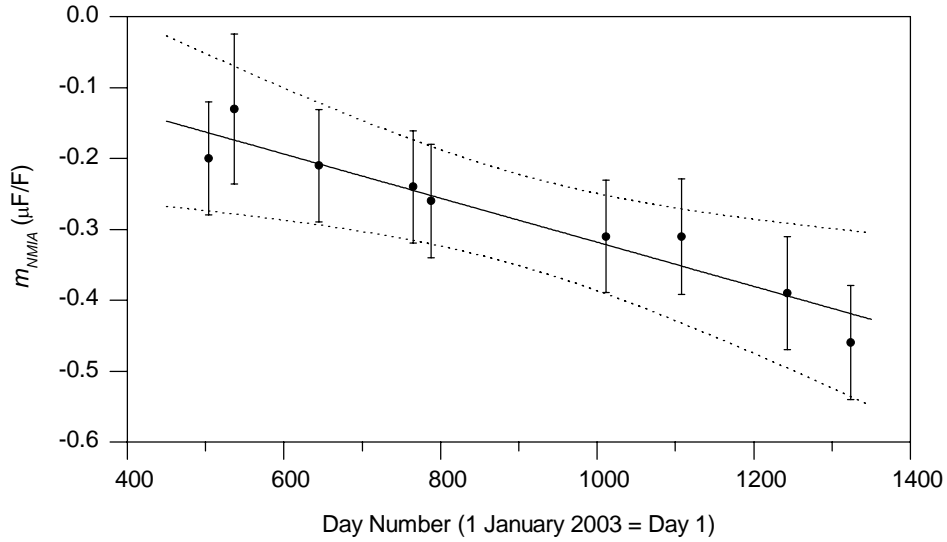

Figure 5-1 Repeated measurements of pilot laboratory of the comparison artefact at a measurement frequency of 1592 Hz and measuring voltage of 100 Vrms. Uncertainty bars represent expanded uncertainty. Solid line: line of best fit (weighted linear regression), dashed lines: prediction bands (expanded uncertainty of predicted values).

5.3 Calculation of reference values

The predicted or reference value, p_n , for each capacitor at the time of the n th measurement is calculated as:

$$p_n = a_0 + a_1 t_n + a_2 \left(\frac{1592 - f_n}{1592 - 1000} \right) + a_3 \quad (2)$$

where a_0 and a_1 are determined from the weighted linear regression described in Section 5.2, a_2 is related to the frequency coefficient of capacitance, a_3 is the correction to ambient temperature of 20 °C, t_n is the time of the n th measurement and f_n is the measurement frequency (in Hz) for the n th measurement. Note that a_3 is taken to be zero. The uncertainty in the reference value is calculated as:

$$u^2(p_n) = u^2(a_0) + u^2(a_1) \cdot t_n^2 + 2 \cdot \text{cov}(a_0, a_1) \cdot t_n + s^2 + u^2(a_2) \cdot \left(\frac{1592 - f_n}{1592 - 1000} \right)^2 + u^2(a_3) \quad (3)$$

where $\text{cov}(a_0, a_1)$ is the mutual covariance of a_0 and a_1 , s^2 is the unbiased estimate of the population variance σ^2 of the residuals of the weighted linear regression, and the uncertainties $u(t_n)$ and $u(f_n)$ are assumed to be negligible. Note that the first four terms of (3) are derived from the linear fit to the pilot laboratory measurements. Term five relates to the frequency coefficient and the last term is the uncertainty in realising an ambient temperature of 20 °C in the pilot laboratory measurements.

The number of degrees of freedom for the reference value is calculated as:

$$v(p_n) = \frac{u^4(p_n)}{\frac{(u^2(a_0) + u^2(a_1)t_n^2 + 2 \cdot \text{cov}(a_0, a_1)t_n + s^2)^2}{l-2} + \frac{u^4(a_2) \left(\frac{1592 - f_n}{1592 - 1000} \right)^4}{v(a_2)} + \frac{u^4(a_3)}{v(a_3)}} \quad (4)$$

where l is the number of measurements used to calculate the weighted linear regression. The values of constants required for the calculation of the reference values and their uncertainty are listed in Table 5-1.

Quantity	Value	Standard uncertainty	Degrees of freedom
C_{nom}	10 pF	-	-
V_{PL}	100 V	-	-
a_0	-0.007 $\mu\text{F}/\text{F}$	0.091 $\mu\text{F}/\text{F}$	7
a_1	$-3.11 \times 10^{-4} \mu\text{F}/\text{F}$ per day	$0.97 \times 10^{-4} \mu\text{F}/\text{F}$ per day	7
$\text{cov}(a_0, a_1)$	$-8.38 \times 10^{-6} (\mu\text{F}/\text{F})^2$ per day	-	-
s	$1.16 \times 10^{-3} \mu\text{F}/\text{F}$	-	-
a_2	0.063 $\mu\text{F}/\text{F}$	0.013 $\mu\text{F}/\text{F}$	21
a_3	0 $\mu\text{F}/\text{F}$	$3.7 \times 10^{-3} \mu\text{F}/\text{F}$	8

Table 5-1 Values required for calculation of reference values.

6 Measurement results

6.1 Normalization of results

Participants' measurements were treated to account for the effect of drift and measurement conditions by subtracting the reference value for the artefact at the time of the n th measurement from the measured value m_n to give a corrected measurement value x_n , that is

$$x_n = m_n - p_n \quad (5)$$

The uncertainty in the corrected measurement value $u(x_n)$ and the associated number of degrees of freedom $\nu(x_n)$ are calculated in accordance with the ISO "Guide to the expression of uncertainty in measurement, 1st ed."

6.2 Results of the participating institutes

n	Participant	Date	f	V_{rms}	m_n	$u(m_n)$	$\nu(m_n)$	p_n	$u(p_n)$	$\nu(p_n)$	x_n	$u(x_n)$	$\nu(x_n)$
		dd/mm/y y	(Hz)	(V)	($\mu\text{F}/\text{F}$)	($\mu\text{F}/\text{F}$)		($\mu\text{F}/\text{F}$)	($\mu\text{F}/\text{F}$)		($\mu\text{F}/\text{F}$)	($\mu\text{F}/\text{F}$)	
1	NMIA	18/05/04	1592	100	-0.200	0.036	11	-0.164	0.047	7	-0.036	0.059	15
2	NMIA	20/06/04	1592	100	-0.130	0.049	13	-0.174	0.044	7	0.044	0.066	19
3	NPLI	19/07/04	1592	100	-1.240	0.380	1028	-0.183	0.042	7	-1.057	0.382	1031
4	NPLI	19/07/04	1000	100	-1.660	0.380	500	-0.120	0.044	8	-1.540	0.383	508
5	NIMT	16/08/04	1000	100	1.000	1.390	178	-0.129	0.042	9	1.129	1.391	178
6	NMISA	17/09/04	1000	10	-0.183	0.113	3.3×10^8	-0.139	0.040	9	-0.044	0.120	709
7	NMIA	6/10/04	1592	100	-0.210	0.035	9	-0.208	0.036	7	-0.002	0.051	16
8	SIRIM	12/11/04	1000	100	0.390	0.880	161	-0.156	0.037	9	0.546	0.881	162
9	SCL	28/11/04	1000	15	-3.500	4.000	490	-0.161	0.036	9	-3.339	4.000	490
10	KIM-LIPI	4/01/05	1592	100	-0.500	7.690	5.4×10^7	-0.236	0.031	7	-0.264	7.690	5.4×10^7
11	NMIA	3/02/05	1592	100	-0.240	0.035	9	-0.245	0.030	7	0.005	0.046	16
12	NMIA	26/02/05	1592	100	-0.260	0.036	10	-0.252	0.029	7	-0.008	0.046	17
13	NIM	29/03/05	1592	100	-0.278	0.110	1238	-0.262	0.028	7	-0.016	0.114	794
14	VNIIM	18/08/05	1000	98.5	-0.240	0.182	34	-0.243	0.031	10	0.003	0.185	36
15	NMIA	7/10/05	1592	100	-0.310	0.035	9	-0.322	0.029	7	0.012	0.046	16
16	NMIA	12/01/06	1592	100	-0.310	0.037	11	-0.352	0.034	7	0.042	0.050	18
17	KRISS	11/02/06	1592	100	-0.500	0.105	15	-0.361	0.036	7	-0.139	0.111	18
18	KRISS	11/02/06	1000	100	-0.420	0.104	15	-0.298	0.038	9	-0.122	0.111	19
19	A*STAR	11/03/06	1000	100	-0.700	0.480	43000	-0.307	0.040	9	-0.393	0.482	35230
20	A*STAR	11/03/06	1592	100	-0.300	0.480	43000	-0.370	0.038	7	0.070	0.481	35210
21	NMIJ/AIST	4/04/06	1592	100	-0.250	0.121	40641	-0.377	0.039	7	0.127	0.127	747
22	CMS	8/05/06	1592	90	-0.230	0.150	4169	-0.388	0.042	7	0.158	0.156	1048
23	NMIA	27/05/06	1592	100	-0.390	0.036	11	-0.394	0.043	7	0.004	0.056	15
24	NMIA	16/08/06	1592	100	-0.460	0.037	12	-0.419	0.050	7	-0.041	0.062	14

Table 6-1 Results of participating institutes. See text for definition of symbols.

6.3 Calculation of the reference value and its uncertainty

The principal results of this comparison are the pair-wise degrees of equivalence and the degrees of equivalence with respect to the Key Comparison Reference Value of CCEM-K4. Since the choice of reference value does not affect the principal results, the comparison reference value is taken to be $x_{ref} = 0 \mu\text{F}/\text{F}$ with standard uncertainty of $u(x_{ref}) = 0 \mu\text{F}/\text{F}$, with the concurrence of all participants.

Other choices considered for the comparison reference value were:

1. Simple weighted mean of all results not previously identified as discrepant,
2. Generalised weighted mean (GWM)* of all results not previously identified as discrepant,
3. GWM of results from laboratories with an independent realisation of the Farad, and
4. GWM of pilot laboratory measurements.

In all cases the calculated mean was within a few parts in 10^8 of $x_{ref} = 0 \mu\text{F}/\text{F}$ with an uncertainty less than $0.05 \mu\text{F}/\text{F}$.

6.4 Degrees of equivalence

Degrees of equivalence are reported in this section. Only one value is reported for each participating laboratory. Where laboratories made measurements at both 1592 Hz and 1000 Hz, degrees of equivalence are reported with respect to the measurement at 1592 Hz. For the pilot laboratory, degrees of equivalence are reported with respect to a generalised weighted mean of all pilot laboratory measurements.

For simplicity of notation, the subscript identifying the measurement number (n) is omitted in this section.

6.4.1 Degrees of equivalence of the participating institutes with respect to the comparison reference values

The degrees of equivalence of the i th participant with respect to the comparison reference value is calculated as

$$d_i = x_i - x_{ref} = x_i. \quad (6)$$

The expanded uncertainty associated with this result, $U(d_i)$, is calculated as $U(d_i) = k_i u(x_i)$ where k_i is chosen to give 95 % coverage based on $\nu(x_i)$. The degrees of equivalence of the participating institutes relative to the comparison reference values are tabulated in Table 6-2 and represented graphically in Figure 6-1.

* A weighted mean including treatment of inter- and intra-laboratory correlations.

Participant	d_i ($\mu\text{F}/\text{F}$)	$U(d_i)$ ($\mu\text{F}/\text{F}$)
CMS	0.158	0.306
KIM-LIPI	-0.264	15.072
KRISS	-0.139	0.233
NIM	-0.016	0.223
NIMT*	1.129	2.744
NMIA	0.005	0.104
NMIJ/AIST	0.127	0.250
NMISA*	-0.044	0.235
NPLI	-1.057	0.750
SCL*	-3.339	7.860
SIRIM*	0.546	1.739
A*STAR	0.070	0.944
VNIIM*	0.003	0.374

Table 6-2 Degrees of equivalence of the participating institutes relative to the comparison reference value.
 *Measurements made at a frequency of 1000 Hz (all other measurements at 1592 Hz).

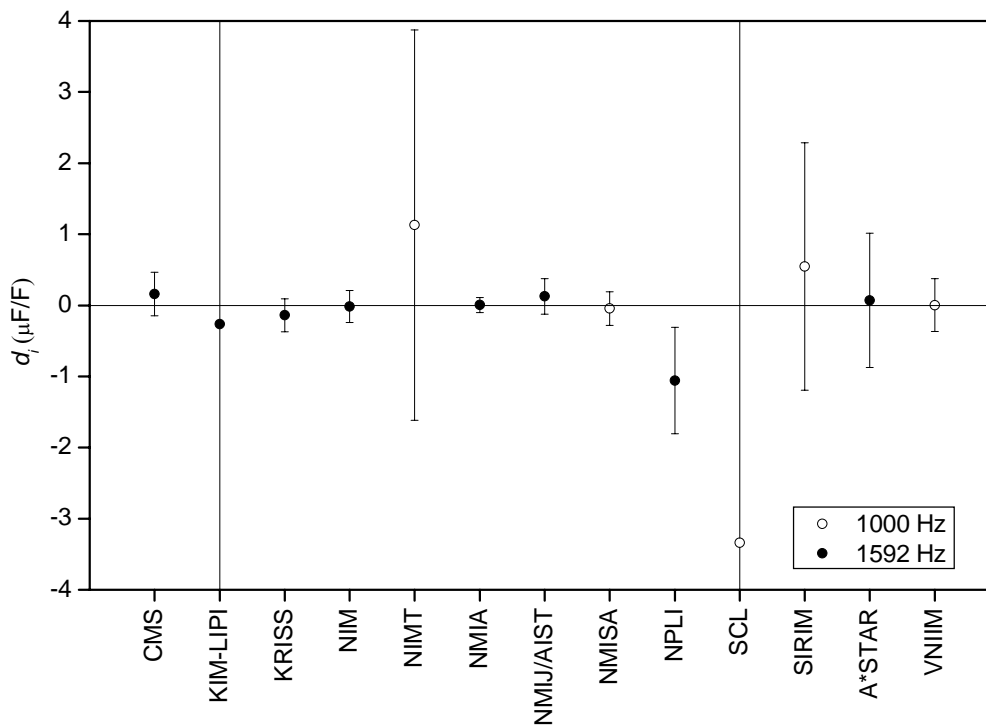

Figure 6-1 Degrees of equivalence d_i of the participating institutes with respect to the comparison reference value.
 Uncertainty bars represent the expanded uncertainty $U(d_i)$.

6.4.2 Pair-wise degrees of equivalence

Pair-wise degrees of equivalence of the participating institutes are calculated as:

$$d_{i,j} = d_i - d_j = x_i - x_j \quad (7)$$

In calculating the uncertainty associated with this result, correlations between x_i and x_j are taken into account. Let m_{ij} be the measurement bias common to measurements i and j due to a derived traceability or to a common measurement technique. Although m_{ij} is unknown, the associated uncertainty $u(m_{ij})$ and number of degrees of freedom $\nu(m_{ij})$ are known or may be estimated. Assuming that $u(t_i)$, $u(t_j)$, $u(f_i)$ and $u(f_j)$ are negligible, it can be shown that:

$$u^2(d_{i,j}) = u^2(m_i) + u^2(m_j) - 2u^2(m_{ij}) + u^2(a_1) \cdot (t_i - t_j)^2 + u^2(a_2) \cdot \left(\frac{f_i - f_j}{1592 - 1000} \right)^2 \quad (8)$$

and

$$\nu(d_{i,j}) = \frac{u^4(d_{i,j})}{\frac{u^4(m_i)}{\nu(m_i)} + \frac{u^4(m_j)}{\nu(m_j)} - \frac{2u^4(m_{ij})}{\nu(m_{ij})} + \frac{u^4(a_1) \cdot (t_i - t_j)^4}{\nu(a_1)} + \frac{u^4(a_2) \cdot \left(\frac{f_i - f_j}{1592 - 1000} \right)^4}{\nu(a_2)}} \quad (9)$$

The expanded uncertainty is calculated as $U(d_{i,j}) = k_{i,j} \cdot u(d_{i,j})$ where $k_{i,j}$ is chosen to give 95% coverage based on $\nu(d_{i,j})$.

For further details of the calculation of the pair-wise degrees of equivalence refer to Appendix E.3.

6.5 Proposal for linking to CCEM-K4 key comparison and degrees of equivalence

We propose that the results of APMP.EM-K4.1 be linked to CCEM-K4 using a method similar to that used to link EUROMET.EM-K4 to CCEM-K4 (see Delahaye and Witt [3]).

6.5.1 Method of calculation of linking correction

The following notation is used:

$D_{i_{LINK}}$: result from CCEM-K4 for a linking laboratory

$d_{i_{LINK}}$: result from APMP.EM-K4.1 for a linking laboratory

d_i : result from APMP.EM-K4.1 for a laboratory participating in APMP.EM-K4.1 only

D_i : best estimate of result from laboratory i had it participated in CCEM-K4, estimated as

$$D_i = d_i + \Delta \quad (10)$$

Measurements from the linking laboratories provide estimates $\Delta_{i_{LINK}} = D_{i_{LINK}} - d_{i_{LINK}}$ for the correction Δ . The correction Δ is then calculated as the weighted mean of the linking laboratories estimates, that is:

$$\Delta = \sum_{i_{LINK}} w_{i_{LINK}} \Delta_{i_{LINK}} \quad (11)$$

where $w_{i_{LINK}} = \frac{s^2(\Delta)}{s^2(\Delta_{i_{LINK}})}$ and $s^2(\Delta) = \frac{1}{\sum_{i_{LINK}} \left(\frac{1}{s^2(\Delta_{i_{LINK}})} \right)}$. (11a)

The uncertainty, $s(\Delta_{i_{LINK}})$, associated with $\Delta_{i_{LINK}}$ is calculated as in [3] by the root-sum-square of the transfer uncertainty in the CCEM comparison, $u_T = 0.02 \mu\text{F/F}$, the transfer uncertainty in the APMP comparison, $u(p_i) \approx 0.03 \mu\text{F/F}$, and the uncertainty $r_{i_{LINK}}$ associated with the imperfect reproducibility of the results of laboratory i_{LINK} in the time period spanning its two measurements (counted twice).

6.5.2 Information from linking laboratories

The linking laboratories are NMIA, NIM and VNIIM. No significant changes to the method of measurement used in CCEM-K4 and APMP.EM-K4.1 were made by NMIA or by NIM. VNIIM, however, made significant changes between its 1997 measurements for CCEM-K4 and its 2005 measurements for APMP.EM-K4.1. These changes are summarised in Table 6-3 below.

Feature of measurement method changed	1997 measurements: CCEM-K4	2005 measurements: APMP.EM-K4.1
Measurement frequency	1592 Hz	1000 Hz
Nominal measurement temperature	25.0 °C	20.0 °C
Composition of group standard	Six fused-silica dielectric capacitors	Two of the fused-silica capacitors exchanged for air dielectric capacitors.
Temperature regulation and measurement	Guildline Oil bath, calibrated thermistor	Oil bath for working standards, Pt resistor
Transformer Bridge (TB)	Self-calibrated TB-comparator TMK	TB for measurement of working standards
Drift	-	Eight year drift
Capacitance Unit correction	-	Reduced by 0.20 $\mu\text{F/F}$ in March 2003
$r_{i_{LINK}}$	0.06 $\mu\text{F/F}$	0.08 $\mu\text{F/F}$

Table 6-3 Summary of changes to the method of measurement used in CCEM-K4 and APMP.EM-K4.1 by VNIIM.

Note that the uncertainty $r_{i_{LINK}}$ associated with the imperfect reproducibility of VNIIM's results does not include a time drift component, but it is expected that the contribution from this source will be small.

6.5.3 Calculated linking correction

The calculated linking correction is $\Delta = -0.004 \mu\text{F/F}$, with a standard deviation of $0.017 \mu\text{F/F}$. Table 6-4 lists the values of the quantities used in the calculation.

The data was tested using the consistency checks described in [3]. The Birge ratio is $R_B = 1.58$ with an uncertainty $u(R_B) = 0.26$ suggesting that the consistency between the variations between linking laboratories, and the uncertainties estimated by those laboratories, may not be adequate. However,

performing the chi-squared test gives the values $\chi^2_{obs} = 4.96$ and $\chi^2(2, 0.05) = 5.99$. Since $\chi^2(2, 0.05) > \chi^2_{obs}$ it can be concluded that there is no significant difference between the observed variance and the variance deduced using the laboratories' reproducibility estimates at the 95% confidence level.

Linking laboratory	D_{iLINK} ($\mu\text{F/F}$)	d_{iLINK} ($\mu\text{F/F}$)	Δ_{iLINK} ($\mu\text{F/F}$)	u_T ($\mu\text{F/F}$)	$u(p_i)$ ($\mu\text{F/F}$)	r_{iLINK} ($\mu\text{F/F}$)	$s(\Delta_{iLINK})$ ($\mu\text{F/F}$)	W_{iLINK}
NMIA	0.035	0.005	0.030	0.020	0.029	0.005	0.036	0.47
VNIIM	-0.118	0.003	-0.121	0.020	0.031	0.071	0.107	0.05
NIM	-0.040	-0.016	-0.024	0.020	0.028	0.0074	0.036	0.47

Table 6-4 CCEM-K4 and APMP.EM-K4.1 comparison results and standard uncertainties for linking laboratories.

Note that D_{iLINK} for VNIIM is taken as the CCEM-K4 result adjusted by the 2003 VNIIM Capacitance Unit correction.

6.5.4 Degrees of equivalence with respect to CCEM-K4 key comparison reference value

The best estimate of the result from laboratory i had it participated in CCEM-K4 is calculated using (10). The standard uncertainty and number of degrees of freedom for the degrees of equivalence are calculated as:

$$\begin{aligned}
 u^2(D_i) &= u^2(d_i) + u^2(\Delta) \\
 &= u^2(d_i) + s^2(\Delta) + u^2(m_{ref}) \quad (12) \\
 \nu(D_i) &= \frac{u^4(D_i)}{\frac{u^4(d_i)}{\nu(d_i)} + \frac{s^4(\Delta)}{2}}
 \end{aligned}$$

where $u(m_{ref}) = 0.017 \mu\text{F/F}$ is the uncertainty in m_{ref} , the CCEM-K4 Key Comparison Reference Value, and $\nu(m_{ref})$ is assumed to be infinite. The expanded uncertainty is then $U(D_i) = k_{D_i} \cdot u(D_i)$ where k_{D_i} is chosen to give 95 % coverage based on $\nu(D_i)$. The calculated degrees of equivalence with respect to CCEM-K4 key comparison reference value are tabulated in Table 6-5.

Participant	D_i μF/F	$U(D_i)$ μF/F
CMS	0.154	0.309
KIM-LIPI	-0.268	15.072
KRISS	-0.142	0.237
NIM	-	-
NIMT*	1.125	2.745
NMIA	-	-
NMIJ/AIST	0.124	0.254
NMISA	-0.048	0.240
NPLI	-1.060	0.752
SCL*	-3.342	7.860
SIRIM*	0.543	1.740
A*STAR	0.066	0.945
VNIIM*	-	-

Table 6-5 Proposed degrees of equivalence of the participating institutes relative to the CCEM key comparison reference value.

*Measurements made at a frequency of 1000 Hz (all other measurements at 1592 Hz). Values for linking laboratories are not shown.

6.5.5 Proposal for calculation of pair-wise degrees of equivalence D_{ij}

Category 1: Where laboratories i and j participated in one or both of comparisons CCEM-K4 or EUROMET.EM-K4, existing degrees of equivalence will stand, although there may be reason to consider re-evaluating pair-wise degrees of equivalence for NMISA.

Category 2: Where laboratory i participated only in APMP.EM-K4.1 and laboratory j participated in APMP.EM-K4.1, the pair-wise degrees of equivalence are those calculated in Section 6.4.2, that is

$$D_{i,j} = d_{i,j} \text{ and } U(D_{i,j}) = U(d_{i,j}). \quad (13)$$

Note that laboratory j may also have participated in CCEM-K4 and/or EUROMET.EM-K4.

Category 3: Where laboratory i participated only in APMP.EM-K4.1 and laboratory j participated in CCEM-K4 or EUROMET.EM-K4 but not in APMP.EM-K4.1, then

$$D_{i,j} = D_i - D_j, \quad (14)$$

$$u^2(D_{i,j}) = u^2(D_i) + u^2(D_j) - 2u^2(m_{ref}) - 2u_r^2 \quad (15)$$

and

$$v(D_{i,j}) = \frac{u^4(D_{i,j})}{\frac{u^4(D_i)}{v(D_i)} + \frac{u^4(D_j)}{v(D_j)} - \frac{2u^4(m_{ref})}{v(m_{ref})} - \frac{2u_r^4}{v_r}}. \quad (16)$$

where u_r is the standard uncertainty associated with a common reference standard (relevant only if laboratory i derives its traceability from laboratory j , or if laboratory i and laboratory j both derive

their traceability from a third laboratory) and ν_r is the number of degrees of freedom. The expanded uncertainty is calculated as $U(D_{i,j}) = k_{D_{i,j}} \cdot u(D_{i,j})$ where $k_{D_{i,j}}$ is chosen to give 95% coverage based on $\nu(D_{i,j})$.

7 Withdrawals or changes of results

The Measurement Standards Laboratory, Industrial Research Limited, New Zealand were unable to measure the capacitance standards due to unexpected circumstances and withdrew from the comparison before their scheduled measurements.

8 Requests for follow up bilateral comparisons

MSL, New Zealand and NPL, India have indicated that they may wish to participate in bilateral comparisons in the future.

9 Summary and conclusions

A key comparison of capacitance at 10 pF has been conducted between participating APMP member laboratories. In general there is good agreement between participating laboratories in the region for this quantity. It is expected that this comparison will be able to provide support for participants' entries in Appendix C of the Mutual Recognition Arrangement.

10 Appendices

Appendix A: Degrees of equivalence

Proposed degrees of equivalence for participants of APMP.EM-K4.1 with participants in CCEM-K4, EUROMET.EM-K4 and APMP.EM-K4.1 are given in Table A - 1. Degrees of equivalence determined in previous comparisons are not shown.

Degrees of equivalence, D_i , with respect to the CCEM-K4 key comparison reference value are plotted in Figure A - 1 for participants in CCEM-K4, EUROMET.EM-K4 and APMP.EM-K4.1.

Lab i ↓	Lab j →																					
	D_i / 10 ⁻⁶	$U(D_i)$	CMS		KIM-LIPI		KRISS		NIMT		NMI/AIST		NMISA		NPLI		SCL		SIRIM		A*STAR	
			D_{ij} / 10 ⁻⁶	$U(D_{ij})$	D_{ij} / 10 ⁻⁶	$U(D_{ij})$	D_{ij} / 10 ⁻⁶	$U(D_{ij})$	D_{ij} / 10 ⁻⁶	$U(D_{ij})$	D_{ij} / 10 ⁻⁶	$U(D_{ij})$	D_{ij} / 10 ⁻⁶	$U(D_{ij})$	D_{ij} / 10 ⁻⁶	$U(D_{ij})$	D_{ij} / 10 ⁻⁶	$U(D_{ij})$	D_{ij} / 10 ⁻⁶	$U(D_{ij})$	D_{ij} / 10 ⁻⁶	$U(D_{ij})$
BIPM	-0.018	0.105	-0.172	0.323	0.250	15.073	0.124	0.249	-1.143	2.746	-0.142	0.270	0.030	0.238	1.042	0.757	3.324	7.860	-0.561	1.740	-0.084	0.949
BNM-LCIE	-0.216	0.092	-0.370	0.319	0.052	15.072	-0.074	0.248	-1.341	2.746	-0.340	0.266	-0.168	0.252	0.844	0.756	3.126	7.860	-0.759	1.742	-0.282	0.948
NMIA	0.035	0.069	-0.153	0.313	0.269	15.072	0.144	0.226	-1.124	2.745	-0.122	0.259	0.049	0.247	1.062	0.754	3.344	7.860	-0.541	1.741	-0.065	0.946
MSL	-0.026	0.124	-0.180	0.329	0.242	15.073	0.116	0.260	-1.151	2.747	-0.150	0.278	0.022	0.265	1.034	0.760	3.316	7.861	-0.569	1.743	-0.092	0.952
NIM	-0.040	0.261	-0.174	0.373	0.248	15.074	0.123	0.310	-1.145	2.752	-0.143	0.328	0.028	0.312	1.041	0.778	3.323	7.862	-0.562	1.751	-0.086	0.967
NIST	-0.003	0.029	-0.157	0.307	0.265	15.072	0.139	0.234	-1.128	2.744	-0.127	0.252	0.045	0.237	1.057	0.751	3.339	7.860	-0.546	1.740	-0.069	0.944
NMI-VSL	-0.772	1.200	-0.926	1.237	-0.504	15.118	-0.630	1.219	-1.897	2.984	-0.896	1.225	-0.724	1.222	0.288	1.409	2.570	7.947	-1.315	2.100	-0.838	1.519
NPL	0.198	0.116	0.044	0.326	0.466	15.073	0.340	0.256	-0.927	2.747	0.074	0.275	0.246	0.262	1.258	0.759	3.540	7.860	-0.345	1.743	0.132	0.944
NRC	0.037	0.324	-0.117	0.443	0.305	15.076	0.179	0.391	-1.088	2.762	-0.087	0.407	0.085	0.398	1.097	0.815	3.379	7.866	-0.506	1.768	-0.029	0.996
PTB	-0.004	0.092	-0.158	0.319	0.264	15.072	0.138	0.248	-1.129	2.744	-0.128	0.266	0.044	0.252	1.056	0.756	3.338	7.860	-0.547	1.742	-0.070	0.948
VNIM	-0.318	0.401	-0.155	0.471	0.267	15.076	0.142	0.399	-1.126	2.767	-0.124	0.439	0.047	0.432	1.060	0.831	3.342	7.867	-0.543	1.774	-0.067	1.008
BEV	0.407	1.404	0.253	1.435	0.675	15.135	0.549	1.420	-0.718	3.068	0.283	1.425	0.455	1.423	1.467	1.586	3.749	7.979	-0.136	2.220	0.341	1.684
CEM	-0.013	3.002	-0.167	3.017	0.255	15.357	0.129	3.010	-1.138	4.040	-0.137	3.012	0.035	3.011	1.047	3.090	3.329	8.392	-0.556	3.451	-0.079	3.141
CMI	-0.243	0.412	-0.397	0.510	0.025	15.078	-0.101	0.466	-1.368	2.773	-0.367	0.480	-0.195	0.472	0.817	0.853	3.099	7.870	-0.786	1.785	-0.309	1.027
CSIR-NML	0.327	2.502	0.173	2.520	0.595	15.271	0.469	2.511	-0.798	3.689	0.203	2.514	0.375	2.513	1.387	2.608	3.669	8.233	-0.216	3.028	0.261	2.668
GUM	-0.393	0.806	-0.547	0.860	-0.125	15.093	-0.251	0.834	-1.518	2.853	-0.517	0.842	-0.345	0.838	0.667	1.095	2.949	7.899	-0.936	1.909	-0.459	1.235
IEN	0.317	0.806	0.163	0.860	0.585	15.093	0.459	0.834	-0.808	2.855	0.193	0.842	0.365	0.838	1.377	1.095	3.659	7.899	-0.226	1.909	0.251	1.235
METAS	-0.193	62.000	-0.347	62.001	0.075	63.733	-0.051	62.000	-1.318	62.057	-0.317	62.000	-0.145	62.000	0.867	62.004	3.149	62.473	-0.736	62.023	-0.259	62.007
MIKES/VT	-0.913	1.504	-1.067	1.533	-0.645	15.144	-0.771	1.519	-2.038	3.114	-1.037	1.524	-0.865	1.521	0.147	1.675	2.429	7.996	-1.456	2.283	-0.979	1.767
SP	-0.593	1.802	-0.747	1.827	-0.325	15.175	-0.451	1.814	-1.718	3.264	-0.717	1.818	-0.545	1.814	0.467	1.946	2.749	8.055	-1.136	2.485	-0.659	2.027
UME	0.327	1.602	0.173	1.630	0.595	15.154	0.469	1.616	-0.798	3.160	0.203	1.620	0.375	1.618	1.387	1.763	3.669	8.014	-0.216	2.348	0.261	1.852
CMS	0.154	0.309		0.422	15.075		0.297	0.362	-0.971	2.761	0.031	0.257	0.202	0.270	1.215	0.811	3.497	7.861	-0.388	1.744	0.088	0.946
KIM-LIPI	-0.268	15.072	-0.422	15.075			-0.125	15.074	-1.393	15.316	-0.392	15.074	-0.220	15.074	0.793	15.091	3.075	16.991	-0.811	15.171	-0.334	15.102
KRISS	-0.142	0.237	-0.297	0.362	0.125	15.074			-1.268	2.753	-0.266	0.319	-0.095	0.321	0.918	0.781	3.200	7.862	-0.685	1.752	-0.209	0.963
NIMT	1.125	2.745	0.971	2.761	1.393	15.316	1.268	2.753			1.002	2.755	1.173	2.752	2.186	2.841	4.468	8.317	0.583	3.238	1.059	2.900
NMI/AIST	0.124	0.254	-0.031	0.257	0.392	15.074	0.266	0.319	-1.002	2.755			0.171	0.204	1.184	0.791	3.466	7.859	-0.419	1.735	0.057	0.930
NML,CSIR	-0.048	0.240	-0.202	0.270	0.220	15.074	0.095	0.321	-1.173	2.752	-0.171	0.204			1.013	0.778	3.295	7.858	-0.590	1.727	-0.114	0.932
NPLI	-1.060	0.752	-1.215	0.811	-0.793	15.091	-0.918	0.781	-2.186	2.841	-1.184	0.791	-1.013	0.778			2.282	7.894	-1.603	1.889	-1.127	1.206
SCL	-3.342	7.860	-3.497	7.861	-3.075	16.991	-3.200	7.862	-4.468	8.317	-3.466	7.859	-3.295	7.858	-2.282	7.894			-3.885	8.041	-3.409	7.910
SIRIM	0.543	1.740	0.388	1.744	0.811	15.171	0.685	1.752	-0.583	3.238	0.419	1.735	0.590	1.727	1.603	1.889	3.885	8.041			0.476	1.956
SPRING	0.066	0.945	-0.088	0.946	0.334	15.102	0.209	0.963	-1.059	2.900	-0.057	0.930	0.114	0.932	1.127	1.206	3.409	7.910	-0.476	1.956		

Table A - 1 Proposed degrees of equivalence for participants of APMP.EM-K4.1 with participants in CCEM-K4 (red), EUROMET.EM-K4 (blue) and APMP.EM-K4.1 (green). Results shaded in pale yellow are calculated as Category 2 and those in yellow as Category 3 (see Section 6.5.5 for explanation of categories).

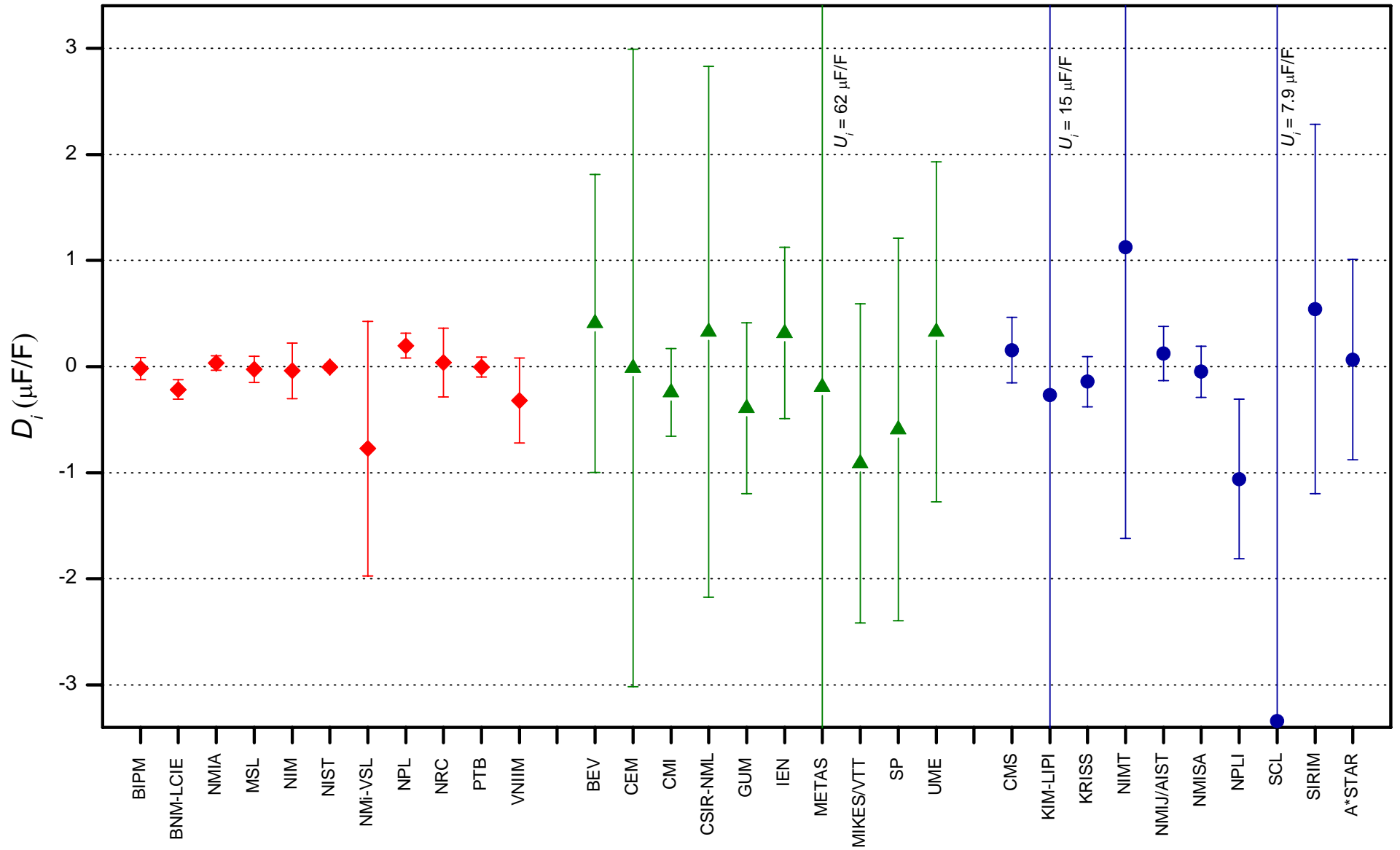

Figure A - 1 Degrees of equivalence, D_i , with respect to the CCEM-K4 key comparison reference value, for CCEM-K4 (red diamonds), EUROMET.EM-K4 (green triangles) and APMP.EM-K4.1 (blue circles). Uncertainty bars represent the expanded uncertainty, U_i .

Appendix B: Methods of measurement

Details of the method of measurement and traceability to the SI, as reported by participants, are reproduced below. Note that information relating to the supplementary comparison APMP.EM-S7 conducted at the same time as APMP.EM-K4.1 is included in some cases as the protocol did not require participants to describe their method of measurement separately.

B.1 Method of measurement: CMS, Taiwan

The comparison artefacts, 10 pF and 100 pF capacitors, are compared to 1000 pF reference standards individually by the 10:1 four terminal-pair (4TP) coaxial transformer bridge. The 1000 pF reference standard is GR1404A air standard capacitor which is traceable to DC quantum Hall resistance of CMS through ac resistance standards by using the quadrature bridge.

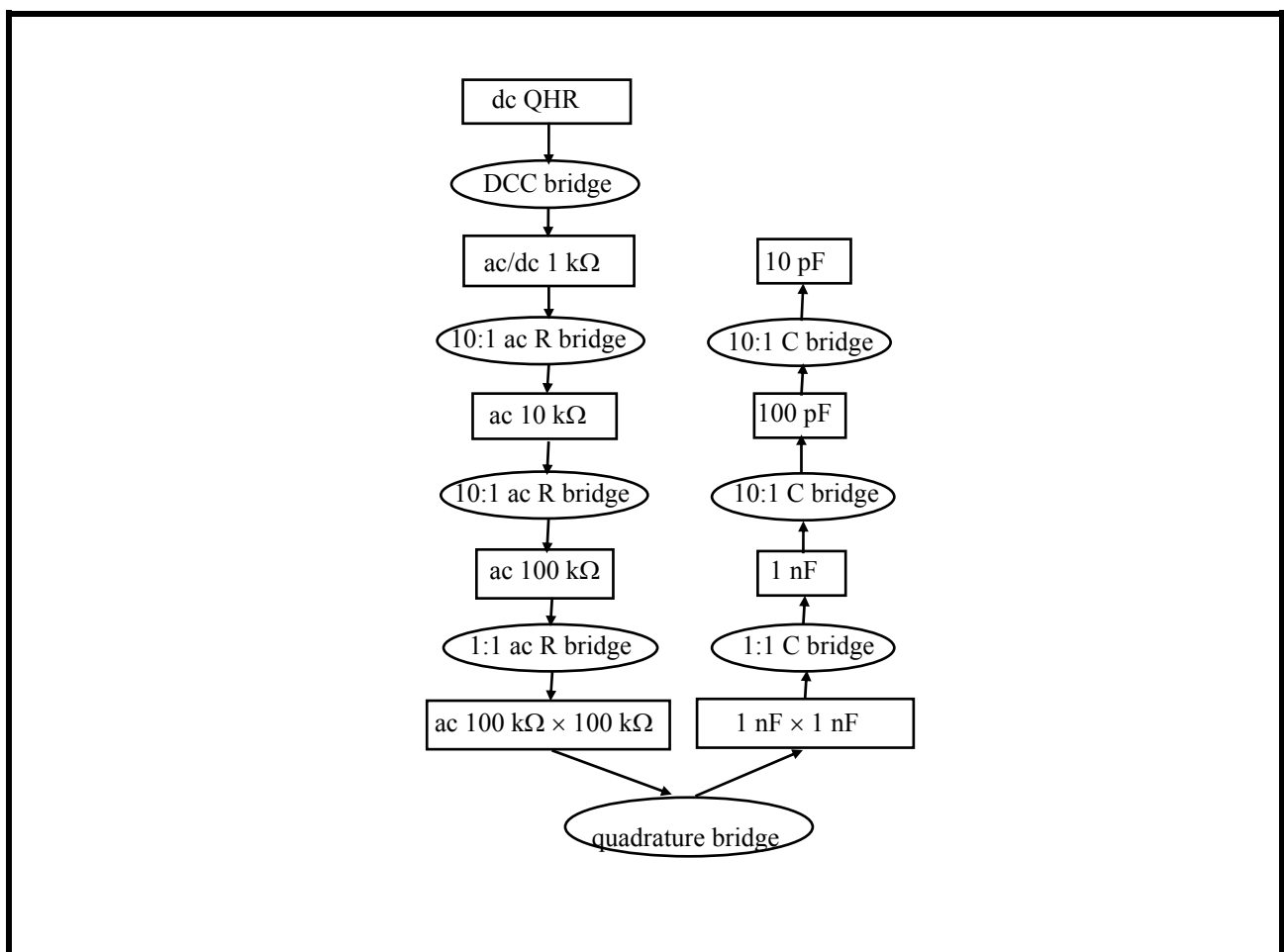

Figure A - 2 CMS Traceability to the SI.

B.2 Method of measurement: KIM-LIPI, Indonesia

Facilities:

- Standard Capacitor GR-1404B (100pF): as reference.
- Capacitance Measurement System GR-1621: as comparator.

-Thermo-Hygrometer Corona GL-89.

Methodology:

-Artefact (10pF & 100pF) was compared to reference capacitor (100pF), and used Capacitance Measurement System GR-1621 with ratio 1:1 and 1:10.

-Measurement or comparison was repeated 10 times.

-Capacitor or room temperature was measured during artefact measurements.

B.3 Method of measurement: KRISS, Korea

For the key and supplementary comparisons, a 10:1 ratio transformer bridge (see Figure A - 3) developed by a joint work between NMIA and KRISS was used.

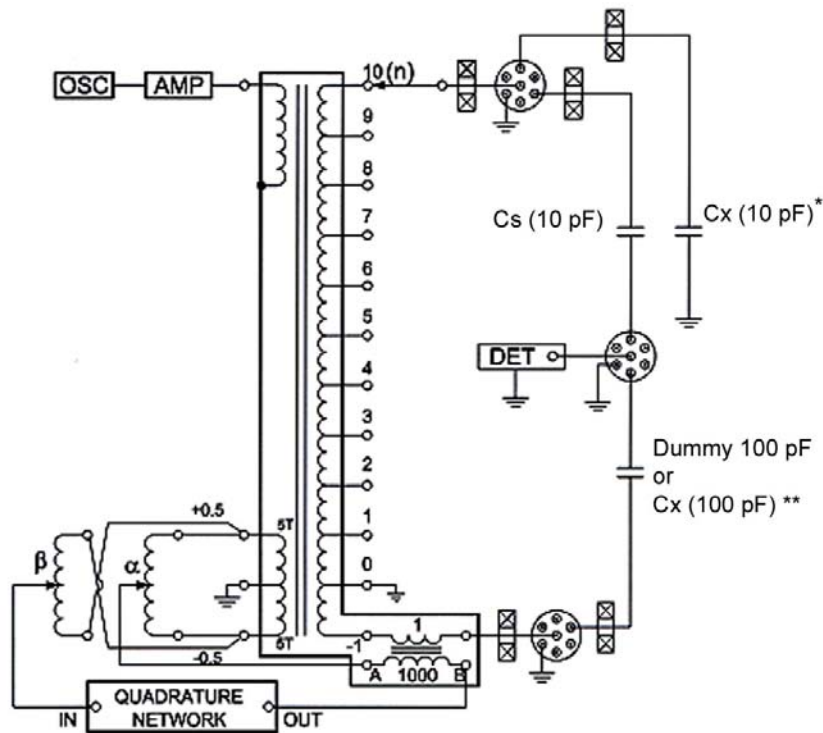

Figure A - 3 KRISS 10:1 ratio transformer bridge.

For the 10 pF (*) capacitor, it was measured by a substitution method between a 10 pF Zerodur standard capacitor and the 10 pF A/H capacitor, $C_x(10 \text{ pF})^*$. And for 100 pF A/H capacitor (**), it was measured by 10:1 comparison method after disconnecting the $C_x(10 \text{ pF})^*$.

As a calculable cross capacitor and toroidal cross capacitors have been developed at KRISS and are under analytical evaluation, the KRISS national standard of capacitance has been maintained using a 10 pF Zerodur capacitor developed in 1985 by a joint work between NMIA and KRISS. Since 1987, some of bilateral comparisons between NMIA and KRISS were carried out. In 1996 the value of standard was corrected by an inter-comparison among NMIA, KRISS and VNIIM. Continuously, this standard value has been traced through a comparison between BIPM and KRISS using a KLR standard capacitor developed at KRISS. After that, since 2002, not only a Zerodur capacitor but also a group of KLR capacitors are maintained as capacitance standard of KRISS.

Recently a bilateral comparison between KRISS and CENAM was carried out by using A/H capacitors, and then the results have been re-confirmed through calibration at BIPM for the same capacitors.

The value for the KRISS reference standard is derived from an extrapolation of a quadratic least squares fit to seven data points based on the following measurements:

- [1] On May 1987, the 10 pF Zerodur capacitor (s/n S-65146), maintenance standard, was compared with another 10 pF Zerodur capacitor (s/n S-65145) calibrated by NML CSIRO and hand-carried to the KRISS by Greig Small (uncertainty was evaluated to be 0.5 ppm).
- [2] On November 1991, the same Zerodur capacitor (s/n S-65146) was hand-carried by Raeduk LEE to NMIA, and compared again with uncertainty 0.5 ppm.
- [3] On April 1995, a bilateral comparison between KRISS, NMIA and VNIIM was carried out by using two 10 pF fused silica capacitors (KKC-1, #4 and #8) as a travelling standard (uncertainty was less than 0.1 ppm).
- [4] On July 1999, a bilateral comparison between KRISS and VNIIM participated to the CCEM KC was carried out again by using the same fused silica capacitor KKC-1, #8 (uncertainty was less than 0.1 ppm).
- [5] On June 2001, a 10 pF KLR capacitor (s/n 12/12) developed by Raeduk LEE was hand-carried to BIPM, and re-confirmed the KRISS standard value with uncertainty less than 0.1 ppm.
- [6] On July 2003, a bilateral comparison between KRISS, CENAM was carried out by using A/H 11A, then the same A/H capacitor was measured at BIPM (uncertainty was less than 0.1 ppm).
- [7] On May 2005, a bilateral comparison between KRISS and NIST was carried out by using the same KLR capacitor, s/n 12/12 (uncertainty was less than 0.1 ppm).

B.4 Method of measurement: NIM, China

The national capacitance standard was established in NIM in 1982. The essential part of this standard is a calculable capacitor of Thompson-Lampard type. The nominal value of the calculable capacitor is 0.5 pF and the uncertainty is 1×10^{-7} . The main source of the uncertainty is from the axial length determination of the capacitor.

A transformer bridge is prepared for the capacitance comparison. The ratio of the bridge is 1:1, 1:2, 1:5 and 1:10. The uncertainty of the comparison is 3×10^{-9} .

The working capacitance standard is a set of 10 pF and 100 pF fused silica capacitors. The values of the working capacitance standard are determined by the calculable capacitor periodically. The uncertainty of the value of the working standard is 0.11 ppm. The APMP Key comparison of capacitance at 10 pF and the APMP supplementary comparison of capacitance at 100 pF are completed by direct comparison of the travelling standard to the working standard of capacitance.

B.5 Method of measurement: NIMT, Thailand

The fused silica capacitance standard, Capacitor A (B), was measured by using null method with the capacitance bridge, GR 1620 and the NIMT reference standard capacitor GR1404 C

(GR1404 B). At balance, the value of the said capacitance is the value of the reference standard capacitor multiplied by the bridge ratio.

The measurement is traceable to the Physikalisch-Technische Bundesanstalt (PTB), Germany through PTB Certificate No. 2339 PTB 03, 2338 PTB 03 and 2337 PTB 03.

B.6 Method of measurement: NMI, Australia

The NMIA derives its capacitance standard from a Thompson-Lampard calculable capacitor [4-7] traceable to the SI via NMIA's length standard.

The Calculable Capacitor ($\frac{1}{6}$ pF) is used to measure three $\frac{1}{6}$ pF fixed capacitors by substitution on a transformer ratio bridge.

These three measured capacitors are then connected in parallel to constitute a reference capacitor of nominal value 0.5 pF, that is used on the NMIA 10:1 Transformer Ratio Bridge to measure 5 pF, then 50 pF, reference capacitors.

The measurement sequence linking the 50 pF reference capacitor to the Calculable Capacitor was performed at 1592 Hz within 10 days of each of the reported measurements. The history of the reference capacitor was used to interpolate (or in limited cases, extrapolate) its value, to obtain a value at the time of the reported measurements.

At the time of each independent measurement of the comparison artefact, the 50 pF reference capacitor (50I) is compared with another 50 pF capacitor (50P) to obtain a 100 pF working standard (50I + 50P). The known frequency coefficient of the reference capacitor 50I is used to calculate a value for the working standard for measurements at 1000 Hz.

The comparison artefact is compared with the 100 pF working standard on the same NMI 10:1 Transformer Ratio Bridge by direct comparison.

B.7 Method of measurement: NMIJ/AIST, Japan

The reference standards of capacitance are traceable to the QHR at NMIJ, the value of which is $R_{K-90}/2$ with a relative standard uncertainty of 1×10^{-7} to the SI.

By using the four terminal-pair resistance bridge, the two terminal-pair quadrature bridge, the two terminal-pair capacitance bridge and the ac/dc calculable resistor, the capacitance was derived from the Quantized Hall Resistance (QHR).

B.8 Method of measurement: NMISA, South Africa

The intercomparison artefacts, a 10 pF AH11A Fused Silica Standard and a 100 pF AH11A Fused Silica Standard were compared to standards of the same type and nominal value, as listed in Table A - 2, by direct substitution using an Andeen-Hagerling 2500 A Ultraprecision Capacitance Bridge, at 1 kHz. The voltages applied to the capacitor by this bridge are not specified, but are limited to about 15 V at 10 pF and 7,5 V at 100 pF. The capacitance was evaluated for a measuring voltage of 10 V by including the uncertainty due to the voltage coefficient of the capacitors. The environmental temperature of the laboratory was 24 °C during the comparison measurements. The capacitance was evaluated for a nominal temperature of 20 °C, by including the uncertainty due to the temperature coefficients of the capacitors. For the evaluations at 100 V, corrections for the values of the capacitors cannot be made, since the actual voltage coefficients of the capacitors are

not known. Therefore we included only an extra uncertainty component based on the manufacturer’s specifications for the voltage coefficients of the capacitors.

Description	Make & Model	Serial / ID Number
10 pF Fused Silica Standard	Andeen-Hagerling, AH11A	01286
100 pF Fused Silica Standard	Andeen-Hagerling, AH11A	01287
Ultraprecision Capacitance Bridge	Andeen-Hagerling, AH 2500 A	000 640
Low Noise Coaxial Cable	Andeen-Hagerling, DCOAX	CRN-0241/1

Table A - 2 NMISA reference standards and equipment used.

B.9 Method of measurement: NPL, India

The values of two 10 pF capacitors (one GenRad GR1404-C and one Andeen-Hagerling AH-11A) were derived from the calculable capacitor. Two 100 pF capacitors were measured against these two 10 pF capacitors using a 10:1 bridge and a direct comparison method.

The 10 pF comparison artefact was compared against the two 10 pF capacitors in turn using the 10:1 bridge and a 1:1 substitution method.

B.10 Method of measurement: SCL, Hong Kong

The capacitance of the test capacitors was determined at 1 kHz by substitution method. The laboratory’s reference standard capacitors were first measured using an Andeen-Hagerling capacitance bridge model AH 2500A. The test capacitors were then measured using the same bridge. The difference between the two readings was used, together with the known values of the reference standard capacitors, to calculate the values of the test capacitors.

The two reference standard capacitors (10 pF and 100 pF) were calibrated by NPL, UK for traceability to SI.

B.11 Method of measurement: SIRIM, Malaysia

The 10 pF capacitor was measured by comparison against the 10 pF reference capacitor maintained by the National Metrology Laboratory, Malaysia, at a frequency of 1000 Hz and a voltage of 100 V using the GR 1615A capacitance bridge. See Figure A - 4.

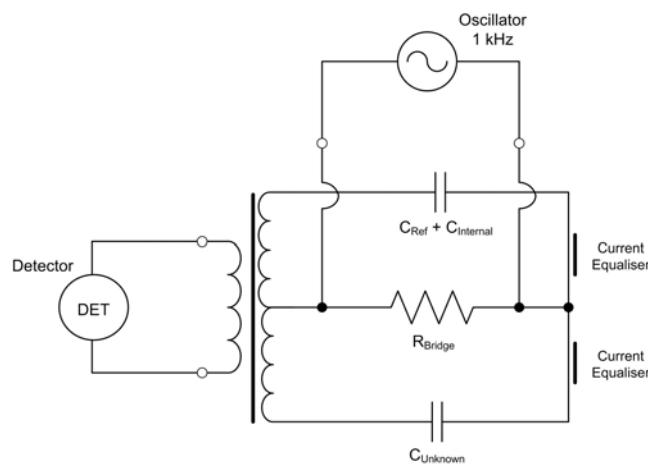

Figure A - 4: SIRIM GR 1615A Bridge configuration for measurement of 10 pF at 100 V.

B.12 Method of measurement: A*STAR, Singapore

A GenRad (GR) 1621A Precision Capacitance Bridge was used for the measurements of 10 pF and 100 pF travelling capacitance standards at 1 kHz and 1.592 kHz. The GR bridge was used with an external thermostatted fused silica dielectric capacitance standard as a reference capacitor. For the comparison, a substitution method of measurement was used to compare the travelling standards against similar capacitance reference standards, using the GR's external reference capacitor as a 'dummy' standard. The capacitance reference standards have been calibrated with traceability to the unit of capacitance maintained by groups of capacitance standards at 10 pF and 100 pF.

B.13 Method of measurement: VNIIM, Russia

The TO-1 transformer bridge which is a part of the secondary standard of capacitance was used to measure 10 and 100 pF capacitors (simplified circuit diagram is shown in Figure A - 5). Ratio windings of this bridge are executed as copper straps located side by side (the design is similar to that described in [8]) so that the output impedance does not exceed 0.030Ω at 1 kHz. The bridge can be balanced by adjustment of two six-decade IVDs whose outputs are connected in series with the quadrature circuit and the injection transformer.

The 10 pF AH capacitor is measured by means of substitution method with use of 10 pF capacitors from the group standard that maintains the national unit of capacitance.

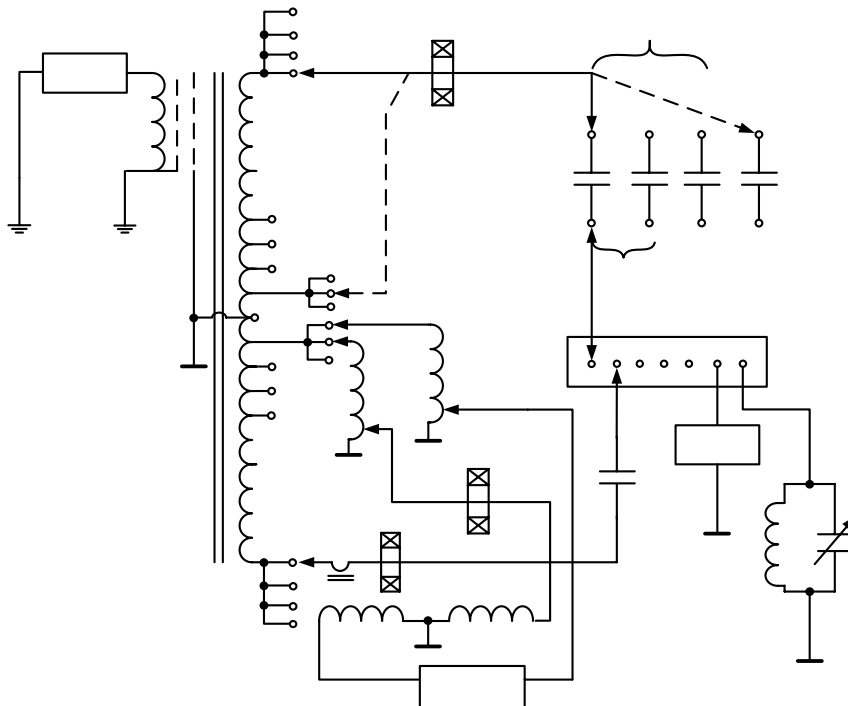

Figure A - 5: VNIIM TO-1 transformer bridge.

Traceability to the SI:

Capacitance unit is realized at 1 kHz by means of the vertical TL calculable cross capacitor with 0.2 pF nominal capacitance. In [9] it is fixed that the standard deviation (S_0) does not exceed $0.2 \mu\text{F/F}$, and the estimation of limit of a relative systematic error (θ_0) does not exceed $0.5 \mu\text{F/F}$

when capacitance unit is realized at 1 kHz. Capacitance unit is maintained by the 10 pF group standard that consists of fused silica capacitors of various types – with fused silica dielectric (three different models) and with gas dielectric (KLR type). Capacitors of the group standard are placed in the oil bath at 20 °C or are kept in their own temperature-regulated enclosures.

Appendix C: Uncertainty statements

C.1 Uncertainty statement: CMS, Taiwan

APMP.EM-K4.1 (10 pF)								
Quantity	Estimate	Unit	Standard uncertainty	Unit	Effective DOF	Sensitivity coefficient	Unit	Contribution to rel. std. unc. ($\mu\text{F}/\text{F}$)
1. Realisation of SI farad: reference standard 100 pF reference standard traceable to DC quantum Hall resistance (1)			0.146	$\mu\text{F}/\text{F}$	∞	1		0.146
2. Measurement of comparison artefact Repeatability			0.028	$\mu\text{F}/\text{F}$	5	1		0.028
Temperature correction for 100 pF reference standard			0.003	$\mu\text{F}/\text{F}$	∞	1		0.003
Drift rate of 100 pF reference standard during measurement			0	$\mu\text{F}/\text{F}$	∞	1		0
Ratio transformer			0.02	$\mu\text{F}/\text{F}$	∞	1		0.02
Bridge network			0.01	$\mu\text{F}/\text{F}$	∞	1		0.01
Final Values:	-0.230	$\mu\text{F}/\text{F}$			4169			0.150

Notes:

- The von Klitzing constant of $R_{K-90} = 25812.807 \Omega$ with a relative standard uncertainty $0.1 \mu\Omega/\Omega$ was used.

C.2 Uncertainty statement: KIM-LIPI, Indonesia

APMP.EM-K4.1 (10 pF)								
Quantity	Estimate	Unit	Standard uncertainty	Unit	Effective DOF	Sensitivity coefficient	Unit	Contribution to rel. std. unc. ($\mu\text{F}/\text{F}$)
Measurement of comparison artefact Mean of n independent measurements	-0.50	$\mu\text{F}/\text{F}$	0.104	$\mu\text{F}/\text{F}$	9	1		0.104
Reference Capacitance			0.612	$\mu\text{F}/\text{F}$	>120	1		0.612
Capacitance Drift			0.577	$\mu\text{F}/\text{F}$	∞	1		0.577
Bridge Accuracy			7.506	$\mu\text{F}/\text{F}$	∞	1		7.506
Bridge Accuracy (freq)	1592	Hz	0.824	$\mu\text{F}/\text{F}$	∞	1		0.824
Bridge Resolution			0.003	$\mu\text{F}/\text{F}$	∞	1		0.003
Lead Correction			0.548	$\mu\text{F}/\text{F}$	∞	1		0.548
Reference Temperature	23	$^{\circ}\text{C}$	0.577	$^{\circ}\text{C}$	∞	1.88	$\mu\text{F}/\text{F}/\text{K}$	1.085
Artefact Temperature	23	$^{\circ}\text{C}$	1.732	$^{\circ}\text{C}$	∞	0.01	$\mu\text{F}/\text{F}/\text{K}$	0.017
Measurement Voltage	100	V	4.388	V	∞	0.003	$\mu\text{F}/\text{F}/\text{V}$	0.013
Measurement Frequency	1592	Hz						
Power Line	220	V						
Final Values:	-0.50	$\mu\text{F}/\text{F}$			>120			7.69

C.3 Uncertainty statement: KRISS, Korea

Full uncertainty statements are only given below for measurements at 1592 Hz. Where uncertainty components vary for measurements at 1000 Hz, this is indicated in the footnotes.

APMP.EM-K4.1 (10 pF)								
Quantity	Estimate	Unit	Standard uncertainty	Unit	Effective degrees of freedom	Sensitivity coefficient	Unit	Contribution to the relative standard uncertainty ($\mu\text{F}/\text{F}$)
1. Realisation of SI farad: reference standard								
Reference standard (1)	10	pF	0.10	$\mu\text{F}/\text{F}$	13	1		0.10
2. Working standard								
Zerodur capacitor (2)	(10)	pF	(0.10)	$\mu\text{F}/\text{F}$				
3. Measurement of comparison artefact								
Mean of 12 independent measurements (5)	-0.439	$\mu\text{F}/\text{F}$	0.003	$\mu\text{F}/\text{F}$	11	1		0.003
Bridge resolution	0	$\mu\text{F}/\text{F}$	0.029	$\mu\text{F}/\text{F}$	13	1		0.029
Lead correction (3),(5)	-0.067	$\mu\text{F}/\text{F}$	0.014	$\mu\text{F}/\text{F}$	13	1		0.014
Temperature (19.4 \rightarrow 20.0 $^{\circ}\text{C}$) (4)	+0.006	$\mu\text{F}/\text{F}$	0.16	$^{\circ}\text{C}$	11	0.01	$\mu\text{F}/\text{F}/\text{K}$	0.002
Final Values:	-0.500	$\mu\text{F}/\text{F}$			15			0.105

Notes:

1. A Zerodur capacitor was used as a reference capacitor of KRISS.
2. The Zerodur capacitor was directly used as a working standard capacitor.
3. The leads for our own bridge were used.
4. Type A uncertainty only.
5. Uncertainty components vary slightly for measurements at 1000 Hz.

C.4 Uncertainty statement: NIM, China

Item X_i	Sort (A, B)	Uncertainty $u_i(X)$ ($\times 10^{-6}$)
Experimental standard uncertainty	A	0.0114 freedom degrees is 7
Uncertainty from working standard	B	0.11
Uncertainty from leads correction	B	0.002
Uncertainty from ambient temperature	B	0.002
Combined Standard Uncertainty		0.11

C.5 Uncertainty statement: NIMT, Thailand

Mathematical model :

$$C_x = [C_s(1 + T_k \Delta T)(1 + D_r \Delta t) \cdot M_x \cdot M] + C_d + \delta_{res} + \delta_{volt} + \delta_{temp_uuc}$$

Where:

C_x	=	Measured value of unknown capacitor
C_s	=	Capacitance of standard capacitor
$M_x \cdot M$	=	Capacitance bridge ratio
C_d	=	Difference value in between the unknown and the standard capacitor
T_k	=	Temperature coefficient of standard
ΔT	=	Difference in temperature between the calibrated temperature of standard and the ambient temperature
D_r	=	Secular drift of standard
Δt	=	Period of time since last calibration to present
δ_{res}	=	Unknown deviation due to resolution of the capacitance bridge
δ_{volt}	=	Unknown deviation due to measurement voltage
δ_{temp_uuc}	=	Unknown deviation due to ambient laboratory differing from 20 °C

Reference standard capacitors (C_s)

The calibration certificate for the reference standard gives a capacitance value of 10,000127 pF $\cdot (1 \pm 1 \cdot 10^{-6})$ (coverage factor $k=2.1$) at the specified reference temperature of 23,0 °C. The probability distribution is normal then the value of uncertainty taken into account of the uncertainty budget is $u(C_s) = 0,48 \cdot 10^{-6}$.

Temperature ($T_k, \Delta T$)

No correction is made for the temperature coefficient of reference standard. During measurement the reference standard must be kept in air bath which is temperature $(23,0 \pm 0,3 \text{ °C})$. The value of $T_k \cdot \Delta T$ is $5 \cdot 10^{-6} / \text{C}^\circ \cdot 0,3 \text{C}^\circ = 1,5 \cdot 10^{-6}$. The probability distribution is assumed to be rectangular and then the value of uncertainty taken into account of the uncertainty budget is $u(T_k \cdot \Delta T) = 1,5 \cdot 10^{-6} / \sqrt{3} = 0,87 \cdot 10^{-6}$.

Drift of the value of the standard ($D_r, \Delta t$)

The drift from the history of reference standard capacitor is $0,8 \cdot 10^{-6}$ within $0,7 \cdot 10^{-6}$. The probability distribution is normal then the value of uncertainty taken into account of the uncertainty budget is $u(D_r, \Delta t) = 0,7 \cdot 10^{-6}$.

Capacitance Bridge ratio ($M_x \cdot M$)

No correction is made for error due to the bridge transformer ratios. It is typically within $\pm 1 \cdot 10^{-6}$ estimated from specification for a ratio of 1. The probability distribution is assumed to be rectangular then the value of uncertainty taken into account of the uncertainty budget is $u(M_x \cdot M) = 1 \cdot 10^{-6} / \sqrt{3} = 0,58 \cdot 10^{-6}$.

Resolution of the capacitance readout (δ_{res})

No correction is made for rounding due to the resolution of the capacitance readout of the bridge. The last significant digit on the value being calibrated corresponds to $\pm 1 \cdot 10^{-6}$. The probability distribution is assumed to be rectangular then the value of uncertainty taken into account of the uncertainty budget is $u(\delta_{res}) = 1 \cdot 10^{-6} / \sqrt{3} = 0,58 \cdot 10^{-6}$.

Measurement voltage (δ_{volt})

The voltage coefficient of a UUC from the specification to be $0,003 \cdot 10^{-6} / \text{V}$. No correction is made for the measurement voltage. The applied voltage is $(100 \pm 1 \text{ V})$. The value of (δ_{volt}) is $0,003 \cdot 10^{-6} / \text{V}^\circ \cdot 1 \text{V} = 0,003 \cdot 10^{-6}$. The probability distribution is assumed to be rectangular and then the value of uncertainty taken into account of the uncertainty budget is $u(\delta_{volt}) = 0,003 \cdot 10^{-6} / \sqrt{3} = 0,0017 \cdot 10^{-6}$.

Ambient laboratory differing from 20 °C (δ_{temp_uuc})

The temperature coefficient of a UUC from the specification to be $0,01 \cdot 10^{-6} / \text{°C}$. No correction is made for the temperature coefficient. The ambient laboratory is $(23,0 \pm 2,0 \text{ °C})$. The maximum value of temperature coefficient is $0,01 \cdot 10^{-6} / \text{C}^\circ \cdot 5 \text{C}^\circ = 0,05 \cdot 10^{-6}$. The probability distribution is assumed to be rectangular and then the value of uncertainty taken into account of the uncertainty budget is $u(\delta_{temp_uuc}) = 0,05 \cdot 10^{-6} / \sqrt{3} = 0,03 \cdot 10^{-6}$.

Measurement (C_d)

The observations are made for the difference between the unknown capacitor and the reference standard from the capacitance bridge readout. The uncertainty due to repeatability, $u(C_d)$ of 5 measurements are calculated and assumed a normal distribution.

Capacitance 10 pF @ 1 kHz

Quantity	Estimate	Standard Uncertainty		Probability Distribution	Effective degree of freedom(ν_i)	Sensitivity Coefficient c_i	Uncertainty Contribution	
		$u(x_i)$					$u(y_i)$	
X_i	x_i	Relative	Absolute				Relative	Absolute
C_s	10,000 127 pF	$0,48 \cdot 10^{-6}$	-	Normal	18	1	$0,48 \cdot 10^{-6}$	-
$T_k \Delta T$	0	$0,87 \cdot 10^{-6}$	-	Rectangular	∞	1	$0,87 \cdot 10^{-6}$	-
$D \Delta t$	$+0,8 \cdot 10^{-6}$	$0,7 \cdot 10^{-6}$	-	Normal	14	1	$0,7 \cdot 10^{-6}$	-
$M_x \cdot M$	1	$0,58 \cdot 10^{-6}$	-	Rectangular	∞	1	$0,58 \cdot 10^{-6}$	-
δ_{res}	0	$0,58 \cdot 10^{-6}$	-	Rectangular	∞	1	$0,58 \cdot 10^{-6}$	-
δ_{volt}	0	-	0,577 V	Rectangular	∞	$0,003 \cdot 10^{-6} / V$	$0,0017 \cdot 10^{-6}$	-
$\delta_{temp uuc}$	0	-	2,89 °C	Rectangular	∞	$0,01 \cdot 10^{-6} / ^\circ C$	$0,03 \cdot 10^{-6}$	-
C_d	-0,000 123 pF	-	$0,24 \cdot 10^{-6}$	Normal	4	1	$0,24 \cdot 10^{-6}$	-
C_x	10,000 01 pF				> 100		$1,39 \cdot 10^{-6}$	-

Expanded Uncertainty :

$$U = k \cdot u(C_x) = 2,0 \cdot 1,39 \cdot 10^{-6} = 3 \cdot 10^{-6}$$

C.6 Uncertainty statement: NMI, Australia

The uncertainty statements presented below are for the 11th measurement (mean measurement date 27 May 2006). They are typical of the uncertainty statements for each measurement by the pilot laboratory at 1592 Hz.

APMP.EM-K4.1 (10 pF)								
Quantity	Estimate	Unit	Standard uncertainty	Unit	Effective DOF	Sensitivity coefficient	Unit	Contribution to rel. std. unc. ($\mu F/F$)
1. Realisation of SI farad:								
Calculable Capacitor	0	$\mu F/F$	0.0320	$\mu F/F$	6.4	1		0.0320
2. Working standard (50I)								
Transformer Ratio	0	$\mu F/F$	0.0039	$\mu F/F$	4078	1.41		0.0055
Bridge voltage coefficient	0	$\mu F/F$	0.0034	$\mu F/F$	7	1.41		0.0048
Bridge loading correction	0	$\mu F/F$	0.0015	$\mu F/F$	5	1.41		0.0021
Bridge balance injection	0	$\mu F/F$	0.0010	$\mu F/F$	3	1.41		0.0014
2-port definition	0	$\mu F/F$	0.0010	$\mu F/F$	3	1.41		0.0014
50I Voltage Coefficient	0	$\mu F/F$	0.0000	$\mu F/F$	5	1		0.0000
Bridge resolution	0	$\mu F/F$	0.0029	$\mu F/F$	inf	1.41		0.0041
Extrapolation (1)	0	$\mu F/F$	0.0088	$\mu F/F$	22	1		0.0088
3. Measurement of artefact								
Mean of 5 independent measurements (1)	0	$\mu F/F$	0.0100	$\mu F/F$	4	1		0.0100
Transformer Ratio	0	$\mu F/F$	0.0039	$\mu F/F$	4078	1		0.0039
Bridge resolution (2)	0	$\mu F/F$	0.0029	$\mu F/F$	inf	1.87		0.0054
Lead correction (1)	-0.021	$\mu F/F$	0.0011	$\mu F/F$	inf	1		0.0011
Temperature (1)	19.6	$^\circ C$	0.058	$^\circ C$	246	0.0014	$\mu F/F/K$	0.0001
Final Values:	-0.021	$\mu F/F$			11			0.036

Notes:

1. These uncertainties may vary slightly from measurement to measurement.
2. In measuring a 10 pF (100 pF) artefact, the bridge resolution is applied on five (four) occasions, two of which have a weight of 0.5.

C.7 Uncertainty statement: NMIJ/AIST, Japan

APMP.EM-K4.1 (10 pF)								
Quantity	Estimate	Unit	Standard uncertainty	Unit	Effective DOF	Sensitivity coefficient	Unit	Contribution to rel. std. unc. ($\mu\text{F}/\text{F}$)
Realisation of SI farad: reference standard 10 pF capacitance standard based on a quantized Hall resistance (QHR) (1),(2)	2.236	$\mu\text{F}/\text{F}$	0.120	$\mu\text{F}/\text{F}$	69977	1		0.120
Measurement of comparison artefact Mean of 7 independent measurements	-2.419	$\mu\text{F}/\text{F}$	0.011	$\mu\text{F}/\text{F}$	6	1		0.011
Lead correction (3)	-0.042	$\mu\text{F}/\text{F}$	0.017	$\mu\text{F}/\text{F}$	∞	1		0.017
Temperature correction: (23 °C \rightarrow 20 °C) (4)	-0.025	$\mu\text{F}/\text{F}$	0.003	$\mu\text{F}/\text{F}$	∞	1		0.003
Measurement voltage: 100 Vrms (5)			0.1	V	∞	0.003	$\mu\text{F}/\text{F}/\text{V}$	0.0003
Measurement frequency: 10000/2 π Hz (5)			0.005	Hz	∞	0.0002	$\mu\text{F}/\text{F}/\text{Hz}$	0.000001
Final Values:	-0.250	$\mu\text{F}/\text{F}$			40641			0.121

Notes:

1. The value of the QHR was determined based on the $R_{K-90} = 25\,812.807\ \Omega$ with a relative standard uncertainty of 1×10^{-7} .
2. Details of uncertainties are described in [10].
3. Leads effect was estimated by measuring the relative change of capacitance with changing the length of leads.
4. The temperature coefficient of capacitance with respect to changes in ambient laboratory temperature was measured to be $0.0085\ \mu\text{F}/\text{F}/\text{K}$ for Capacitor A (10 pF) and $-0.0018\ \mu\text{F}/\text{F}/\text{K}$ for Capacitor B (100 pF).
5. Type B uncertainty only.

C.8 Uncertainty statement: NMISA, South Africa

APMP.EM-K4.1 (10 pF)								
Quantity	Estimate	Unit	Standard uncertainty	Unit	Effective DOF	Sensitivity coefficient	Unit	Contribution to rel. std. unc. ($\mu\text{F}/\text{F}$)
Average of 33 pairs of readings			0.002	$\mu\text{F}/\text{F}$	32	1		0.002
Calibration of reference standard at BIPM cert. no. 53			0.05	$\mu\text{F}/\text{F}$	Infinite	1		0.05
Standard uncertainty associated with R_{K-90}			0.1	$\mu\text{F}/\text{F}$	Infinite	1		0.1
Drift of reference standard since last calibration			0.001732	$\mu\text{F}/\text{F}$	Infinite	1		0.0017
Reading resolution of the AH2500A (in % mode)			0.000289	$\mu\text{F}/\text{F}$	Infinite	1		0.00029
Voltage coefficient of reference standard			0.005774	$\mu\text{F}/\text{F}$	Infinite	1		0.0058
Voltage coefficient of unit under test (no contribution)			0	$\mu\text{F}/\text{F}$	Infinite	1		0
Correction for temperature influences			0.017321	$\mu\text{F}/\text{F}$	Infinite	1		0.017
Correction for powerline fluctuations			0.000577	$\mu\text{F}/\text{F}$	Infinite	1		0.00058
Final Values:	-0.183	$\mu\text{F}/\text{F}$			3.3×10^8			0.113

C.9 Uncertainty statement: NPL, India

The following uncertainty statements are those for measurements at 1592 Hz. Uncertainty statements for measurements at 1000 Hz differ where indicated.

APMP.EM-K4.1 (10 pF)								
Quantity	Estimate	Unit	Standard uncertainty	Unit	Effective DOF	Sensitivity coefficient	Unit	Contribution to rel. std. unc. ($\mu\text{F}/\text{F}$)
1. Realisation of SI farad: reference standard								
Value of reference standard (2)	9.9999923	pF	0.3	$\mu\text{F}/\text{F}$	400	1		0.3
Extrapolation to mean measurement date	--	--						
Temperature correction	25.0	$^{\circ}\text{C}$	0.05	$\mu\text{F}/\text{F}$	∞	1		0.05
Drift in Standards	2	years	0.2	$\mu\text{F}/\text{F}$	∞	1		0.2
Temp Hysteresis	1	$^{\circ}\text{C}$	0.01	$\mu\text{F}/\text{F}$	∞	1		0.01
Bridge resolution	0.04	$\mu\text{F}/\text{F}$	0.02	$\mu\text{F}/\text{F}$	∞	1		0.02
2. Working standard								
Extrapolation to mean measurement date	0							
Bridge calibration	0							
Bridge resolution	0							
Temperature correction	0							
Other (please specify)	0							
3. Measurement of comparison artefact								
Mean of n independent measurements (2)	9.9999876	pF	0.01	$\mu\text{F}/\text{F}$	8	1		0.01
Lead correction	0	$\mu\text{F}/\text{F}$	0	$\mu\text{F}/\text{F}$				0
Final Values: (2)	9.9999876				1020			0.38

Notes:

- On 26.7.04 it was noticed that value of 10 pF capacitor was deviated from earlier values. Its deviation from nominal value was -0.96 ppm in place of -1.24 . We could not repeat the measurement because it was to be dispatched to next laboratory. Therefore we have not included the measurement of 26.07.04, in report.
- Indicates those values that differ for measurements at a frequency of 1000 Hz.

C.10 Uncertainty statement: SCL, Hong Kong

APMP.EM-K4.1 (10 pF)								
Quantity	Estimate	Unit	Standard uncertainty	Unit	Effective DOF	Sensitivity coefficient	Unit	Contribution to rel. std. unc. ($\mu\text{F}/\text{F}$)
1. Realisation of SI farad: reference standard								
Value of reference standard	10.000 810	pF	1.5	$\mu\text{F}/\text{F}$	300	1		1.5
Extrapolation to mean measurement date	10.000 796	pF	3.6	$\mu\text{F}/\text{F}$	350	1		3.6
Temperature correction	0	$^{\circ}\text{C}$	0.1	K	100	5	$\mu\text{F}/\text{F}/\text{K}$	0.5
3. Measurement of comparison artefact								
Mean of 5 independent measurements	9.999 965	pF	0.24	$\mu\text{F}/\text{F}$	4	1		0.24
Bridge resolution	0	$\mu\text{F}/\text{F}$	0.29	$\mu\text{F}/\text{F}$	50	1		0.29
Lead correction	0	$\mu\text{F}/\text{F}$	0.06	$\mu\text{F}/\text{F}$	50	1		0.06
Temperature	23.0	$^{\circ}\text{C}$	1.73	K	50	0.01	$\mu\text{F}/\text{F}/\text{K}$	0.0173
Measurement voltage	15	V	49.1	V	50	0.003	$\mu\text{F}/\text{F}/\text{V}$	0.1473
Final Values:					490			4.0

C.11 Uncertainty statement: SIRIM, Malaysia

APMP.EM-K4.1 (10 pF)									
Quantity	Identifier	Estimate	Unit	Standard uncertainty	Unit	Effective DOF	Sensitivity coefficient	Unit	Contribution to rel. std. unc. (μF/F)
1. Reference Standard									
Assigned Value of Ref. Cap.	C _{Ref} _{BIPM}	9.9999649	pF	0.050	μF/F	50	1		0.050
Assigned Value of R _{K-90}	C _{R_{K-90}} _{BIPM}	25812.807	Ω	0.100	μF/F	50	1		0.100
Transportation effects	δC _{Ref} _{Transport}	-	pF	0.225	μF/F	∞	1		0.225
Temp. coefficient of Ref. Cap.	δC _{Ref} _{Tambient}	-	pF	0.002	μF/F	∞	1		0.002
Temp. hysteresis of Ref. Cap.	δC _{Ref} _{Thysteresis}	-	pF	0.029	μF/F	∞	1		0.029
Voltage coefficient of Ref. Cap.	δC _{Ref} _{testvoltage}	-	pF	0.001	μF/F	∞	1		0.001
Mains line coeff. of Ref. Cap.	δC _{Ref} _{mainsvoltage}	-	pF	0.000	μF/F	∞	1		0.000
Change in the value of Ref. Cap with time	δC _{Ref} _{time}	-	pF	0.632	μF/F	∞	1		0.632
2. Measurement of comparison artefact									
Mean bridge readings	Decade _{Mean}	0.001510	pF	0.258	μF/F	9	1		0.258
Bridge calibration	ΔBridge _{Corr}	-0.001471	pF	0.401	μF/F	8	1		0.401
Bridge GR 1615 resolution	δ _{resl}	-	pF	0.289	μF/F	∞	1		0.289
Lead Correction	δX _{lead}	-	pF						
Ambient Temperature		22.8	°C			∞	1.00E-07		0.002
Correction to temp differing from 20 deg. C	ΔTemp _{Corr}	-0.00000028	pF	0.029	μF/F	∞	1.00E-06		0.000
Measurement voltage		100	V			∞	3.00E-08		0.001
Measurement frequency		1000	Hz						
Final Values:		10.000004	pF			157			0.874

Notes:

- $C_x = C_{Ref} + \text{Decade}_{\text{Mean}} + \Delta\text{Bridge}_{\text{Corr}} + \delta X_{\text{Tambient}} + \delta X_{\text{testvoltage}} + \delta_{\text{resl}} + \delta X_{\text{lead}}$
- $C_{\text{ref}} = C_{\text{RefBIPM}} + C_{\text{R}_{K-90} \text{ BIPM}} + \delta C_{\text{RefTambient}} + \delta C_{\text{RefThysteresis}} + \delta C_{\text{Reftestvoltage}} + \delta C_{\text{Refmainsvoltage}} + \delta C_{\text{Reftime}} + \delta C_{\text{RefTransport}}$

C.12 Uncertainty statement: A*STAR, Singapore

Uncertainty statements for measurements at 1592 Hz are given below. Uncertainty statements for measurements at 1000 Hz differ only in the uncertainty component relating to repeatability and are therefore omitted.

SPRING								
UNCERTAINTY STATEMENT : APMP.EM-K4.1 (10 pF @ 1592 Hz)								
Capacitor A : Serial Number 01349								
Quantity	Estimate	Unit	Standard uncertainty	Unit	Effective degrees of freedom	Sensitivity coefficient	Unit	Contribution to the relative standard uncertainty (μF/F)
1 Reference Standard								
1.1 Realisation of SI farad								
1.1.2 Reference standard calibration uncertainty	0.70	μF/F	0.35	μF/F	∞ (7)	1		0.35
1.2 Derivation of value of Reference Standard								
1.2.1 Stability (1)								
1.2.1 Stability (1)	0.40	μF/F	0.23	μF/F	∞ (7)	1		0.23
1.2.2 Chassis temperature (2)								
1.2.2 Chassis temperature (2)	30.07	°C	0.68	°C	∞ (7)	0.01	μF/F/°C	0.0039
1.2.3 Measurement voltage (3)								
1.2.3 Measurement voltage (3)	100	V	1.7	V	∞ (7)	0.003	μF/F/V	0.0029
3 Measurement of comparison artefact								
3.1 Bridge calibration (4)								
3.1 Bridge calibration (4)	0.40	μF/F	0.23	μF/F	∞ (7)	1		0.23
3.2 Bridge resolution								
3.2 Bridge resolution	0.010	μF/F	0.0058	μF/F	∞ (7)	1		0.0058
3.3 Repeatability								
3.3 Repeatability	0.063	μF/F	0.020	μF/F	9	1		0.020
3.4 Measurement Conditions								
3.4.1 Ambient temperature (5)								
3.4.1 Ambient temperature (5)	23	°C	0.58	°C	∞ (7)	0.01	μF/F/°C	0.0033
3.4.2 Measurement voltage (3)								
3.4.2 Measurement voltage (3)	100	V	1.7	V	∞ (7)	0.003	μF/F/V	0.0029
3.4.3 Measurement frequency (6)								
3.4.3 Measurement frequency (6)	1592	Hz	-	1.73205	∞ (7)	-		-
Final Values : (combined standard uncertainty)								
0.5								

Notes :

1 due to drift of reference standard

2 reference standard calibrated at chassis temperature of 28.9 °C

3 AC test signal voltage; 100 V ± 3 %, reference values were calibrated at 100

4 includes stability, non-linearity, temperature coefficient, leads

5 ambient temperature was 23 ± 1.0 °C

6 frequency was derived by synthesis from a frequency primary standard so effect of frequency uncertainty is insignificant

7 type B uncertainty, assuming rectangular distribution

C.13 Uncertainty statement: VNIIM, Russia

APMP.EM-K4.1 (10 pF)								
Quantity	Estimate	Unit	Standard uncertainty	Unit	Effective DOF	Sensitivity coefficient	Unit	Contribution to rel. std. unc. ($\mu\text{F}/\text{F}$)
1. Realisation of SI farad: VNIIM calculable capacitor								
Geometrical imperfections	0.2	pF	0.08	$\mu\text{F}/\text{F}$	13	1		0.08
Laser interferometer	0	$\mu\text{F}/\text{F}$	0.03	$\mu\text{F}/\text{F}$	8	1		0.03
Transformer bridge	0	$\mu\text{F}/\text{F}$	0.06	$\mu\text{F}/\text{F}$	13	1		0.06
Insufficient sensitivity	0	$\mu\text{F}/\text{F}$	0.09	$\mu\text{F}/\text{F}$	6	1		0.09
Repeatability	0	$\mu\text{F}/\text{F}$	0.10	$\mu\text{F}/\text{F}$	6	1		0.10
2. Working standard (10 pF) (1)								
Build-up from calculable capacitor	0	$\mu\text{F}/\text{F}$	0.04	$\mu\text{F}/\text{F}$	8	1		0.04
Extrapolation to mean measurement date	0	$\mu\text{F}/\text{F}$	0.02	$\mu\text{F}/\text{F}$	50	1		0.02
Bridge calibration	0	$\mu\text{F}/\text{F}$	0.02	$\mu\text{F}/\text{F}$	13	1		0.02
Temperature correction	0	$\mu\text{F}/\text{F}$	0.03	$\mu\text{F}/\text{F}$	20	1		0.03
3. Measurement of comparison artefact								
Mean of 7 independent measurements	- 0.22	$\mu\text{F}/\text{F}$	0.018	$\mu\text{F}/\text{F}$	6	1		0.018
Bridge resolution	0	$\mu\text{F}/\text{F}$	0.02	$\mu\text{F}/\text{F}$	13	1		0.02
Lead correction	-0.017	$\mu\text{F}/\text{F}$	0.005		20	1		0.005
Temperature correction	-0.004	$\mu\text{F}/\text{F}$	0.1	$^{\circ}\text{C}$	13	0.01	$\mu\text{F}/\text{F}/\text{K}$	0.001
Final Values:	(2)	- 0.24		$\mu\text{F}/\text{F}$	34			0.182

Notes:

1. The group standard for maintenance of the national unit of capacitance.
2. Calculated value of effective degrees of freedom is truncated to the next lower integer.

Appendix D: Optional measurements: Dissipation factor

Reporting of the dissipation factor for each capacitor was optional. Each capacitor is modelled as an ideal capacitor, of capacitance C , in parallel with an ideal resistor, of conductance G . The admittance of the capacitor is therefore $Y = G + j\omega C$ and the dissipation factor $D = G/\omega C$. Three participants made measurements of the dissipation factor. Their results are shown in Table A - 3.

Participant	Measurement Voltage (V)	$f = 1000$ Hz		$f = 1592$ Hz	
		D (μ rad)	$U_{95\%}$ (μ rad)	D (μ rad)	$U_{95\%}$ (μ rad)
NPLI	100	0	0.3	0	0.3
KRISS	100	0.71	0.03	0.71	0.03
VNIIM	98.5	0.4	0.5	-	-

Table A - 3 Dissipation factor measurements.

Appendix E: Additional details of the calculation of pair-wise degrees of equivalence within APMP.EM-K4.1

E.1 Estimating the covariance due to derived traceability

There will be a correlation between x_i and x_j if laboratory i derives its traceability from laboratory j , or if laboratory i and laboratory j both derive their traceability from a third laboratory which may or may not be a participant in the comparison.

The covariance $u(m_i, m_j) = u^2(m_{ij})$ between measurements m_i and m_j is estimated as the square of the standard uncertainty, u_r , associated with the systematic effects in the uncertainty of the laboratory providing traceability [11]. The standard uncertainty u_r is estimated from the uncertainty statements provided by participants or from published uncertainty statements. In the absence of explicit information, the number of degrees of freedom is assumed to be infinite. The estimated values are summarised Table A - 4.

Laboratory providing traceability	Estimate of u_r (μ F/F)	Degrees of freedom ν_r	Reference
NMIA	0.033	7.4	Appendix 0
BIPM	0.035	infinite	[12]
NPL, UK	0.040	infinite	[12]
VNIIM	0.180	32	Appendix C.13

Table A - 4 Estimated standard uncertainty, u_r , associated with a common reference standard.

KRISS derives its traceability from a number of laboratories (refer to Appendix C.3). The covariance $u(x_i, x_j)$, where KRISS is the i th laboratory, is calculated using the following estimated relative contributions to the value of KRISS's reference standard: NMIA 10%, BIPM 40%, VNIIM 30% and NIST 20%. As these values can be adjusted significantly without affecting the degrees of equivalence, a more rigorous calculation was not considered necessary.

E.2 Estimating the covariance due to common technique

There will be a correlation between x_i and x_j if laboratories i and j both derive their measurements from the dc quantum Hall effect using the agreed value of the von Klitzing constant (R_{K-90}). In this

case the covariance $u(x_i, x_j)$ between measurements x_i and x_j is estimated as the square of the standard uncertainty associated with R_{K-90} . Other possible correlations due to the use of common techniques were not considered.

E.3 Treating the correlation arising from the normalisation of participants results

There is a correlation between x_i and x_j due to the normalisation of participant results described in Section 6.1. Rather than treating the correlations directly, equation (6) is reduced to an expression involving mutually uncorrelated variables only. The measurements m_i and m_j are modelled as:

$$\begin{aligned} m_i &= m_{ij} + m_i' \\ m_j &= m_{ij} + m_j' \end{aligned} \quad (\text{A.1})$$

where m_{ij} is an unknown measurement bias common to measurements i and j due to a derived traceability or to a common measurement technique. It follows that m_{ij} , m_i' and m_j' are mutually uncorrelated so that

$$\begin{aligned} u^2(m_i) &= u^2(m_{ij}) + u^2(m_i') \\ u^2(m_j) &= u^2(m_{ij}) + u^2(m_j') \end{aligned} \quad (\text{A.2})$$

Rewriting (6) using (2), (4) and (A.1) gives:

$$\begin{aligned} d_{i,j} &= m_i - m_j - (p_i - p_j) \\ &= m_i' - m_j' - \left[a_1(t_i - t_j) - a_2 \left(\frac{f_i - f_j}{1592 - 1000} \right) \right] \end{aligned} \quad (\text{A.3})$$

Equation (A.3) represents the pair-wise degrees of equivalence of participating institutes (other than the pilot laboratory) expressed in terms of mutually uncorrelated variables only. For the pilot laboratory m_i' or m_j' will be correlated with a_1 . It can be shown that the effect of treating this correlation explicitly is to decrease the uncertainty $u(d_{i,j})$ by less than 0.002 $\mu\text{F}/\text{F}$. We therefore calculate the standard uncertainty and degrees of freedom for the pair-wise degrees of equivalence for all participating institutes as

$$u^2(d_{i,j}) = u^2(m_i') + u^2(m_j') + u^2(a_1) \cdot (t_i - t_j)^2 + u^2(a_2) \cdot \left(\frac{f_i - f_j}{1592 - 1000} \right)^2 \quad (\text{A.4})$$

and

$$v(d_{i,j}) = \frac{u^4(d_{i,j})}{\frac{u^4(m_i')}{v(m_i')} + \frac{u^4(m_j')}{v(m_j')} + \frac{u^4(a_1) \cdot (t_i - t_j)^4}{v(a_1)} + \frac{u^4(a_2) \cdot \left(\frac{f_i - f_j}{1592 - 1000} \right)^4}{v(a_2)}} \quad (\text{A.5})$$

Here we have assumed that $u(t_i)$, $u(t_j)$, $u(f_i)$ and $u(f_j)$ are negligible. Substituting (A.1) and (A.2) into (A.4) and (A.5) gives (8) and (9). Note that the explicit calculation of m_i' and m_j' is not required, since d_{ij} is calculated from (6).

E.4 Summary of values used in calculation

$u(m_{ij})$			1	2	3	4	5	6	7	8	9	10	11	12	13
LAB	i,j														
NMIA	1	-	0	0	0	0.033	0	0.033	0	0	0	0	0	0	0
NIM	2	0	-	0	0	0	0	0	0	0	0	0	0	0	0
SCL	3	0	0	-	0	0	0.1	0	0	0	0.108	0.1	0.1	0	0
NPLI	4	0	0	0	-	0	0	0	0	0	0	0	0	0	0
KIM-LIPI	5	0.033	0	0	0	-	0	0.003	0	0	0	0	0	0	0
NMIJ/AIST	6	0	0	0.1	0	0	-	0	0	0	0.1	0.1	0.100	0	0
KRISS	7	0.033	0	0	0	0.003	0	-	0.014	0.054	0	0.014	0	0	0
SIRIM	8	0	0	0.1	0	0	0.1	0.014	-	0	0.1	0.106	0.1	0	0
VNIM	9	0	0	0	0	0	0	0.054	0	-	0	0	0	0	0
A*STAR	10	0	0	0.108	0	0	0.1	0	0.1	0	-	0.1	0.1	0	0
NMISA	11	0	0	0.1	0	0	0.1	0.014	0.106	0	0.1	-	0.1	0	0
CMS	12	0	0	0.1	0	0	0.100	0	0.1	0	0.1	0.1	-	0	0
NIMT	13	0	0	0	0	0	0	0	0	0	0	0	0	0	-

$\nu(m_{ij})$			1	2	3	4	5	6	7	8	9	10	11	12	13
LAB	i,j														
NMIA	1	-	∞	∞	∞	∞	7	∞	7	∞	∞	∞	∞	∞	∞
NIM	2	∞	-	∞	∞	∞	∞	∞	∞	∞	∞	∞	∞	∞	∞
SCL	3	∞	∞	-	∞	∞	∞	∞	∞	∞	∞	∞	∞	∞	∞
NPLI	4	∞	∞	∞	-	∞	∞	∞	∞	∞	∞	∞	∞	∞	∞
KIM-LIPI	5	7	∞	∞	∞	-	∞	7	∞	∞	∞	∞	∞	∞	∞
NMIJ/AIST	6	∞	∞	∞	∞	∞	-	∞	∞	∞	∞	∞	∞	∞	∞
KRISS	7	7	∞	∞	∞	∞	7	∞	-	∞	32	∞	∞	∞	∞
SIRIM	8	∞	∞	∞	∞	∞	∞	∞	∞	-	∞	∞	∞	∞	∞
VNIM	9	∞	∞	∞	∞	∞	∞	32	∞	∞	-	∞	∞	∞	∞
A*STAR	10	∞	∞	∞	∞	∞	∞	∞	∞	∞	∞	-	∞	∞	∞
NMISA	11	∞	∞	∞	∞	∞	∞	∞	∞	∞	∞	∞	-	∞	∞
CMS	12	∞	∞	∞	∞	∞	∞	∞	∞	∞	∞	∞	∞	-	∞
NIMT	13	∞	∞	∞	∞	∞	∞	∞	∞	∞	∞	∞	∞	∞	-

Appendix F: References

- [1] Mutual Recognition Arrangement “Mutual Recognition of National Measurement Standards and of Calibration and Measurement Certificates Issued by National Metrology Institutes - Arrangement Drawn up by the International Committee of Weights and Measures under the Authority Given to it in the Metre Convention.” http://www.bipm.org/utis/en/pdf/mra_2003.pdf 15 January 2007.
- [2] Witt T. J. “Pressure coefficient of some Zener diode-based electronic voltage standards,” *IEEE Trans. Instrum. Meas.*, Vol. 48, No. 2, 1999, pp. 329-332.
- [3] Delahaye F. and Witt T. J. “Linking the results of key comparisons CCEM-K4 with the 10 pF results of EUROMET.EM-K4,” *Metrologia Tech. Suppl.*, Vol. 39, 01005, 2002.
- [4] Thompson A. M. and Lampard D. G. "A New Theorem in Electrostatics and its Application to Calculable Standards of Capacitance", *Nature*, Vol. 177, 1956, p. 888.
- [5] Thompson A. M. "The Cylindrical Cross-capacitor as a Calculable Standard", *Proc. IEE*, Vol. 106, Part B No. 27, 1959, pp. 307-310.
- [6] Clothier W. K. "A Calculable Standard of Capacitance", *Metrologia*, Vol. 1, No. 2, 1965, pp 35-56.
- [7] Small G. W. "Twenty Years of SI Ohm Determinations at NML", *IEEE Trans. Instrum. Meas.*, Vol. IM-36, No. 2, 1987, pp. 190-195.
- [8] McGregor M. C., Hersh J.F., Cutkosky R.D., Harris F.R. and Kotter F.R. “New apparatus at the National Bureau of Standards for absolute capacitance measurement”, *IRE Trans. Instrum.*, v.7, 1958, pp. 253-61
- [9] <http://physics.nist.gov/cuu/Constants/index.html> 15 January 2007
- [10] Nakamura Y., Nakanishi M. and Endo T. “Measurement of frequency dependence of standard capacitor based on the QHR in the range between 1 kHz and 1.592 kHz” *IEEE Trans. Instrum. Meas.*, vol. 50, No. 2, pp. 290-293, 2001
- [11] Sutton C. M. “Analysis and linking of international measurement comparisons” *Metrologia*, Vol. 41, pp.272-277, 2004.
- [12] Delahaye F. and Awan S.A. “Bilateral Comparison of 10 pF and 100 pF Capacitance Standards between the NPL and the BIPM, April/May 2002,” *Rapport BIPM-03/01*, 2003.

Appendix G: Comparison protocol

The comparison protocol is attached.

**Protocol
for**

APMP.EM-K4.1

APMP Key Comparison of Capacitance at 10 pF

and

APMP.EM-S7

APMP Supplementary Comparison of Capacitance at 100 pF

Contents

1. Introduction	47
2. Travelling Artefacts	47
(a) Description.....	47
(b) Operation	49
3. Transport of Artefacts	49
(a) Customs arrangements.....	49
(b) Transport case.....	49
(c) Damage	49
(d) Receipt of travelling standard	49
(e) Measurement Period	50
(f) Dispatch of travelling standard	50
4. Measurement of the capacitors	51
(a) Preparation.....	51
(b) Laboratory conditions.....	51
(c) Measurement voltage.....	51
(d) Measurement frequency	51
(e) Measurement leads	51
(f) Recorded quantities.....	51
(g) Temperature dependence of capacitance.....	51
5. Reporting of results.....	52
(a) General comments	52
(b) Results	52
(c) Uncertainty	52

6. Notes	53
7. Comparison costs.....	53
8. Inquiries	54
Appendix I: Schedule	63

11 Introduction

A key comparison of capacitance at 10 pF and a supplementary comparison of capacitance at 100 pF is to be conducted between participating APMP member laboratories. Its aim is to provide participating laboratories with the opportunity to intercompare national standards of capacitance within the Region, and to gain experience and knowledge in this field.

It is proposed that the values from this key comparison in the APMP region be linked to the international key comparison CCEM-K4 carried out between 1994 and 1996. The linking laboratories will be NML CSIRO (Australia), MSL IRL (New Zealand), NIM (China) and VNIIM (Russian Federation).

The National Measurement Laboratory (NML), Australia, will act as the pilot laboratory for the comparison. Dr Leigh Johnson will act as the coordinator. The members of the support group for the comparison are Dr. Sze Wey Chua, SPRING Singapore, Dr Rae Duk Lee, KRISS Korea and Mr Andrew Corney, MSL New Zealand.

It is expected that the comparison will start towards the end of 2003. Each participating laboratory should ensure that the time required for their measurements and for transportation to the next laboratory does not exceed four weeks. It is anticipated that the comparison measurements will be completed within two years.

The circulation of the capacitors will be organised in loops of no more than five laboratories to allow close monitoring of the behaviour of the standard capacitors.

In the event of failure of a standard the pilot laboratory should be informed. The pilot laboratory will consider whether to continue the comparison with the remaining capacitor, substitute an alternative standard or abandon the comparison.

This protocol has been developed according to the Guidelines for CIPM key comparisons, available on the BIPM web site:

<http://www.bipm.fr/pdf/guidelines.pdf>

12 Travelling Artefacts

12.1 Description

The artefacts are a 10 pF and a 100 pF Andeen-Hagerling AH11A fused silica capacitance standard mounted in a single AH1100 capacitance standard frame. Details of the two comparison capacitors are given in Table 6 and the manufacturer's specifications for this type of standard are given in Table 7. The AH1100 frame is a standard width bench-top or rack-mountable frame. Each AH11A capacitance standard includes a temperature-controlled oven that is powered via the AH1100 frame. The frame also monitors internal power voltages and temperatures.

More detailed information on this type of capacitance standard is available on the manufacturers web site:

<http://www.andeen-hagerling.com/ah11a.htm>

The capacitors are fitted with BNC co-axial terminations. Co-axial measuring leads with BNC to MUSA connectors will be supplied with the capacitors, together with MUSA-GR874 adapters and MUSA-BNC adapters.

A power line cord (standard IEC connector to Australian three-pin plug) will be supplied to power the standard. Participants may need an adapter or a power line cord appropriate to their country.

Comparison identifier	P2-APMP.EM-K4.1	P1-APMP.EM-S7
Comparison type	Key	Supplementary
Nominal value of capacitance	10 pF	100 pF
Capacitor identifier	Capacitor A	Capacitor B
Serial number of capacitor	01349	01350

Table 6 Details of the comparison capacitors.

Operating parameters:	
12.1.1.1.1 Power voltage ranges	85 to 115, 102 to 138, 187 to 253 and 204 to 276 volts rms
Power frequency	48 to 440 Hz
Warm up time from power-on	30 minutes
Operating temperature range	10° to 40° C
Maximum allowable applied voltage	250 volts peak
Operating humidity range	0 to 85% relative humidity, non-condensing
Sensitivity of AH11A capacitance standard:	
12.1.1.1.2 Temperature coefficient relative to a change in ambient temperature	0.01 $\mu\text{F}/\text{F}/\text{K}$
12.1.1.1.3 AC voltage coefficient	0.003 $\mu\text{F}/\text{F}/\text{volt rms}$ at 1 kHz
12.1.1.1.4 Sensitivity to power line voltage changes	0.0003 $\mu\text{F}/\text{F}$ per 1% change in power line voltage
12.1.1.1.5 Hysteresis from mechanical shock	0.05 $\mu\text{F}/\text{F}$
12.1.1.1.6 Hysteresis from temperature cycling	0.05 $\mu\text{F}/\text{F}$
12.1.1.1.7 DC voltage coefficient	0.0001 $\mu\text{F}/\text{F}/\text{V}$
Transport information:	

Storage temperature range	-40° to +75° C
AH 1100 frame size	8.9 cm high and 38.1 cm deep behind the front panel.
Total weight of AH1100 frame and two AH11A capacitors	8.4 kg

Table 7 Manufacturer's specifications for the Andeen-Hagerling AH11A standard capacitor and AH1100 frame.

12.2 Operation

The AH 1100/11A Operation and Maintenance Manual will be included with the shipment. Participants should familiarise themselves with the operation of the standards before proceeding. In particular, the correct line voltage must be selected and a corresponding fuse fitted **before applying power to the unit.**

Measurements should not be taken until the OVEN NOT READY indicator stops blinking. If the OVEN NOT READY indicator continues blinking for more than an hour after applying power to the standard or starts blinking during measurements, please contact the pilot laboratory.

Note that the HIGH and LOW terminals of the capacitors have different properties. Refer to Chapter 2 of the AH 1100/11A Operation and Maintenance Manual for more information.

13 Transport of Artefacts

13.1 Customs arrangements

The artefacts will be transported using an ATA Carnet for customs clearance where possible. A separate comparison loop will be organised for those participants that do not qualify for the ATA scheme.

13.2 Transport case

The capacitors will be transported in an aluminium case. The dimensions of the transport case are 750 mm x 750 mm x 450 mm. The case weighs 27 kg giving a total shipping weight of approximately 36 kg.

Participants are requested to ensure that handling and transport shock is kept to a minimum.

13.3 Damage

Please report to the pilot laboratory any damage of the artefacts or accompanying items.

13.4 Receipt of travelling standard

On receipt of the travelling standard:

1. Inspect the outside of the transport case for any signs of physical damage. A shock monitor is attached to the outside of the transport case. Check that the monitor label has not been activated.
2. Open the transport case and check that the contents are complete (refer to Packing List for list of contents). In particular, please check that the Carnet is with the shipment.

3. Notify **both the pilot laboratory and the sending laboratory** of the receipt of the travelling standards using the Artefact Received Fax Form provided. Fax numbers for each participating laboratory are given in the Participant List.
4. Retain or make a copy of all shipping documentation. Please do not dispose of this documentation until the comparison is complete. **DO NOT** retain the original copy of the carnet.
5. A copy of the AH 1100/11A Operation and Maintenance Manual is included in the shipment. If you have not used this type of standard before, please familiarise yourself with the operation of the standards before proceeding.
6. The AH1100 frame containing the two capacitance standards should be removed from the transport case. Please do not open the AH1100 frame. Please do not remove the AH11A capacitance standards from the frame. Remove the travelling plug from the power line cord receptacle at the back of the bridge. Before applying power to the unit, select the correct line voltage and fit an appropriate fuse, referring to pages 1-5 and 1-6 of the AH 1100/11A Operation and Maintenance Manual.
7. Apply power to the frame and wait until the oven temperature is stable (**OVEN NOT READY** indicator stops blinking). Typically, the oven will take 20 minutes to stabilise. For the most precise measurements, it is recommended that the standards are left to stabilise for two to three days.

13.5 Measurement Period

The draft comparison schedule allows a total of four weeks for each laboratory. The four week period starts when the travelling artefact arrives in the participant's country and ends when the travelling artefact arrives in the following participant's country. It is anticipated that participants will have at least a two week measurement period.

Arrangements for shipping the artefact to the next scheduled laboratory should be in place before the end of the measurement period. As a courtesy, contact should be made with the next scheduled laboratory regarding shipping, particularly if the anticipated dispatch date is earlier or later than scheduled.

Participants are requested to inform the pilot laboratory if delays to the Schedule have occurred or are likely to occur. If unforeseen circumstances prevent a laboratory from carrying out or completing measurements within the scheduled period, the pilot laboratory will, in most cases, request that the artefacts be sent to the next scheduled laboratory without delay. If time allows, the artefacts will be returned to the laboratory for the completion of measurements at a later date.

13.6 Dispatch of travelling standard

On completion of measurements each participant is requested to ship the travelling standard to the next scheduled laboratory.

Repack the artefact and all accompanying items in the transport case. Please check that the contents are complete (refer to Packing List for list of contents). In particular, please ensure that the carnet travels with the artefact but do **NOT** pack the Carnet inside the transport case.

Addresses for dispatching the artefacts are given in the Participant List.

On dispatch of the travelling standard, notify **both the pilot laboratory and the recipient laboratory** using the Artefact Shipped Fax Form provided. Fax numbers for each participating laboratory are given in the Participant List.

14 Measurement of the capacitors

14.1 Preparation

The artefacts should be unpacked and left to stabilise according to the instructions given in Section 13.4 “Receipt of travelling standard”.

14.2 Laboratory conditions

Refer to the manufacturer’s specifications listed in Table 7.

14.3 Measurement voltage

The measurement voltage must not exceed a peak value of 250 V.

The preferred measuring voltage for both capacitor is 100 V(rms).

An alternate measuring voltage for the 100 pF capacitor is 10 V(rms).

The manufacturer’s specification for the voltage coefficient of the capacitors is 0.003 $\mu\text{F}/\text{F}/\text{V}(\text{rms})$ at 1 kHz. Participants may choose to include this as a source of uncertainty if they use measuring voltages other than those listed above.

14.4 Measurement frequency

The preferred measurement frequency is 1592 Hz ($\omega = 10^4 \text{ rad}\cdot\text{s}^{-1}$). Measurements may be made at a frequency of 1000 Hz instead of, or as well as, 1592 Hz.

14.5 Measurement leads

Participants may use any of the leads and adapters supplied with the capacitors, or may choose to use their own leads. Please note that participants are responsible for determining any necessary corrections for leads or adapters to obtain the capacitance **at the terminals on the AH1100 frame**.

14.6 Recorded quantities

For each measurement, the following quantities should be recorded:

1. the measurement date
2. the applied voltage,
3. the measurement frequency,
4. the measured capacitance,
5. the air temperature in the vicinity of the measuring apparatus and the capacitors, and
6. the chassis temperature and the drift reading (these quantities need not be included in the report but should be noted on the Artefact Shipped Fax Form)

14.7 Temperature dependence of capacitance

The temperature coefficient of capacitance with respect to changes in ambient laboratory temperature is less than 0.01 $\mu\text{F}/\text{F}/\text{K}$ for both capacitors. No corrections should be made for

ambient laboratory temperature. Participants may choose to include a component for ambient laboratory temperature in their uncertainty budget if the ambient laboratory temperature differs from 20 °C.

15 Reporting of results

15.1 General comments

A full measurement report in English containing all relevant data and uncertainty estimates is to be forwarded to the coordinator within six weeks of completing measurement of the capacitors. Prompt reporting is encouraged to allow rapid identification of problems with the travelling artefacts. The report should include a description of the measurement method (facilities and methodology), the traceability to the SI, and the results, associated uncertainty and number of degrees of freedom.

Participants are encouraged to submit their results using the Measurement Report Form. Participants may submit their results in the format of Calibration Certificates normally issued by their laboratory provided the all the required data are either included or attached.

15.2 Results

The capacitance **at the terminals on the AH1100 frame** is to be reported for each capacitor.

The mean measurement date, the measurement frequency and the applied voltage must also be reported for each capacitor.

Details of any corrections that have been applied (for example, bridge corrections or leads corrections) must be given.

All results should be clearly identified with the serial number of the capacitor (refer to Table 6).

15.3 Uncertainty

The uncertainty calculation should be carried out in accordance with the ISO “Guide to the expression of uncertainty in measurement”. All contributions to the uncertainty of measurement should be listed separately in the report and identified as either Type A or Type B uncertainties. The overall uncertainty, as calculated from the individual uncertainties, should be stated. Uncertainties are to be evaluated at the level of one standard uncertainty and the number of degrees of freedom are to be reported. The main uncertainty components are expected to be:

- Experimental standard uncertainty of the mean of n independent measurements (Type A)
- Uncertainty in the primary standard or working standard against which the artefacts are measured (Type B)
- Uncertainty due to leads correction (Type B)

Participants may need to consider the following additional sources of uncertainty, depending on their individual circumstances:

- Uncertainty due to ambient laboratory temperature differing from 20 °C (see Section 14.7) (Type B)
- Uncertainty due to measurement voltage differing from recommended level (see Section 14.3) (Type B)
- Uncertainty due to power line changes (refer to Table 7) (Type B)

- Uncertainty due to frequency (Type B)

Participants may need to include additional sources of uncertainty appropriate to their measurement system.

16Notes

If any laboratory feels that it would have difficulty meeting any of the above requirements, rather than withdraw from the comparison, it should discuss the problem with the coordinator so that satisfactory arrangements can be made. It is expected that amongst participating laboratories, uncertainties will cover a wide range (according to local requirements). This should not be seen as a deterrent to participating in the comparison.

17Comparison costs

Each participating laboratory is responsible for meeting the costs of its own measurements.

In addition, each participating laboratory is responsible for meeting all costs, and making all arrangements, relating to the transport of the travelling artefact from the time the artefact arrives in their country to the time the artefact arrives in the country of the next participating laboratory. Costs may include (but are not limited to) costs associated with the arrival in the country (eg. customs charges, quarantine fees, broker fees, carrier charges from the port of arrival to the participants laboratory) and costs associated with transporting the artefacts from the participant's laboratory to the international port in the next scheduled country closest to the next participant's laboratory. International carriage is to be by air.

18Inquiries

All inquiries or communications relating to the comparison should be addressed in the first instance to the comparison co-ordinator, Leigh Johnson.

18.1.1.1 Dr Leigh Johnson

National Measurement Telephone: + 61 2 8467 3529

Institute 18.1.1.3 Fax: + 61 2 8467 3610

P. O. Box 218 E-mail:

18.1.1.1.1 Lindfield

NSW 2070

leigh.johnson@measurement.gov.au

18.1.1.2 AUSTRALIA

An alternative contact for urgent inquiries or communications relating to shipment:

18.1.1.4 Mrs Darien Northcote

National Measurement Telephone: + 61 2 8467 3574

Institute 18.1.1.6 Fax: + 61 2 8467 3719

P. O. Box 218 E-mail:

18.1.1.4.1 Lindfield

NSW 2070

darien.northcote@measurement.gov.au

18.1.1.5 AUSTRALIA

Further information and progress reports for the comparison will be available on the NML website at:

<http://www.measurement.gov.au/>

Appendix II: Participants

M0	NML, CSIRO (AUSTRALIA)	<p>Contact Person: Dr Leigh Johnson</p> <p>E-mail: leigh.johnson@measurement.gov.au</p> <p>Telephone Number: +61 2 8467 3529</p> <p>Fax Number: +61 2 8467 3610</p> <p>Delivery Address: National Measurement Institute (NMI) Bradfield Road Lindfield NSW 2070 AUSTRALIA</p>
M1	NMIJ (JAPAN)	<p>Contact Person: Dr Yasuhiro Nakamura</p> <p>E-mail: y.nakamura@aist.go.jp</p> <p>Telephone Number: +81 29 861 5659</p> <p>Fax Number: +81 29 861 3469</p> <p>Delivery Address: National Metrology Institute of Japan (NMIJ/AIST) AIST Tsukuba Central 2-2 1-1-1 Umezono Tsukuba-shi Ibaraki 305-8568 JAPAN</p>
M2	KRISS (KOREA)	<p>Contact Person: Dr Rae Duk Lee</p> <p>E-mail: rdlee@kriss.re.kr</p> <p>Telephone Number: +82 42 868 5150</p> <p>Fax Number: +82 42 868 5018</p>

Delivery Address: Korea Research Institute of Standards and
Science (KRISS)

Division of Electromagnetic Metrology

P O Box 102

Yusong

Taejon 305-600

KOREA

M3	SPRING (SINGAPORE)	<p>Contact Person: Jinni Lee</p> <p>E-mail: jinni@spring.gov.sg</p> <p>Telephone Number: +65 6773 9823</p> <p>Fax Number: +65 6773 9804</p> <p>Delivery Address: Standards, Productivity and Innovation Board (SPRING Singapore)</p> <p>1 Science Park Drive 118211 SINGAPORE</p>

M4	CMS (CHINESE TAIPEI)	<p>Contact Person: Jimmy C Hsu</p> <p>E-mail: JimmyCHsu@itri.org.tw</p> <p>Telephone Number: +886 3 574 3726</p> <p>Fax Number: +886 3 572 4952</p> <p>Delivery Address: Center for Measurement Standards (CMS) Industrial Technology Research Institute E200, BLDG 16 321 Kuang Fu Road, Section 2 Hsinchu 30042 CHINESE TAIPEI</p>

M7	NPL (INDIA)	<p>Contact Person: A K Saxena</p> <p>E-mail: aksaxena@mail.nplindia.ernet.in</p> <p>Telephone Number: +91 11 2574 26 10 or 11 or 12: Ext 2291, 2211, 2259</p> <p>Fax Number: +91 11 2572 6938 or 91 11 2572 6952</p> <p>Delivery Address: National Physical Laboratory (NPL) Director National Physical Laboratory Dr K S Krishnan Rd New Dehli 110012 INDIA</p>

M8	<p data-bbox="288 304 379 333">NIMT</p> <p data-bbox="236 412 432 441">(THAILAND)</p>	<p data-bbox="587 248 1158 277">Contact Person: Mrs Ajchara Charoensook</p> <p data-bbox="699 304 1066 333">E-mail: ajchara@nimt.or.th</p> <p data-bbox="536 356 1018 385">Telephone Number: +66 2 248 2181</p> <p data-bbox="619 412 1018 441">Fax Number: +66 2 248 4485</p> <p data-bbox="564 463 1458 492">Delivery Address: National Institute of Metrology Thailand (NIMT)</p> <p data-bbox="815 519 1278 548">Department of Electrical Metrology</p> <p data-bbox="815 571 1286 600">Ministry of Science and Technology</p> <p data-bbox="815 622 1075 651">75/7 Rama VI Road</p> <p data-bbox="815 674 1150 703">Thungphayathai, Rajthevi</p> <p data-bbox="815 725 1023 754">Bangkok 10400</p> <p data-bbox="815 777 983 806">THAILAND</p>
-----------	---	--

M9	<p data-bbox="248 999 419 1028">NML, CSIR</p> <p data-bbox="197 1106 469 1135">(SOUTH AFRICA)</p>	<p data-bbox="587 943 1034 972">Contact Person: Mr Louis Marais</p> <p data-bbox="699 999 1098 1028">E-mail: ELMarais@csir.co.za</p> <p data-bbox="536 1050 1034 1079">Telephone Number: +27 12 841 3013</p> <p data-bbox="619 1106 1034 1135">Fax Number: +27 12 841 4458</p> <p data-bbox="564 1158 1410 1187">Delivery Address: National Metrology Laboratory (NML), CSIR</p> <p data-bbox="815 1214 911 1243">Build 5</p> <p data-bbox="815 1265 1310 1294">CSIR, National Metrology Laboratory</p> <p data-bbox="815 1317 1059 1346">Meiring Naude Rd</p> <p data-bbox="815 1368 963 1397">Brummeria</p> <p data-bbox="815 1420 916 1449">Pretoria</p> <p data-bbox="815 1471 879 1500">0001</p> <p data-bbox="815 1523 1050 1552">SOUTH AFRICA</p>
-----------	---	---

M11	<p data-bbox="284 1749 379 1778">SIRIM</p> <p data-bbox="236 1856 432 1886">(MALAYSIA)</p>	<p data-bbox="587 1693 1238 1722">Contact Person: Abdul Rashid Bin Zainal Abidin</p> <p data-bbox="699 1749 1214 1778">E-mail: abd.rashid_z.abidin@sirim.my</p> <p data-bbox="536 1800 1027 1830">Telephone Number: +603 8778 1600</p> <p data-bbox="619 1856 1027 1886">Fax Number: +603 8778 1616</p>
------------	--	---

	<p>Delivery Address: Standards & Industrial Research Institute of Malaysia (SIRIM) Berhad National Metrology Laboratory SIRIM Berhad PT Lot 4803 Bandar Baru Salak Tinggi 43900 Sepang Selangor Darul Ehsan MALAYSIA</p>
--	---

M12		<p>Contact Person: Mr Y K Yan E-mail: ykyan@itc.gov.hk Telephone Number: +852 2829 4855 Fax Number: +852 2824 1302 Delivery Address: Standards and Calibration Laboratory (SCL) 36/F., Immigration Tower 7 Gloucester Road Wanchai HONG KONG</p>
	<p>SCL (HONG KONG)</p>	

M13		<p>Contact Person: Mr R Hadi Sardjono E-mail: Sar_djono@yahoo.com Telephone Number: +62 21 756 0571 Fax Number: +62 21 756 0568 Delivery Address: Puslitbang KIM-LIPI Electrical Metrology Laboratory Kompleks PUSPIPTEK Serpong (15314) Tangerang, BANTEN INDONESIA</p>
	<p>KIM-LIPI (INDONESIA)</p>	

M14	MSL (NEW ZEALAND)	Contact Person: Dr Laurie Christian E-mail: L.Christian@irl.cri.nz Telephone Number: +64 4 931 3110 Fax Number: +64 4 931 3194 Delivery Address: Measurement Standards Laboratory(MSL), IRL Inwards Goods Store Industrial Research Ltd Gracefield Road Lower Hutt NEW ZEALAND
------------	--	--

M16	<p data-bbox="300 309 368 338">NIM</p> <p data-bbox="268 416 400 448">(CHINA)</p>	<p data-bbox="587 253 1038 284">Contact Person: Zhang Zhonghua</p> <p data-bbox="699 309 1102 340">E-mail: zzh@public.bta.net.cn</p> <p data-bbox="536 360 1126 392">Telephone Number: +86 10 6421 1631-3304</p> <p data-bbox="619 416 1050 448">Fax Number: +86 10 6421 8629</p> <p data-bbox="564 472 1310 656">Delivery Address: National Institute of Metrology (NIM) No. 18 BeiSanHuan Dong Lu Beijing 100013 CHINA</p>
------------	---	---

M18	<p data-bbox="284 846 384 875">VNIIM</p> <p data-bbox="220 954 448 1019">(RUSSIA FEDERATION)</p>	<p data-bbox="587 790 1070 822">Contact Person: Dr Yuri P Semenov</p> <p data-bbox="699 846 1134 878">E-mail: Y.P.Semenov@vniim.ru</p> <p data-bbox="536 898 1031 929">Telephone Number: +7 801 323 9621</p> <p data-bbox="619 969 1034 1001">Fax Number: +7 812 316 1030</p> <p data-bbox="564 1043 1469 1373">Delivery Address: D I Mendeleyev Institute for Metrology (VNIIM), Gosstandart of Russia ATTN: V Dyskin 19 Moskovsky pr. St. Petersburg 198005 RUSSIA FEDERATION</p>
------------	--	--

Appendix I: Schedule

Measurement Period	Laboratory	Economy	Receive Date	Ship Date	Report Date
M0	NMI	Australia		12 January, 2004	
M1	NMIJ	Japan	19 January, 2004	09 February, 2004	22 March, 2004
M2	KRISS	Korea	16 February, 2004	08 March, 2004	19 April, 2004
M3	PSB	Singapore	15 March, 2004	05 April, 2004	17 May, 2004
M4	CMS/ITRI	Chinese Taipei	12 April, 2004	03 May, 2004	14 June, 2004
M5	NMI	Australia	10 May, 2004	31 May, 2004	
M6	CPEM 2004: 27 June - 2 July				
M7	NPL	India	05 July, 2004	26 July, 2004	06 September, 2004
M8	NIMT	Thailand	02 August, 2004	23 August, 2004	04 October, 2004
M9	NML, CSIR	South Africa	30 August, 2004	20 September, 2004	01 November, 2004
M10	NMI	Australia	27 September, 2004	18 October, 2004	
M11	SIRIM	Malaysia	25 October, 2004	15 November, 2004	27 December, 2004
M12	HKGSCCL	Hong Kong	22 November, 2004	13 December, 2004	24 January, 2005
M13	LIPI	Indonesia	20 December, 2004	10 January, 2005	21 February, 2005
M14	IRL	New Zealand	17 January, 2005	07 February, 2005	21 March, 2005
M15	NMI	Australia	14 February, 2005	07 March, 2005	
M16	NIM	China	14 March, 2005	04 April, 2005	16 May, 2005
M17	Extra time for custom clearance to VNIIM				
M18	VNIIM	Russian Federation	09 May, 2005	30 May, 2005	11 July, 2005
M19	NMI	Australia	06 June, 2005		

Additional Schedule:

Measurement Period	Laboratory	Economy	Receive Date	Ship Date	Report Date
M20	NMI	Australia		20 January 2006	
M21	KRISS	Korea	27 January 2006	17 February 2006	31 March 2006
M22	SPRING	Singapore	24 February 2006	17 March 2006	28 April 2006
M23	NMIJ/AIST	Japan	24 March 2006	14 April 2006	26 May 2006
M24	CMS/ITRI	Chinese Taipei	21 April 2006	12 May 2006	23 June 2006
M25	NMI	Australia	19 May 2006		